

SuperEvac™ PLUS II Vacuum Pump

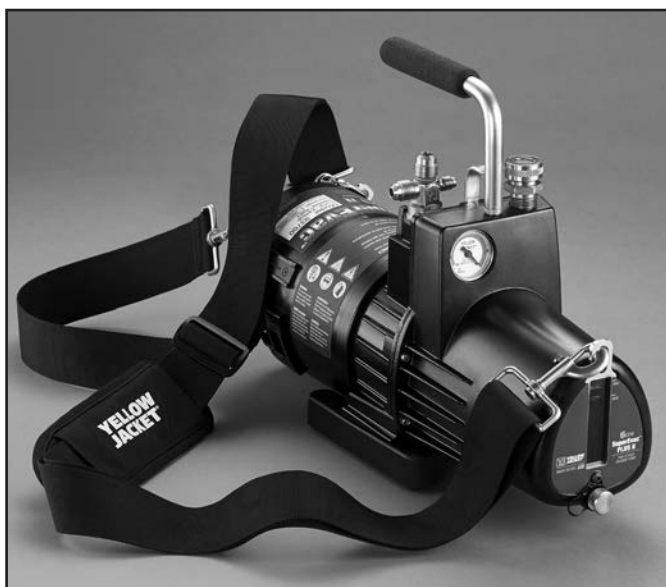

Operation and Maintenance Manual

Models: 9371x 9374x, 9376x, 9378x, 9379x

**Test Equipment
Depot**
1-800-517-8431

5 Commonwealth Ave
Woburn, MA 01801
Phone 781-665-1400
Toll Free 1-800-517-8431

PN #143060_RevB

Table of Contents

Page

Features of Your New Pump.....	3
The Purpose of the SuperEvac™ PLUS II Design.....	4
Important Steps of Initial Start-up.....	5
Vacuum Tips for Best Performance.....	5-6
Dual Voltage Motor Power Conversion.....	6
Basic Troubleshooting.....	7
• Four Most Common Problems	
• Oil Leakage	
• The Steps to Solving 95% of All Problems	
Diagnostic Chart.....	8, 9
Replacement Parts.....	10, 11
Warranty and Service.....	12

Important Notices to Purchaser

Check for damage immediately.

Prior to shipment, all YELLOW JACKET® SuperEvac™ PLUS II vacuum pumps are completely tested and inspected to assure compliance with Ritchie Engineering factory specifications.

If the pump carton is damaged, check contents immediately. Note damage on shipper's Bill of Lading and have shipper sign your statement. Notify the carrier immediately of the damage to arrange inspection of the pump and packaging.

The CARRIER ALONE is responsible for handling and settling your claim. Ritchie Engineering will cooperate in assessing damage if the pump is returned to the factory prepaid.

CARTON CONTENTS INCLUDE:

- SuperEvac™ PLUS II Pump
 - Bottle of YELLOW JACKET® SuperEvac™ Pump Oil
 - Shoulder Strap
 - Locking, Removable Power Cord
 - Owner's Manual
-

Warning

- This unit generates a deep vacuum that can be harmful to human tissue. Do not expose any part of the human body to the vacuum.
- Do not operate this unit with the exhaust blocked or restricted. Remove red shipping cap prior to use.
- Keep unit a minimum of 4" (10 cm) from objects to provide adequate cooling of motor.
- Continuous sound pressure level of this unit can exceed 70dB (A).
- Wear goggles and protective clothing when using this product.
- Designed for use with A2L systems.
- This unit is only rated as non-sparking. Not intended for use in Zone 0 or Zone 1 hazard areas.

Warranty is void if the set vacuum pump voltage does not match the power supply.

Features of Your New Pump

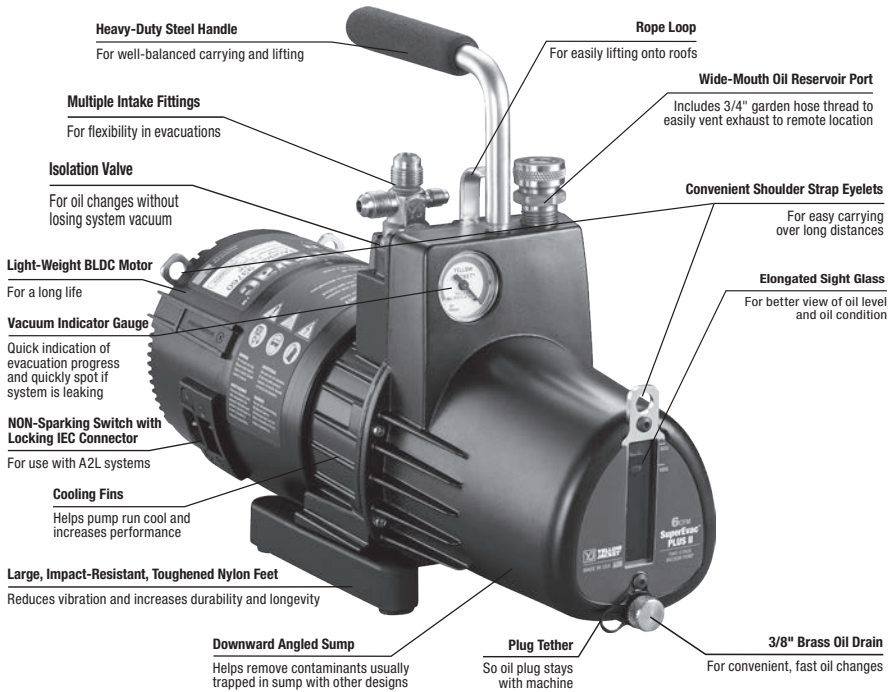

1. Male flare pump intake. Tethered cap stays with unit. Large diameter hose suggested for maximum pull down.
2. Additional intake ports.
3. Vacuum gauge shows evacuation progress down to 30" range, so you will know when to turn on electronic gauge for more precise reading.
4. Gas ballast valve (not shown) helps remove moisture and other condensable vapors that have been drawn into the pump as a result of evacuation.
5. Opening the ballast allows fresh air to enter the cartridge and keep vapors from combining with the oil. Vapors escape harmlessly through the exhaust valve. If combined with oil, vapors can turn the oil milky white and lower pump performance below specifications.
6. To operate ballast, turn the valve counter-clockwise one full turn after evacuation starts. As the vacuum reading reaches 1000-2000 microns, close the ballast to achieve a higher vacuum range.

Light weight universal BLDC motor can run on voltage as low as 85 volts with no issue, and draws fewer amps than AC motors.

The Purpose of the SuperEvac™ PLUS II Design

The SuperEvac™ PLUS II pump is a 2-stage rotary vane design (at right) that increases efficiency and speeds pump down to 15 microns.

The pump lowers the internal pressure of a refrigeration system until moisture boils into a vapor. As the moisture is vaporized, it is evacuated by the pump to help dehydrate the system. Most technicians try to achieve between 250 and 1000 microns.

A manometer or electronic vacuum gauge are the only ways to monitor evacuation progress. Manometer readings are approximate in inches of mercury. Only an electronic vacuum gauge (see page 8) is accurate enough to show when you reach the desired micron range.

As the chart shows, only an electronic vacuum gauge reads fine differences to provide assurance that the vacuum is low enough to boil the greatest possible amount of moisture.

Boiling Temp of Water	Inches Mercury	Microns
212°F (100°C)	0	760,000
151°F (66°C)	22.05	200,000
101°F (38°C)	27.95	50,000
78°F (26°C)	28.95	25,000
35°F (2°C)	29.72	5,000
1°F (17°C)	29.88	1,000
-50°F (-46°C)	29.92	50

How one small drop dampens your profits.

A small drop of moisture can hurt your profits and reputation.

During new system set-up, protective caps are removed admitting moisture and air into system components.

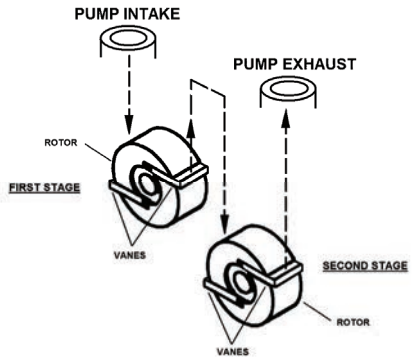

First stage exhausts into the intake of the second stage similar to two single stage pumps connected together.

If air – a non-condensable – remains in the system, it collects on the high side reducing system efficiency. This causes a rise in head pressure. The discharge valve gets hotter than normal and organic solids form causing compressor failure.

Moisture in the system can form ice which closes off openings in expansion valves and cap tubes, and prevent adequate cooling.

Ultimately moisture and air can produce acids and sludge which could cause in-warranty failures.

During service and parts replacement, the same contaminants get in again, and you could be called back for repairs by a dissatisfied customer.

Moisture and air can even enter through system leaks. And as the moisture in the air increases, so does the amount of contamination. The higher the humidity, the bigger your problem.

A vacuum pump “pulls” air and moisture out of the system before the system is damaged. The higher and more complete the vacuum, the more moisture is removed. That’s why your SuperEvac™ PLUS II pump is specifically engineered for high vacuums of 15 microns and better.

Important Steps of Initial Start-Up

1. Make sure motor is off and the voltage selector switch is set to the appropriate voltage.
2. Remove oil fill cap on pump cover. Fill with YELLOW JACKET® SuperEvac™ Pump Oil until oil level is even with oil level line.
3. Make sure blank-off valve is in the open position (vertical). **Stay clear of the oil fill/exhaust port!** Remove intake cap to open intake to the atmosphere and then switch on the motor. When pump reaches running speed, replace cap. The vacuum indicator gauge should read 30 inches.
4. To check the pump's performance, attach a micron gauge to the 1/4" male flare fitting, making sure that the intake fitting is capped and the gas ballast valve is closed. Turn on the pump. The micron gauge will display the ultimate vacuum reached.
5. Improve cold weather starting by opening intake and running your pump for 60 seconds...motor has cold weather soft-start mode and may take up to 60 seconds for temperatures 0c and below.
6. When turning pump off, open intake fitting until vacuum indicator gauge reads zero to break vacuum just **prior** to shut-off.
7. Disconnect pump and put cap on intake to keep out contaminants.
8. If an extension cord is needed, refer to the below chart for proper sizing.

RECOMMENDED EXTENSION CORD SIZES

Total Extension Cord Length (feet)		
25'	50'	100'
16 Ga.	14 Ga.	12 Ga.
Wire Gauge (AWG)		

Vacuum Tips for Best Performance

Quick Tips:

1. For the fastest vacuum, connect your pump directly to the system. Going through a manifold slows the job.
2. Use as **large** a hose as possible, even though the system has 1/4" fittings. A 1/2" or 3/8" hose allows a much faster and more complete vacuum.
3. Use as **short** a hose as practical to get maximum evacuation speed. Short hoses make evacuation faster than longer hoses. Long hoses slow the process.
4. **Metal hoses** are the most impervious so will be most effective in evacuation.
5. Evacuate through both **high and low** sides at the same time to speed evacuation.
6. Use the **4-in-1 Vacuum/Charge Valve & Core Tool (Part #18975)** to remove the Schrader valves from the system and evacuate through unrestricted lines for a faster and higher vacuum. Removing Schraders saves over 30% in time.
7. Use **two pumps** on very large systems to reduce vacuum time. Put one of the pumps on the low side of the system and one pump on the high side of the system.



8. Use a SuperEvac System I, II or III to decrease vacuum time by over 50%.

These systems include a 2-valve vacuum manifold and two 3/8" vacuum hoses which can evacuate three times faster than a 1/4" hose.



9. Use a heat gun on the condenser and evaporator to speed the evacuation process.

Built-in Vacuum Gauge:

The built-in indicator gauge in your pump monitors evacuation progress down to the 29-30" range. If the reading stays in the mid range, there is either high contamination or a large leak in the system.



Gross Leak

If you think there is excessive moisture, blow out the AC&R system with dry nitrogen wherever possible. This reduces the amount of contaminants that must be "pulled" into the pump and increases evacuation speed.

Use a nitrogen regulator valve with pressure limited to 150 psi and a frangible disc device set at 175 PSIG.



Turn on Electronic Gauge

When the indicator reaches the 29-30" range, turn on the electronic micron gauge for more precise readings.

Oil Changes: CHANGE OIL AFTER EACH USAGE to protect pump components from contaminants pulled into pump during service. Place used oil in a sealable container and dispose properly in accordance with local regulations.

Dual Voltage Motor Power Conversion (if applicable)

STEP 1

Disconnect power from motor. Unscrew voltage switch cover.



STEP 3

Replace cover and screw down by hand. Do not use drill as cover could crack.



STEP 2

Remove cover, use screwdriver to switch to appropriate voltage setting.

115=100-120vac
50/60 hz

230=230-240 vac
50/60 hz



CAUTION

- Always remove cord before changing voltage.
- Incorrect voltage setting can result in destruction of controller electronics, rendering motor inoperable.
- To maintain IP X2 rating, replace switch cover to keep water out of controller.
- Over-tightening screw could result in cracked cover.

Warranty is void if the set vacuum pump voltage does not match the power supply.

Basic Troubleshooting

Four Most Common Comments on Pump Return Paperwork:

1. **“Will not pump.”** This usually means the pump will not pull a high enough vacuum. This can be caused by valve being left open, missing O-rings under caps or contaminated oil.

SUGGESTION: Change valve and O-rings change oil twice and recheck vacuum.

2. **“Will not pull below 1000 microns.”**

SUGGESTION: Check for O-rings. Test pump to determine actual pull down. Remove all hoses and connect vacuum sensor directly to pump.

3. **“Noisy.”** Pumps are noisy when they have not achieved a high vacuum. In intermediate vacuum, there will be oil, vane and exhaust noises.

SUGGESTION: Listen to the pump at high vacuum. If relatively quiet, the pump is running properly. If still noisy, there may be a system leak.

4. **“Repair and return.”** This is the most difficult return comment to handle, since we are unsure of what needs to be done to keep the customer satisfied.

SUGGESTION: Be specific about the problem with your pump if returning it.

Starting Problems

- Be sure pump is plugged into live receptacle with line voltage plus or minus 10% of voltage on motor nameplate. Long extension cords can greatly reduce voltage and cause problems.
- Pump/oil temp. must be 30°F (-1°C) or higher. Open intake to atmosphere and switch on pump; run up to speed before connecting to system.

- Your SuperEvac™ PLUS II pump features a heavy-duty high torque motor for cold weather starting, but dirty oil makes starting more difficult, causing unnecessary wear on your unit.
- Dropping your pump can damage it. In a locked pump condition, motor will not run and the thermal overload will kick out.
- Disconnect power cord and set pump with front cover face down on table. Reach into coupling area and try to rotate the coupling. Do not use pliers. If the pump does not rotate, it is "locked up."

Oil Leakage

- If leak develops between front and rear half of oil case, tighten all screws. Replace gasket if necessary.
- If shaft seal leaks, replace it.
- Wipe pump dry and watch for source of leak. Tighten screws and repair.

The Steps to Solving 95% of All Problems

1. **Check oil level when pump is running.** It should be between the indicated levels.
2. **Check vacuum pump.** Connect micron gauge directly to the 1/4" port and cap intake port. Turn on pump, open the valve and check vacuum reading. If reading is good, check the system for leaks. OR, if testing a system, isolate pump with blank-off valve and get vacuum reading from the pump alone. If the pump does not pull and stay at a poor vacuum level, run until hot and change oil.
3. **Check all flare connections.** Make sure they are tight.

SuperEvac™ Digital Vacuum Gauges



The YELLOW JACKET® OMNI™ Digital Vacuum Gauge is an easy-to-use, compact vacuum gauge that is loaded with features for the price. Easily set target vacuum level and the OMNI™ will give audio and visual signals when that level is reached. The easy-to-clean vacuum sensor handles 450 psi positive pressure and reads several units of vacuum (microns, millibar, Torr, and Pascal) (**Part #69020**).



The SuperEvac™ LCD Vacuum Gauge is a portable, lightweight, solid state instrument that indicates the vacuum pressure in the system using thermocouple technology. This is important because you need to know the vacuum to confirm moisture removal. The battery powered gauge measures atmospheric pressures of 760,000 to 1 micron in easy to read 1/2" high numbers (**Part #69075**).

Diagnostics Chart

Condition	Pump Area	Possible Problem	Solution
Poor Vacuum	Quiet Pump	Dirty oil Drive coupling or set screw loose Bent or broken exhaust valve Pump not oiling Vaness not functioning	Flush 1 to 3 times Repair or replace Repair or replace Call factory Call factory
	Ultimate of pump does not meet mfg. spec (when read with thermocouple gauge)	Pump dropped Micron gauge malfunction Poor motor performance Dirty oil Air leaks System leaks Fitting sealant compound	Call factory Verify with second gauge Repair or replace Flush 1 to 3 times Repair or replace Isolate/repair Repair or replace
Oil Leaks	Exhaust	Oil level high System vented pressure through pump Pump tipped over	Adjust oil level Check oil level, add or replace oil Check oil level, add or replace oil
	Seal	Worn or damaged seal Motor loose	Replace Adjust/tighten, check seal
	Case	Gasket bolts loose Oil drain fitting Gasket damaged	Tighten Repair or replace Replace

Diagnosics Chart continued

Condition	Pump Area	Possible Problem	Solution
Pump Won't Start	Motor Stalled hot/cold	Damaged motor Damaged pump Closed intake/gas ballast on pumps	Repair or replace Replace/call factory Open intake fitting and gas ballast
	Ultimate of pump does not meet mfg. spec (when read with thermocouple gauge)	Low voltage Cold weather cut-out Dirty Oil	Shorter extension cord Open intake fitting for 10-15 sec. to warm up while starting Flush 1 to 3 times
Unusually Noisy	Motor Areas	Worn motor Loose motor bolts Drive coupling	Replace motor Tighten bolts Adjust/replace coupling
	Pump Cartridge	Dirt, low, improper oil Air leaks: 1. Caps/connections 2. Gaskets/O-rings 3. Fittings 4. System leak	Flush and replace oil Tighten Replace/put on oil Replace/reseal Isolate pump with blank-off valve and repair system leak
High Temp.	Motor	Low voltage	Short extension cord
	Pump	Dirty oil Low oil Lint/foreign material Parts friction Too small for system Air leaks	Flush and replace Add/replace Open gas ballast Replace oil/call factory Size pump for system Replace/repair
Poor Vacuum	Noisy Pump	System leaks Low oil level Dirty oil Worn pump Air leaks and fittings or gasket seals	Repair leaks Add/replace Flush 1 to 3 times Replace module, call factory Replace/repair

Replacement Parts

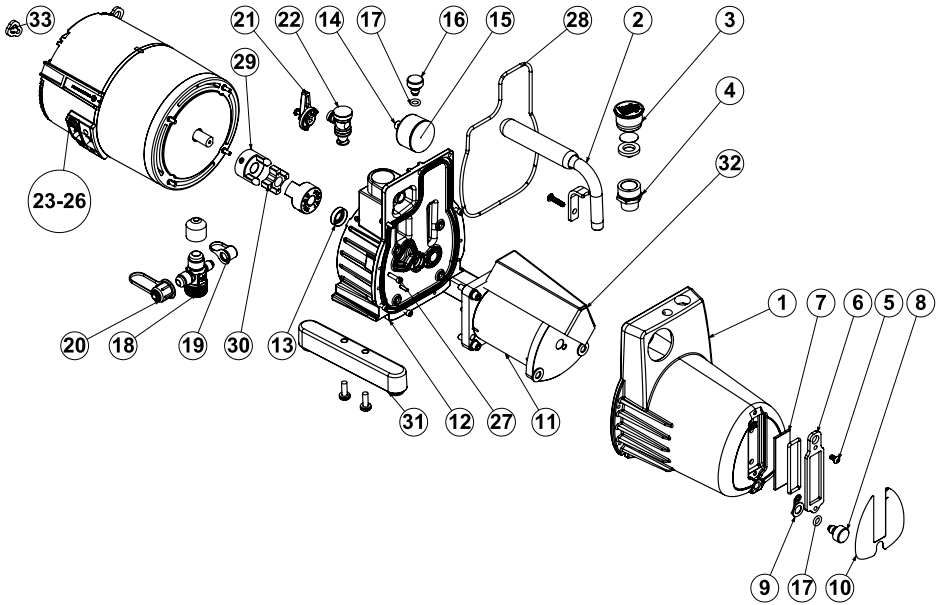

	PUMP # 93714 93716 93794 9374x	PUMP # 93715 93796 9376x	PUMP # 93711 9378x	PUMP # 93790 93792 93795 93798
	4 CFM	6 CFM	8 CFM	11 CFM
	(113 L/M)	(170 L/M)	(227 L/M)	(311 L/M)
Pump Cover				
1. Complete cover (individual parts listed below)	92736	92737	92738	92739
2. Handle with screw	92741	92741	92741	92741
3. Oil fill cap and seal	93390	93390	93390	93390
4. Oil fill fitting	93391	93391	93391	93391
5. Pair of sight glass screws	92933	92933	92933	92933
6. Sight glass bezel	92934	92934	92934	92934
7. Sight glass and gasket	92935	92935	92935	92935
8. Oil drain plug	92952	92952	92952	92952
9. Tether	92932	92932	92932	92932
10. Cover label	92744	92745	92746	92747
Vacuum Cartridge				
11. Complete cartridge with oil cover gasket	92948	92949	92950	92951

	PUMP # 93714 93716 93794 9374x	PUMP # 93715 93796 9376x	PUMP # 93711 9378x	PUMP # 93790 93792 93795 93798
	4 CFM	6 CFM	8 CFM	11 CFM
	(113 L/M)	(170 L/M)	(227 L/M)	(311 L/M)
Mount Body				
12. Complete mount body	92753	92753	92754	92754
13. Shaft seal	93031	93031	93031	93031
14. 30" vacuum gauge	93011	93011	93011	93011
15. Vacuum gauge crystal	93012	93012	93012	93012
16. Gas ballast with "O"-ring	93368	93368	93368	93368
17. "O"-ring for gas ballast/drain plug	93398	93398	93398	93398
18. Intake fittings	92930 (3/8")	92930 (3/8")	92931 (1/2")	92931 (1/2")
19. Intake cap (1/4")	93394	93394	93394	93394
20. Intake caps	93399 (3/8") 40284 (Acme)	93399 (3/8") 40284 (Acme)	93395 (1/2") 40284 (Acme)	93395 (1/2") 40284 (Acme)
21. Blank-off valve handle & screw only	93366	93366	93366	93366
22. Complete parts for blank-off	93367	93367	93367	93367
Motor				
23) SuperEvac Universal Motor	93713	93713	93713	93713
24) Locking IEC to NEMA 5-15	92755	92755	92755	92755
25) Locking IEC to UK	92757	92757	92757	92757
26) Locking IEC to EU	92756	92756	92756	92756
26a) Locking IEC to AU/NZ	92758	92758	92758	92758
Final Assembly Parts				
27. 8/32 x 5/8" socket head cap screw	93506	93506	93506	93506
28. Oil cover gasket	92942	92942	92942	92942
29. Drive coupling	93047	93047	93047	93047
30. Coupling spider	93050	93050	93050	93050
31. Right or left leg assembly	92959	92959	92959	92959
32. Cartridge baffle	92940	92940	92940	92940
33. Shoulder strap mount	92943	92943	92943	92943

Damaged supply cords must be replaced by special assemblies available from the manufacturer or its distributors

Vacuum Pump Weights

9374x	9376x	9378x	9379x
24.6 lbs. (11.2 kg)	25.9 lbs. (11.7 kg)	26.8 lbs. (12.2 kg)	28.4 lbs. (12.9 kg)

WARRANTY INFORMATION

Ritchie Engineering guarantees YELLOW JACKET® products to be free of defective material and workmanship which could affect the life of the product when used for the purpose for which it was designed. This warranty does not cover items that have been altered, abused (including failure to use the correct type of vacuum pump oil) or returned solely in need of field service maintenance.

If found defective, we will either replace or repair at our option products within warranty period. Returns must be prepaid.

Warranty does not cover use of lithium bromide, ammonia or leak stop type products.

Warranty is void if the set vacuum pump voltage does not match the power supply.

How to Obtain Service

Most returned pumps are merely in need of normal field service maintenance, such as changing oil or making minor adjustments. In many instances, the troubleshooting information in this manual can save you the time and effort of returning your pump. When the information contained in this manual, however, does not solve the problem, please call for service.

