

MR6000

MR6000-01



99 Washington Street
Melrose, MA 02176
Phone 781-665-1400
Toll Free 1-800-517-8431

Visit us at www.TestEquipmentDepot.com

MEMORY HiCORDER

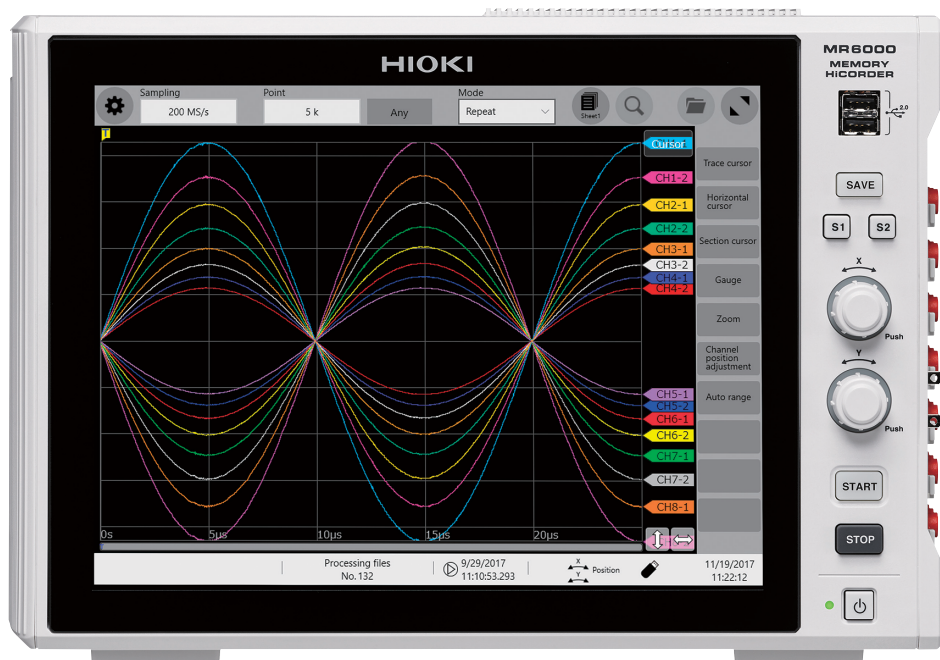

! Be sure to read this manual before using the instrument. ▶ p. 6

- ✓ When using the instrument for the first time**
- Name and Function of Each Part ▶ p. 20
 - Basic Operation ▶ p. 27
 - Preparing for Measurement ▶ p. 37

- 📖 Troubleshooting**
- Maintenance and Service ▶ p. 135
 - Troubleshooting ▶ p. 137
 - Message ▶ p. 140

FAQ



To set the measurement range automatically

Refer to “3.7 Measuring Signals With the Auto-range Setting” (p. 81).



To change the measurement range

Refer to “Analog channel” (p. 73).



To add a comment to the data

Refer to “Touch keyboard” (p. 34) and “Analog channel” (p. 73).



To minimize influence of noise (Low-pass filter, LPF)

Refer to “Analog channel” (p. 73).



To change the sampling rate

Refer to “3.2 Setting Measurement Conditions” (p. 70).



To configure the trigger settings

Refer to “3.4 Configuring the Level Trigger Settings” (p. 75).



To scroll through the waveform display

Refer to “4.2 Handling Waveforms” (p. 86).



To read measured values (cursor values) with cursors

Refer to “4.1 Reading Measured Values (Trace Cursors)” (p. 83).



To save data files

Refer to “3.6 Saving Data Consisting of Items Selected” (p. 78).



To estimate file size

Refer to “14.1 Information for Reference Purposes” of Instruction Manual.



To open data files with your computer

Refer to “4.3 Loading Data on Your Computer (Wave Viewer)” (p. 87).

Measurement Procedure

The basic measurement procedure is as follows. For advanced use, refer to Instruction Manual (PDF) in the accompanying CD.

Preparing for measurement (p. 37)

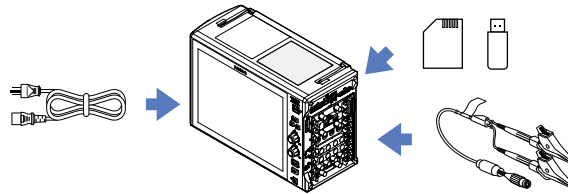

Inspecting the instrument before measurement (p. 69)

Configuring the basic settings for measurement (p. 70)

- Choose a sampling rate.
- Choose a recording length (shot).

Configuring the input channel settings (p. 72)

- Configure the analog channel settings.

Configuring the trigger settings (p. 75)

- Configure the trigger settings.

Starting/Stopping measurement (p. 77)

Saving waveform data files (p. 78)



Analyzing waveforms (p. 83)

- Scroll through, zoom in, and zoom out waveforms.
- Read measured values (with the trace cursors).

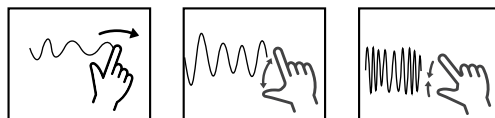

Finishing the measurement

Contents

Introduction.....	1
Notations.....	2
Confirming Package Contents.....	4
Options (sold separately).....	5
Safety Information.....	6
Operation Precautions.....	8
How to Refer to This Document.....	17

1 Overview 19

1.1 Product Overview and Features.....	19
1.2 Name and Function of Each Part.....	20
1.3 Screen.....	24
Screen configuration.....	24
Explanation of each screen.....	25
1.4 Basic Operation.....	27
Touch panel.....	27
Rotary knob.....	28
Changing screens and settings.....	30
Quick-access menu.....	32
Key lock.....	33
Help function (Displaying manuals).....	33
Mouse operation.....	34
Touch keyboard.....	34

2 Preparing for Measurement 37

2.1 Installing and Removing Modules.....	38
Allocation of modules and channels.....	39
2.2 Attaching Connection Cords.....	40
Connection cords (For measuring voltage, frequency, or rotation speed, and obtaining accumulations).....	41
Thermocouple (Temperature).....	43
Strain gauge transducer.....	44
Current sensor.....	46
Acceleration sensor.....	49
Logic probe (Measuring logic signals).....	51
Connection cable (For precisely measuring voltage).....	51
Connection cable (for measuring high voltage).....	52
2.3 Supplying Power to Current Sensors.....	53
2.4 External Sampling (EXT.SMPL).....	54
2.5 Connecting the External Control Terminals.....	55
2.6 Connecting the Instrument With Computers.....	57
2.7 Preparing Storage Devices (Recording Media).....	59
SD memory card.....	59
USB flash drive.....	59

Built-in drive.....	60
Removing storage devices.....	60
Formatting storage devices.....	61
2.8 How to Open the Media Box.....	62
2.9 Supplying Power to the Instrument.....	63
Turning on the instrument.....	63
GND terminal (functional earth terminal).....	63
Turning off the instrument.....	63
2.10 Setting the Clock.....	64
2.11 Executing Zero-Adjustment.....	65
2.12 Executing Calibration (For the Instrument With Model MR8990 Installed).....	67

3 Measurement Method 69

3.1 Inspection Before Measurement.....	69
3.2 Setting Measurement Conditions.....	70
Sampling rate setting guideline.....	71
3.3 Configuring the Input Channel settings.....	72
Analog channel.....	73
3.4 Configuring the Level Trigger Settings.....	75
3.5 Starting/Stopping a Measurement.....	77
3.6 Saving Data Consisting of Items Selected.....	78
Save types and setting procedure.....	78
Selective save.....	79
3.7 Measuring Signals With the Auto-range Setting.....	81

4 Analysis Method 83

4.1 Reading Measured Values (Trace Cursors).....	83
4.2 Handling Waveforms.....	86
Scrolling through waveforms.....	86
Zooming in and out waveforms.....	86
4.3 Loading Data on Your Computer (Wave Viewer).....	87

5 Specifications 89

5.1 Specifications of Model MR6000.....	89
General specifications.....	89
Trigger.....	93
Waveform screen.....	95
Setting screen.....	96
File.....	99
Calculation.....	100
Memory division.....	103
Waveform search.....	103

1

2

3

4

5

6

Index

	Others	103
5.2	Specifications of the Options	105
	Model Z5021 Probe Power Unit.....	105
	Model U8332 SSD Unit.....	105
	Model U8333 HD Unit.....	106
	Model 8966 Analog Unit.....	106
	Model 8967 Temp Unit.....	108
	Model 8968 High Resolution Unit.....	110
	Model U8969 Strain Unit.....	112
	Model 8970 Freq Unit.....	114
	Model 8971 Current Unit.....	116
	Model 8972 DC/RMS Unit.....	118
	Model 8973 Logic Unit.....	120
	Model MR8990 Digital Voltmeter Unit.....	120
	Model U8974 High Voltage Unit.....	122
	Model U8975 4ch Analog Unit.....	124
	Model U8976 High Speed Analog Unit.....	126
	Model U8977 3CH Current Unit (available for the firmware version 2.10 or later).....	128
	Model U8978 4CH Analog Unit (available for the firmware version 2.10 or later).....	130
	Model U8979 Charge Unit (available for the firmware version 2.10 or later).....	132

6 Maintenance and Service 135

6.1	Troubleshooting.....	137
	Before sending the instrument for repair.....	137
6.2	Initializing the Instrument.....	139
6.3	Message	140
	Error messages	141
	Warning messages	142
6.4	Self-check.....	146
	Memory check.....	146
	Touch panel check.....	147
	Key check.....	147
	LCD check.....	147
	LAN check.....	148
	Media check	149
	System configuration check.....	150
6.5	Cleaning the Instrument	150
6.6	Disposing of the Instrument (Removing the lithium battery).....	151

Index 153

Warranty

Introduction

Thank you for choosing the Hioki MR6000, MR6000-01 Memory HiCorder. Preserve this manual carefully and keep it handy to make full use of this instrument for a long time.

Model MR6000-01 Memory HiCorder is an upper model of Model MR6000, which is equipped with the following calculation functions (options):

- Digital filter calculation
- Real-time waveform calculation

Following manuals are provided along with these models. Refer to manuals relevant to your purpose.

Type	Contents	Printed	CD-stored File name
Operating Precautions	Information on the instrument for safe operation	✓	–
Quick Start Manual (This document)	Basic instructions and specifications of the instrument	✓	✓ MR6000A965-XX.pdf
Instruction Manual	Functions and instructions for the instrument	–	✓ MR6000A966-XX.pdf
MR6000-01 Dedicated Functions	Method to use functions including the calculation available only with Model MR6000-01	–	✓ MR6000A968-XX.pdf

Target audience

This manual has been written for use by individuals who use the product in question or who teach others to do so.

It is assumed that the reader possesses basic electrical knowledge (equivalent to that of someone who graduated from the electrical program at a technical high school).

Trademarks

- Microsoft and Internet Explorer are either registered trademarks or trademarks of Microsoft Corporation in the United States and other countries.
- The SD logo is a trademark of SD-3C, LLC.









- Any other products and company names are generally either trade names, registered trademarks or trademarks of respective companies.





Notations

Safety notations



In this document, the risk seriousness and the hazard levels are classified as follows.

 DANGER	Indicates an imminently hazardous situation that will result in death or serious injury to the operator.
 WARNING	Indicates a potentially hazardous situation that may result in death or serious injury to the operator.
 CAUTION	Indicates a potentially hazardous situation that may result in minor or moderate injury to the operator or damage to the instrument or malfunction.
IMPORTANT	Indicates information related to the operation of the instrument or maintenance tasks with which the operators must be fully familiar.
	Indicates a high voltage hazard. If a particular safety check is not performed or the instrument is mishandled, this may give rise to a hazardous situation; the operator may receive an electric shock, may get burnt or may even be fatally injured.
	Indicates prohibited action.
	Indicates the action which must be performed.

Symbols affixed to the instrument

	Indicates cautions and hazards. When the symbol is printed on the instrument, refer to "Operation Precautions" (p. 8) in this document and accompanying "Operating Precautions."
	Indicates the power button that switches the instrument between on and off states.
	Indicates a grounding terminal.
	Indicates DC (Direct Current).
	Indicates AC (Alternating Current).

Symbols for Standards

	Indicates the Waste Electrical and Electronic Equipment Directive (WEEE Directive) in EU member states.
	Indicates that the product conforms to regulations set out by the EU Directive.

Others

*	Additional information is presented below.
☑	Indicates the initial setting values of the items. Initializing the instrument restores settings to each of these values.
(p.)	Indicates the location of reference information.
START (Bold-faced)	Names and keys on the screen are indicated in boldface.
[]	Menus, dialog boxes, buttons in a dialog box, and other names on the screen are indicated in brackets.
Windows	Unless otherwise specified, "Windows" represents Windows 7, Windows 8, and Windows 10.
Current sensor	Sensors measuring current are referred to as "current sensor."
S/s	The number of times per second the analog input signals are digitized by the instrument is represented in "samples per second (S/s)." Example: "20 MS/s" (20 megasamples per second) indicates that the signal is digitized 20×10^6 times per second.

Accuracy

We define measurement tolerances in terms of f.s. (full scale) and rdg. (reading) values, with the following meanings:

f.s.	(maximum display value or scale length) The maximum displayable value or scale length.
rdg.	(displayed value) The value currently being measured and displayed on the measuring instrument.

Confirming Package Contents

When you open the package, inspect the instrument carefully to ensure that everything is in good condition, and that no damage occurred during shipping. Carefully check the accessories, panel keys and switches, and connectors. If the instrument seems to have been damaged or does not work as specified, contact your authorized Hioki distributor or reseller. Check that the package contents are correct.

Instrument

- Model MR6000 Memory HiCorder / Model MR6000-01 Memory HiCorder

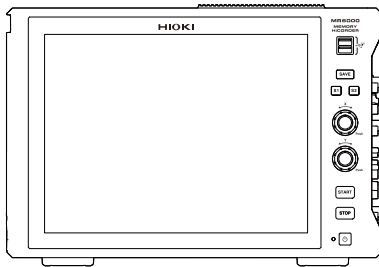

Accessories

- Power cord

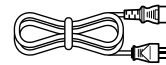

(p. 63)

- Operating Precautions (0990A903)



- Quick Start Manual (This document)



- Instruction Manual CD*¹
 - Quick Start Manual MR6000A965-XX.pdf
 - Instruction Manual MR6000A966-XX.pdf
 - MR6000-01 Dedicated Functions MR6000A968-XX.pdf

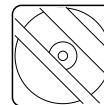

(p. 33)

- Application disc*¹

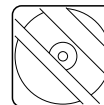

(p. 87)

- Blank panel (for slots with no module installed)



(p. 38)

*1: The latest version can be downloaded from our website.

Options (sold separately)

Options available only at the time of purchase order issuance for the instrument

Model U8332	SSD Unit
Model U8333	HD Unit
Model Z5021	Probe Power Unit

Input modules

Model 8966	Analog Unit
Model 8967	Temp Unit
Model 8968	High Resolution Unit
Model U8969	Strain Unit
Model 8970	Freq Unit
Model 8971	Current Unit
Model 8972	DC/RMS Unit
Model 8973	Logic Unit
Model U8974	High Voltage Unit
Model U8975	4ch Analog Unit
Model U8976	High Speed Analog Unit
Model MR8990	Digital Voltmeter Unit
Model U8977	3CH Current Unit
Model U8978	4CH Analog Unit
Model U8979	Charge Unit

Carrying case

Model C1010	Carrying Case
-------------	---------------

Software

Model 9335	Wave Processor
------------	----------------

SD memory cards

Model Z4001	SD Memory Card (2 GB)
Model Z4003	SD Memory Card (8 GB)

USB flash drive

Model Z4006	USB Drive (16 GB)
-------------	-------------------

Logic probes

Model 9320-01	Logic Probe
Model MR9321-01	Logic Probe
Model 9327	Logic Probe

LAN cable

Model 9642	LAN Cable
------------	-----------

For external sampling measurement

Model L9795-01	Connection Cable
Model L9795-02	Connection Cable

For voltage measurement

Model L9197	Connection Cord
Model L9198	Connection Cord
Model L9790	Connection Cord
Model L9217	Connection Cord
Model 9665	10:1 Probe
Model 9666	100:1 Probe
Model 9322	Differential Probe
Model P9000-01	Differential Probe
Model P9000-02	Differential Probe

For current measurement

Model CT6700	Current Probe
Model CT6701	Current Probe
Model 3273-50	Clamp on Probe
Model 3274	Clamp on Probe
Model 3275	Clamp on Probe
Model 3276	Clamp on Probe
Model 9709	AC/DC Current Sensor
Model 9709-05	AC/DC Current Sensor
Model 9272-05	Clamp on Sensor
Model 9272-10	Clamp on Sensor
Model CT6841	AC/DC Current Probe
Model CT6841-05	AC/DC Current Probe
Model CT6843	AC/DC Current Probe
Model CT6843-05	AC/DC Current Probe
Model CT6844	AC/DC Current Probe
Model CT6844-05	AC/DC Current Probe
Model CT6845	AC/DC Current Probe
Model CT6845-05	AC/DC Current Probe
Model CT6846	AC/DC Current Probe
Model CT6846-05	AC/DC Current Probe
Model CT6862	AC/DC Current Sensor
Model CT6862-05	AC/DC Current Sensor
Model CT6863	AC/DC Current Sensor
Model CT6863-05	AC/DC Current Sensor
Model CT6865	AC/DC Current Sensor
Model CT6865-05	AC/DC Current Sensor
Model CT6875	AC/DC Current Sensor
Model CT6876	AC/DC Current Sensor
Model CT7631	AC/DC Current Sensor
Model CT7636	AC/DC Current Sensor
Model CT7642	AC/DC Current Sensor
Model CT7731	AC/DC Auto-Zero Current Sensor
Model CT7736	AC/DC Auto-Zero Current Sensor
Model CT7742	AC/DC Auto-Zero Current Sensor
Model CT7044	AC Flexible Current Sensor
Model CT7045	AC Flexible Current Sensor
Model CT7046	AC Flexible Current Sensor
Model CT9900	Conversion Cable
Model CT9920	Conversion Cable

Safety Information

This instrument is designed to conform to IEC 61010 Safety Standards, and has been thoroughly tested for safety prior to shipment. However, using the instrument in a way not described in this manual may negate the provided safety features.

Read the following safety notes carefully before using the instrument.

DANGER



Mishandling the instrument could result in bodily injury or even death, as well as damage to the instrument. Familiarize yourself with the instructions and precautions in this manual before using the instrument.

WARNING



Electricity can cause potentially serious events such as an electric shock, heat generation, fire, and an arc flash due to a short-circuit. If you have not used electrical measuring instruments before, you should be supervised by a technician who has experience in electrical measurement.

Protective gear

WARNING



This instrument is measured on a live line. To prevent an electric shock, use appropriate protective insulation and adhere to applicable laws and regulations.

Measurement categories

To ensure safe operation of measuring instruments, IEC 61010 establishes safety standards for various electrical environments, categorized as CAT II to CAT IV, and called measurement categories.

DANGER



- Using a measuring instrument in an environment designated with a higher-numbered category than that for which the instrument is rated could result in a severe accident, and must be carefully avoided.
- Never use a measuring instrument that lacks category labeling in a CAT II to CAT IV measurement environment. Doing so could result in a serious accident.

CAT II: When directly measuring the electrical outlet receptacles of the primary electrical circuits in equipment connected to an AC electrical outlet by a power cord (portable tools, household appliances, etc.).

CAT III: When measuring the primary electrical circuits of heavy equipment (fixed installations) connected directly to the distribution panel, and feeders from the distribution panel to outlets.

CAT IV: When measuring the circuit from the service drop to the service entrance, and to the power meter and primary overcurrent protection device (distribution panel).

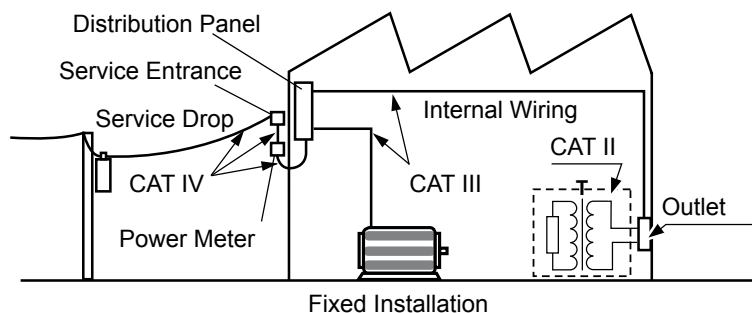

The applicable measurement category is determined based on the module being used. Refer to "Handling the instrument and modules" (p. 10).

Operation Precautions

Follow these precautions to ensure safe operation and to obtain the full benefits of the various functions.

Ensure that your use of the instrument falls within the specifications not only of the instrument itself, but also of any accessories, options and other equipment being used.

Checks before use

DANGER

If the connection cords or the instrument is damaged, there is a risk of an electric shock. Perform the following inspection before using the instrument:

- Check that the insulation of the connection cords are neither ripped nor torn and that no metal parts are exposed before using the instrument. Using the instrument under such conditions could result in an electric shock. Replace the connection cords with those specified by our company.
- Check if there is any damage to the instrument occurred during storage or shipping and verify that it operates normally before using the instrument. If you find any damage, contact your authorized Hioki distributor or reseller.



Installing the instrument and modules

WARNING

Installing the instrument in inappropriate locations could cause a malfunction of the instrument an accident, or fire. Avoid the locations that are:



- Exposed to direct sunlight or high temperatures
- Exposed to corrosive or combustible gases
- Exposed to strong electromagnetic fields or electrostatic charges
- Near induction heating systems (such as high-frequency induction heating systems and IH cooking equipment)
- Susceptible to vibration
- Exposed to water, oil, chemicals, or solvents
- Exposed to high humidity or condensation
- Exposed to high quantities of dust particles



Unplugging the power cord kills power to the instrument. Be sure to provide enough unobstructed space to unplug the power cord immediately in an emergency.

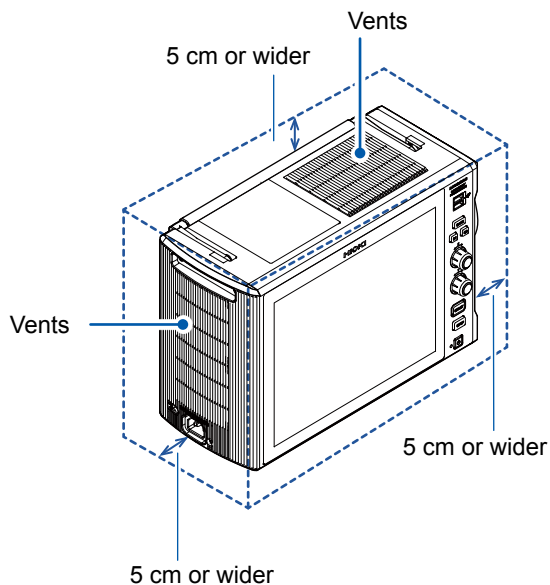

- Do not place the instrument on an unstable table.
- Do not place the instrument on an inclined surface.
- Do not stack the multiple instruments.
- Vents must not be obstructed.



- To prevent overheating, be sure to leave 5 cm (2 inches) around the instrument.
- The instrument should be operated only with the bottom or rear side downwards.

Power supply

CAUTION



To avoid damage to the instrument, do not unplug the power cord from the instrument when operations are in progress. Be sure to use the power key to turn off the instrument.

Handling the instrument and modules

⚠ DANGER



- Do not use the modules or the cords to measure circuits that exceed those ratings or specifications. Damage to the instrument or overheating can cause bodily injury.
- The maximum input voltage and maximum rated voltage to earth of the modules and connection cords are shown in the following table. To avoid an electric shock and damage to the instrument, ensure that input voltage never exceeds these limits. The lower maximum input voltage of the module or connection cord must be used. Measuring a voltage exceeding this value can cause damage to the instrument, resulting in bodily injury. The same applies to the maximum rated voltage to earth using an input attenuator for the measurement. Ensure that the connection does not allow the input voltage to exceed the maximum rated voltage to earth.
Refer to “5.2 Specifications of the Options” (p. 105).

Ratings of modules

Modules	Maximum input voltage	Maximum rated voltage to earth
Model 8966 Analog Unit	400 V DC	300 V AC/DC (CAT II)
Model 8967 Temp Unit	–	300 V AC/DC (CAT II)
Model 8968 High Resolution Unit	400 V DC	300 V AC/DC (CAT II)
Model U8969 Strain Unit	–	30 V rms / 60 V DC
Model 8970 Freq Unit	400 V DC	300 V AC/DC (CAT II)
Model 8971 Current Unit	–	Non-isolated
Model 8972 DC/RMS Unit	400 V DC	300 V AC/DC (CAT II)
Model 8973 Logic Unit	–	Non-isolated
Model U8974 High Voltage Unit	1000 V DC 700 V AC	1000 V AC/DC (CAT III) 600 V AC/DC (CAT IV)
Model U8975 4ch Analog Unit	200 V DC	300 V AC/DC (CAT II)
Model U8976 High Speed Analog Unit	400 V DC (Direct input) 1000 V DC (with Model 9665 10:1 Probe used)	1000 V AC/DC (CAT II)
Model U8977 3CH Current Unit	–	Non-isolated
Model U8978 4CH Analog Unit	40 V DC (Direct input) 400 V DC (with Model 9665 10:1 Probe used)	30 V DC, 60 V AC (Direct input) 300 V AC/DC (CAT II) (with Model 9665 10:1 Probe used)
Model U8979 Charge Unit	40 V DC	30 V AC 60 V DC
Model MR8990 Digital Voltmeter Unit	500 V DC	300 V AC/DC (CAT II)

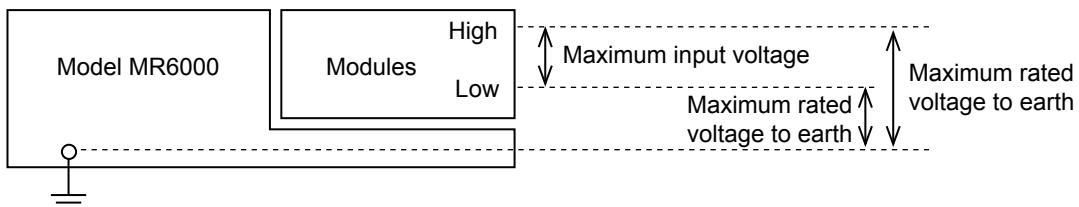

Ratings of connection cords

Connection cord		Maximum input voltage	Maximum rated voltage to earth
Model L9197	Connection Cord	600 V AC/DC	600 V AC/DC (CAT III) 300 V AC/DC (CAT IV)
Model L9198	Connection Cord	300 V AC/DC	600 V AC/DC (CAT II) 300 V AC/DC (CAT III)
Model L9217	Connection Cord		
Model L9790	Connection Cord	600 V AC/DC	<ul style="list-style-type: none"> • With Model L9790-01 Alligator Clip or Model 9790-03 Contact Pin attached 600 V AC/DC (CAT II) 300 V AC/DC (CAT III) • With Model 9790-02 Grabber Clip attached 300 V AC/DC (CAT II) 150 V AC/DC (CAT III)
Model 9322	Differential Probe	2000 V DC 1000 V AC	<ul style="list-style-type: none"> • With grabber clips attached 1500 V AC/DC (CAT II) 600 V AC/DC (CAT III) • With alligator clips attached 1000 V AC/DC (CAT II) 600 V AC/DC (CAT III)
Model L4940	Connection Cord	1000 V DC*	<ul style="list-style-type: none"> • With Model L4935 Alligator Clip or Model L4932 Test Pin attached 600 V AC/DC (CAT IV) 1000 V AC/DC (CAT III) • With Model 9243 Grabber Clip or Model L4936 Bus Bar Clip attached 600 V AC/DC (CAT III) • With Model L4937 Magnetic Adapter Set attached 1000 V AC/DC (CAT III) • With Model L4934 Small Alligator Clip Set attached 300 V AC/DC (CAT III) 600 V AC/DC (CAT II)
Model P9000-01	Differential Probe	1000 V AC/DC	1000 V AC/DC (CAT III)
Model P9000-02	Differential Probe		
Model L9197	Connection Cord	30 V AC 60 V DC	For inputting voltage into Model U8979

*: When Model U8974 High Voltage Unit is used

 DANGER



It is recommended to measure the secondary side of a distribution panel with the U8974 High Voltage Unit. Do not connect the connection cords on the primary side of the distribution panel because an unrestricted current flow can damage the connection cords and facilities if a short-circuit occurs.

 WARNING



Each channel of Model U8979 Charge Unit has the BNC terminal and miniature connector terminal with the common ground. Do not connect cords with each of the terminals simultaneously to avoid a short-circuit.

⚠️ WARNING



- To avoid an electric shock and damage to the module and the instrument, confirm that the instrument is turned off and that the connection cords are disconnected before removing or replacing a module.
- To avoid an electric shock, install a blank panel over any slot with a module removed.
- To prevent the instrument damage or an electric shock, use only the screws that are originally installed for securing the module in place. If you have lost any screws or find that any screws are damaged, please contact your authorized Hioki distributor or reseller.
- Setting the measurement mode to [Preamp] allows Model U8979 Charge Unit to constantly provide power (3.5 mA, 22 V) to sensors. Set any measurement mode other than [Preamp] or turn off the instrument before connecting a sensor or probe with a BNC terminal to avoid an electric shock or damage to the measurement target.

⚠️ CAUTION



- Do not touch module connectors inserted to the instrument to avoid damaging a module.



- Model U8979 Charge Unit has miniature connectors with the maximum input charge of ± 500 pC (for six higher-sensitivity range) or $\pm 50,000$ pC (for six lower-sensitivity range). Inputting a charge that exceeds these values causes damage to the instrument.
- Use an acceleration sensor with a built-in pre-amplifier that conforms to the specification of Model U8979 (3.5 mA, 22 V). Using an inapplicable sensor may cause damaging itself.
- The mounting screws must be firmly tightened or the module may not work as specified, or may even fail.

IMPORTANT

- Install a blank panel over each of the slot with no module installed. If the measurement is performed with no blank panel installed, the instrument may not work as specified because of temperature instability within the modules.
- If any unexpected waveform is observed or a module is not recognized, send the instrument for repair.

- Before carrying the instrument, disconnect all cords and remove the USB flash drive and SD memory card.
- Waveforms can frequently fluctuate even when no voltage is applied due to an induction voltage. This, however, is not a malfunction.
- This instrument may cause interference if used in residential areas. Such use must be avoided unless the user takes special measures to reduce electromagnetic emissions to prevent interference to the reception of radio and television broadcasts.

Precautions During Shipment

Store the packaging materials even after unpacking, because you will need them when you transport the instrument.

CAUTION



To avoid damage to the instrument, protect it from physical shock when transporting and handling. Be especially careful to avoid physical shock due to dropping it.

CD precautions

- Exercise care to keep the recorded side of discs free of dirt and scratches. When writing text on a disc's label, use a pen or marker with a soft tip.
- Keep discs inside a protective case and do not expose to direct sunlight, high temperature, or high humidity.
- Hioki is not liable for any issues your computer system experiences in the course of using this disc.

Handling storage devices

CAUTION



- Do not carry the instrument with a USB flash drive inserted. Damage could result.
- Do not subject the instrument to extreme shock or vibration. Shock can cause damage to the HD unit or built-in SSD unit.
- Inserting a storage device upside down, backward, or in the wrong direction may damage the storage device and instrument.



Exercise care when using such products because static electricity could damage the external storage media or cause a malfunction of the instrument.

IMPORTANT

- Do not extract any external storage device or turn off the instrument while the instrument is accessing the storage device (while the blue **SAVE** key is lighting up). Data stored in the device could be lost.
- No compensation is available for loss of data stored on any external storage device (USB flash drive, SD card) or the built-in HD and SSD units of the instrument, regardless of contents or causes of damage or loss. Be sure to back up any important data stored on the external storage device (USB flash drive, SD card), and the built-in HD and SSD units of the instrument.
- When the instrument is left powered off for a long period of time (about one year or more), the data saved to the built-in SSD may be lost. Be sure to back up the data if the instrument is to be left powered off for a long time.

- With some external storage device, the instrument may not start up if power is turned on while the device is inserted. In such a case, turn off and cycle the instrument.
- The instrument does not support certain types of USB flash drives, such as those that require fingerprint authentication or a password.
- Number of writes for the external media (USB flash drive, SD memory card) and the built-in SSD unit of the instrument is limited by their flash memory. If data has been rewritten many times, data reading and writing capabilities will be degraded. In that case, replace the device.

- Media that can be used to save data is as follows. Use the product available as Hioki's option only. (p. 5)
Model Z4006 USB Drive
Model Z4001 SD Memory Card (2 GB)
Model Z4003 SD Memory Card (8 GB)
Model U8333 HD Unit (built-in)
Model U8332 SSD Unit (built-in)

Before connecting cords

For detailed precautions and instructions on connections, refer to the instruction manuals of your connection cords.

DANGER

- If the insulation on a connecting cord melts, the metal conductor may be exposed. Do not use any cord whose metal conductor is exposed. Doing so could result in an electric shock, burn, or other hazards.

When measuring power line voltage



- Only connect connection cords on the secondary side of a distribution panel. If a short-circuit occurs on the secondary side of the distribution panel, the panel will interrupt the short-circuit current. Do not connect the connection cords on the primary side of the distribution panel because an unrestricted current flow can damage the connection cords and facilities if a short-circuit occurs.
- To prevent an electrical shock and bodily injury, do not touch any input terminals on the VT (PT), CT or the instrument when they are in operation.
- Do not leave the measurement cords connected to the instrument in an environment where voltage may surge beyond the maximum input voltage. Applying voltage may result in damage to the instrument, or serious accidents.
- Do not cause a short-circuit between another wire and the wire to be measured with the metal tip of the connection cord. Arcs or such grave accidents are likely to occur.
- To avoid a short-circuit or electric shock, do not touch the metal tip of the connection cord.

WARNING



- To prevent an electric shock, confirm that the white or red portion (insulation layer) inside the cable is not exposed. If a color inside the cable is exposed, do not use the cable.
- Do not place a cord in contact with the lines to be measured. Any contact can cause the instrument to malfunction and lead to a short-circuit or electric shock, resulting in bodily injury.



- Use only the specified connection cords. Using a non-specified cord may result in unsafe measurements. Using a non-specified cord may also result in incorrect measurements due to poor connection or other reasons.
- To avoid electric shock, do not exceed the lower of the ratings shown on the modules and connection cords.

CAUTION



- To prevent cord damage, do not step on cords or pinch them between other objects. Do not bend or pull on cords at their base.

⚠ CAUTION

- The cable is hardened in freezing temperatures. Do not bend or pull it to avoid tearing its shield or cutting the cable.
- Do not use any cable terminated with a metal BNC connector for connecting cables to the BNC jacks on modules. If you connect a metal BNC cable to insulated BNC connector, the insulated BNC connector and instrument may be damaged.

Before connecting a logic probe to a measurement target**⚠ DANGER**

To avoid an electric shock, a short-circuit and damage to the instrument, supply power from a single main to the instrument and a measurement target with the accompanying power cord.

The ground pin of logic terminal of Model 9320-01 Logic Probe (or Model 9327 Logic Probe) is not isolated from the instrument ground. The ground is shared. If each of the terminals are supplied with power from separate mains or power is supplied through a non-grounded power cord, the measurement target and the instrument may be damaged because a current may flow through the logic probe due to the resulting ground potential difference between the terminals. The following connection procedure is recommended to avoid this problem:

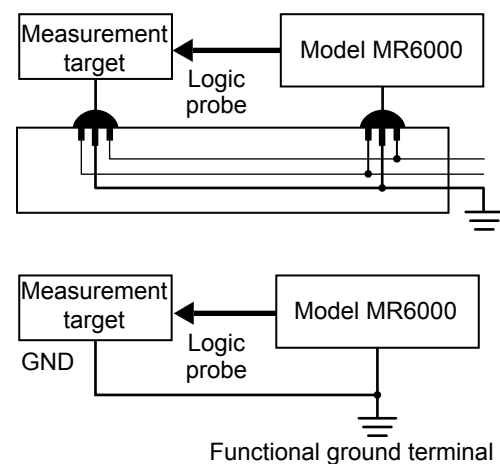

- Connect the accompanying power cord to the instrument and supply power from a single outlet as the measurement target.
- Connect the ground of the measurement target to the GND terminal (functional earth terminal) of the instrument.
(Always supply power from a single main.)
Refer to “2.9 Supplying Power to the Instrument” (p. 63).

**Before turning on the instrument****⚠ WARNING**

- To prevent electrical shock and to maintain the safety specifications of this instrument, connect the accompanying power cord only to an inlet.
- Before turning the instrument on, make sure the supply voltage matches that indicated on its power connector. Connection to an improper supply voltage may damage the instrument and present an electrical hazard.

⚠ CAUTION

Do not operate the instrument on any of the power sources that provide rectangular-wave or pseudo-sine-wave power (UPS or uninterruptible power supply, DC/AC inverter). Doing so may damage the instrument.

Before connecting the instrument to external equipment

DANGER



To avoid electrical hazards and damage to the instrument, do not apply voltage exceeding the rated maximum to the external control terminals.

Model MR6000

I/O terminals	Maximum input voltage
IN1	10 V DC
IN2	10 V DC
OUT1	50 V DC, 50 mA, 200 mW
OUT2	50 V DC, 50 mA, 200 mW
TRIG.OUT	50 V DC, 50 mA, 200 mW
EXT.TRIG	10 V DC

I/O terminals	Maximum input voltage
EXT.SMPL	10 V DC

WARNING

To avoid an electric shock or damage to the equipment, always observe the following precautions when connecting your external equipment to external control terminals.



- Always turn off the instrument and any equipment to be connected before making connections.
- Be careful to avoid exceeding the ratings of the external control terminals.
- Properly isolate the devices and systems to be connected to the external control terminals from one another.

CAUTION



- Use a common ground to both the instrument and the connected equipment. Using different ground circuits will result in a ground potential difference between the instrument and the connected equipment. If the communications cable is connected while such a potential difference exists, it may result in equipment malfunction or failure.
- Before connecting or disconnecting any communication cable, always turn off the instrument and your device to be connected. Failure to do so could result in an equipment malfunction or damage to the equipment.
- After connecting the communications cable, tighten the screws on the connector securely. Failure to do so could result in an equipment malfunction or damage to the equipment.
- To prevent damage to the equipment, use the recommended type of wires to connect your external equipment to the external control terminal, or otherwise ensure that the wires have sufficient withstand voltage and current capacity. Refer to “2.5 Connecting the External Control Terminals” (p. 55).

How to Refer to This Document

How to open a screen

Indicates the order of tapping the screens.

The button  represents the setting key.

Procedure numbers

Numbered same as a corresponding step-by-step instruction.

Options and explanations

Describes options available when an item is tapped.

The icon indicates the default setting of the item.

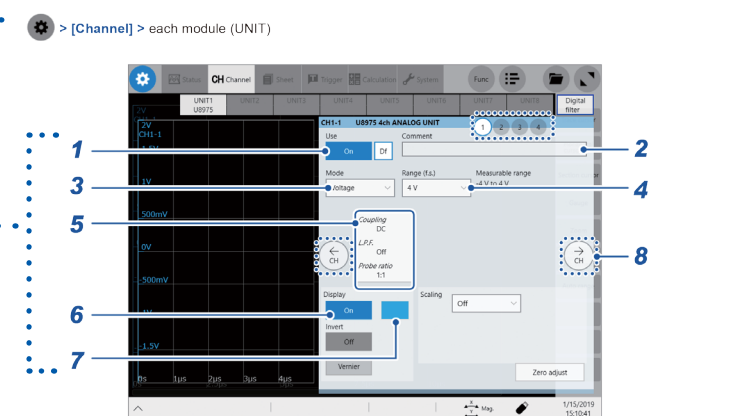

- 1 Tap the [Use] button to set it to [On] or [Off].

On <input checked="" type="checkbox"/>	Measures a waveform through this module.
Off <input type="checkbox"/>	Does not measure any waveform through this module. Since no data is acquired, the instrument displays or saves nothing.

- 2 Enter a comment in the [Comment] box.
Number of characters that can be entered: up to 40
- 3 Tap the [Mode] box, and then choose a measurement mode from the list.

Voltage <input checked="" type="checkbox"/>	Measures a waveform in voltage mode.
Temperature <input type="checkbox"/>	Measures a waveform in temperature mode.

Selectable modes vary depending on the installed modules.
Refer to "3.6 Configuring Module-Specific Settings" of Instruction Manual.

- 4 Tap the [Range (f.s.)] box, and then choose a measurement range from the list.
The measurement ranges that can be chosen varies depending on modules.
If an input voltage exceeds the measurable range (overrange), change the measurement range to one with a lower sensitivity.

1.1 Product Overview and Features

This recorder allows you to observe a wide range of waveforms from low-speed signals to high-speed waveforms.

You can mainly use this instrument for analyzing test and evaluation results of various products and troubleshooting those products.

● High-speed sampling rate: 200 M sampling

The high-speed sampling rate allows capturing instantaneous changes such as PWM switching waveforms of inverters.

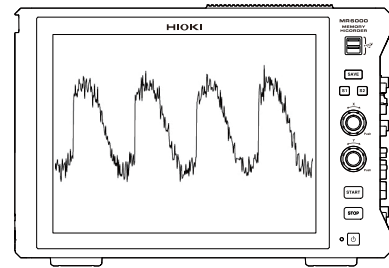

● Extensive line of measurement modules

Many types of measurement modules let the instrument measure a variety of signals that include voltage, current, temperature, and frequency.

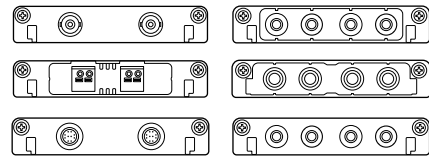

● Real-time save function

Recording the waveform data to optional media allows measurements with high-speed and for long durations.

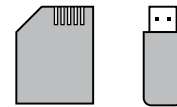

● The touch panel allows intuitive operations.

The touch panel allows intuitive operations.

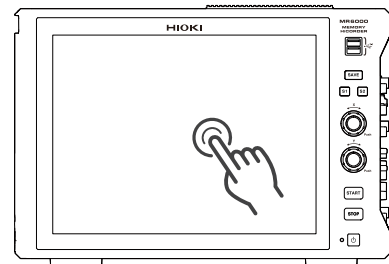

1.2 Name and Function of Each Part

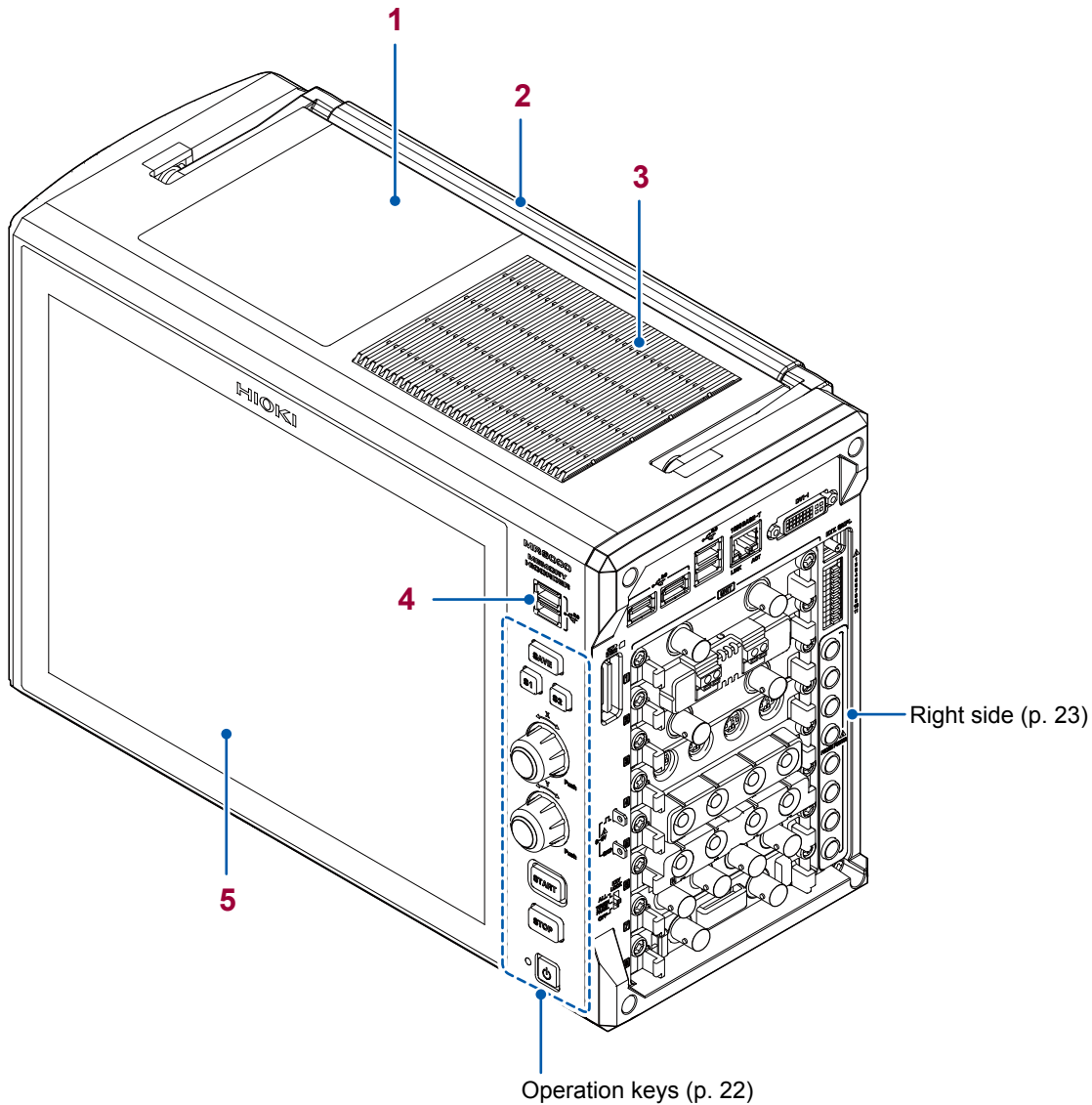

No.	Name	Function	Reference
1	Media box	Holds the SSD or HD unit. One port is available for USB3.0 connector (dedicated to USB flash drives). Always use the instrument with the cover closed.	p. 62
2	Handle	The handle used to carry the instrument.	—
3	Vents	These holes provide ventilation to prevent the internal temperature of the instrument from increasing to a high temperature.	p. 8
4	USB 2.0 connector	Connect a USB flash drive, USB mouse, or USB keyboard.	p. 59
5	Display	The 12.1-inch TFT color LCD equipped with the capacitive touch panel	p. 24

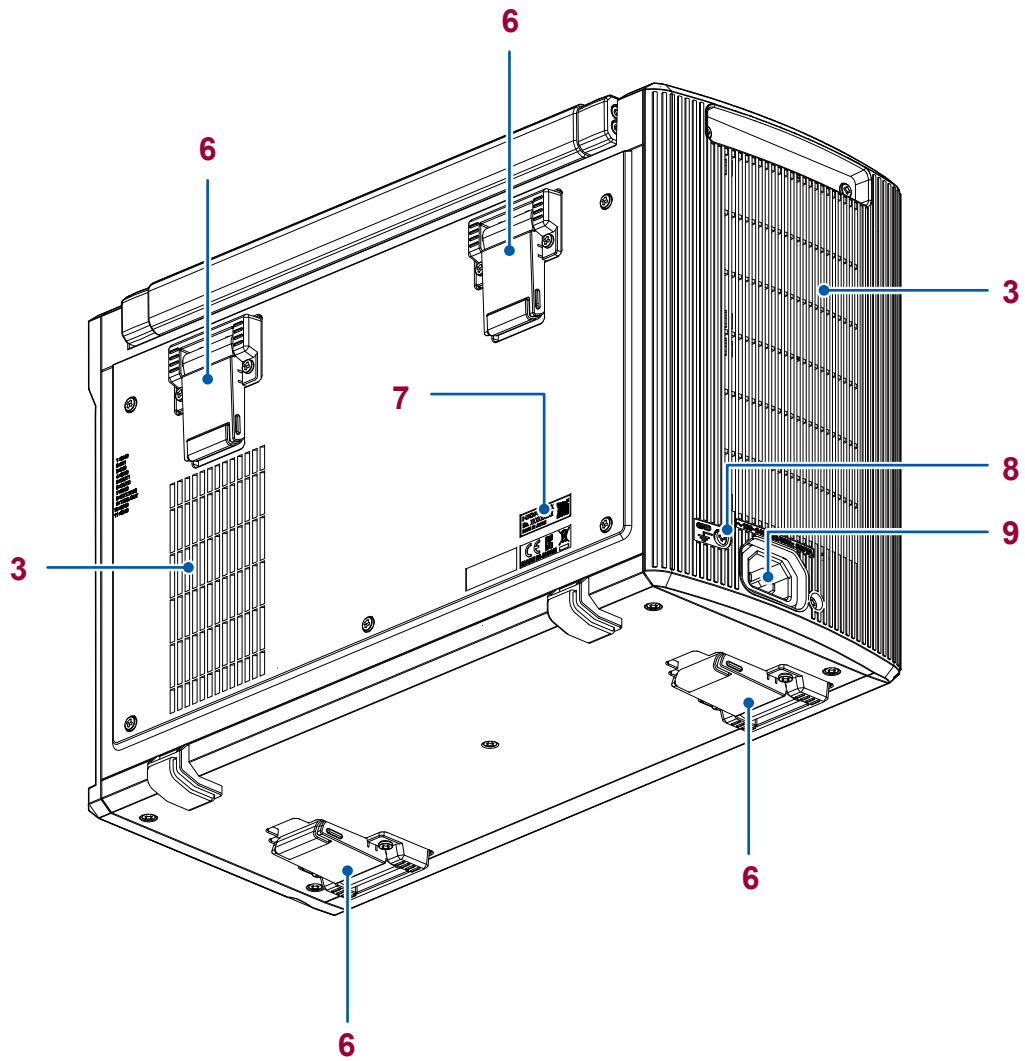

No.	Name	Function	Reference
6	Feet	These feet are used to incline the instrument for better visibility of the screen.	–
7	Serial number	The serial number consists of nine digits. The first two (from the left) indicate the year of manufacture, and the next two indicate the month of manufacture. Required for product control. Do not remove this label. Inform your authorized Hioki distributor or reseller of this number if required.	–
8	GND terminal (Functional earth terminal)	Connects this terminal to a grounded conductor.	p. 15 p. 63
9	Power inlet	Connects the power cord provided.	

Operation keys

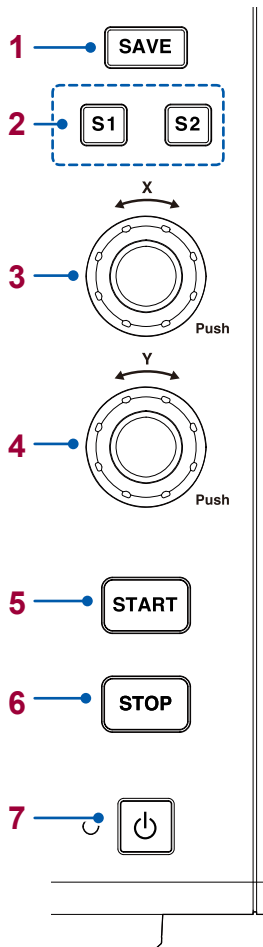

No.	Name	Function	Reference
1	SAVE key	Opens the manual-save dialog box. Lights up in blue while accessing the storage device.	p. 78
2	Shortcut keys	Frequently-used settings can be registered on the keys.	*
3	Rotary knob X	Allows you to choose a sampling rate and moves the cursors.	p. 28
4	Rotary knob Y	Allows you to choose a measurement range and moves waveform positions.	
5	START key	Starts a measurement. Lights up in green during a measurement.	p. 77
6	STOP key	Pressing the key once: Acquires the recording length of waveforms before stopping the measurement. Pressing the key twice: Stops the measurement.	
7	Power key	Used to turn on and off the instrument.	p. 63

*: "11 Configuring the System Environment Settings" of Instruction Manual

IMPORTANT

Do not press several operation keys simultaneously. Besides, do not execute excessively consecutive actions. Doing so may cause unstable behavior of the instrument.

Right side

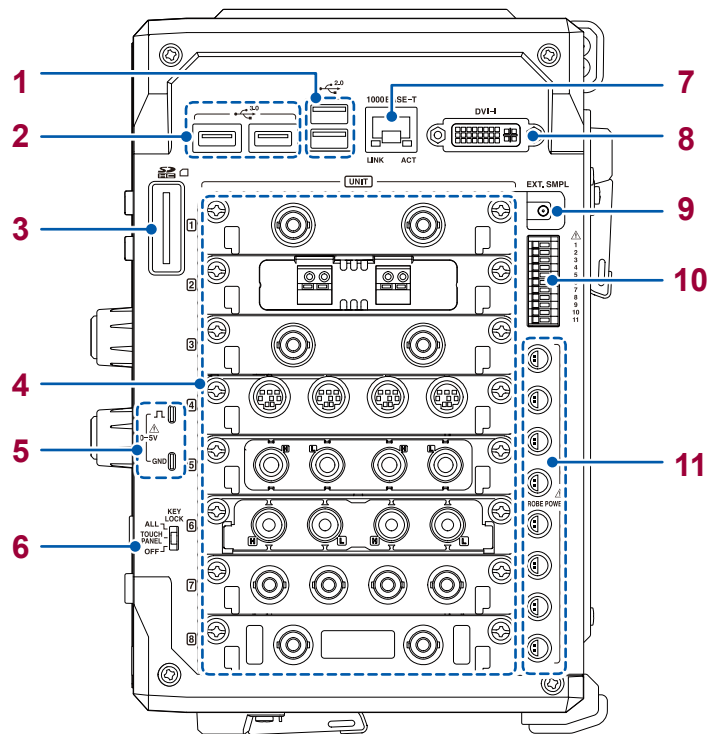

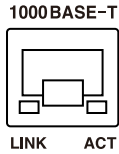
No.	Name	Function	Reference
1	USB 2.0 connector	Connect a USB flash drive, USB mouse, or USB keyboard.	p. 59
2	USB 3.0 connector		
3	SD memory card slot	Insert an SD memory card.	p. 59
4	Modules	Install modules required for measurement targets.	p. 9 p. 38
5	Probe compensation signal output terminal	Outputs the signals to compensate Model 9665 10:1 Probe or Model 9666 100:1 Probe for influences.	p. 42
6	KEY LOCK	Disables the touch panel and key operation.	p. 33
7	1000BASE-T connector 	Attach a LAN cable to connect the instrument to your network. ACT LED Blinking: Communicating data LINK LED Green light: 1000BASE Yellow light: 100BASE Off: 10BASE	p. 57
8	DVI-I terminal	Outputs the screen data signal (digital or analog).	–
9	External sampling terminal	Input an external sampling signal.	p. 54
10	External control terminals	Input external signals to control the instrument.	p. 16 p. 55
11	Dedicated power terminal for current sensors	Model Z5021 Probe Power Unit (optional) can be installed.	p. 14 p. 53

1.3 Screen

Screen configuration

Waveform screen (p. 25)



Setting screen



Status

This screen is used to set the measurement conditions such as the sampling rate, recording length (shot), and saving data. Refer to “3.2 Setting Measurement Conditions” (p. 70).



Channel

This screen is used to configure the input channel settings such as the measurement range and low-pass filter. Refer to “3.3 Configuring the Input Channel settings” (p. 72) and “1 Digital-Filter Calculation” of MR6000-01 Dedicated Functions.

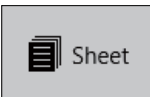

Sheet

This screen is used to configure a display settings for each sheet. Choose channels to be displayed on each sheet. Refer to “1.4 Configuring the Sheet Settings” of Instruction Manual.



Trigger

This screen is used to configure the trigger settings. Refer to “3.4 Configuring the Level Trigger Settings” (p. 75).

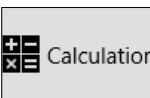

Calculation

This screen is used to configure the settings of the numerical, waveform, FFT, real-time waveform (Model MR6000-01 only) calculations. Refer to “7 Numerical Calculation Function” of Instruction Manual, and “2 Real-time Waveform Calculation” of MR6000-01 Dedicated Functions.

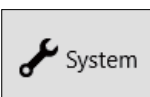

System

This screen is used to configure the system environment, communications, and external control terminal settings, and to initialize the instrument. You can also check the instrument configuration on this screen. Refer to “6.2 Initializing the Instrument” (p. 139).

Explanation of each screen

Waveform screen

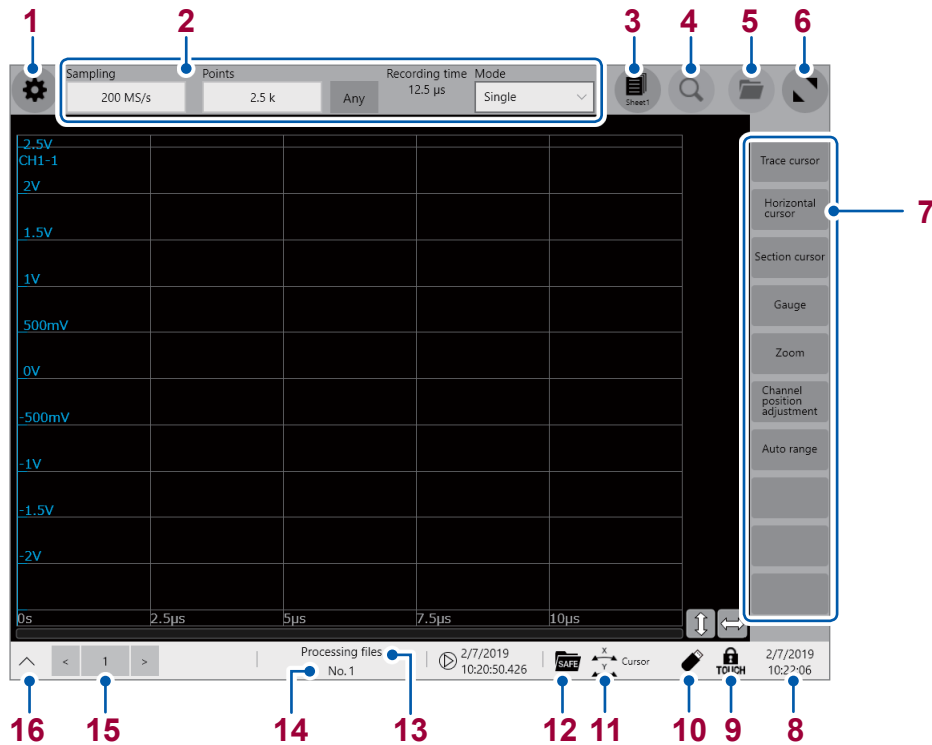

No.	Item	Description	Reference
1		Switches between the setting and waveform screens.	p. 70, p. 83
2	Measurement condition setting	Allows you to choose a sampling rate, recording length (the number of points and user-defined length), and recording mode (single or repeat).	p. 70
3	Sheet selection	Switches among preset sheets.	*1
4	Search setting screen	Allows you to specify search conditions.	*2
5	File screen	Opens the file screen.	*3
6	Waveform area zooming-in	Zooms in the waveform area.	–
7	Function buttons	Allows you to choose a function among those available on the waveform screen.	p. 83
8	Current date and time	Displays the current date and time.	p. 64
9	KEY LOCK state	Indicates a key lock state.	p. 33
10	Eject button	Ejects a USB flash drive or SD memory card.	p. 60
11	Rotary knob setting	Indicates functions assigned to the rotary knob. Each time you press the rotary knob, the function is switched.	p. 28
12	System protection state	Indicates the system protection state.	*4
13	Processing state	Indicates the processing state of the instrument.	–
14	Measurement count	Displays the measurement count.	–
15	Displayed-block number	The number of the block displayed on the waveform screen with the memory division enabled	*5
16		Displays the quick-access menu.	p. 32

- *1: Refer to “1.4 Configuring the Sheet Settings” of Instruction Manual.
- *2: Refer to “6 Search Function” of Instruction Manual.
- *3: Refer to “4 Saving/Loading Data and Managing Files” of Instruction Manual.
- *4: Refer to “11 Configuring the System Environment Settings” of Instruction Manual.
- *5: Refer to “10.2 Configuring the Display Settings” of Instruction Manual.

Cross-screen functions

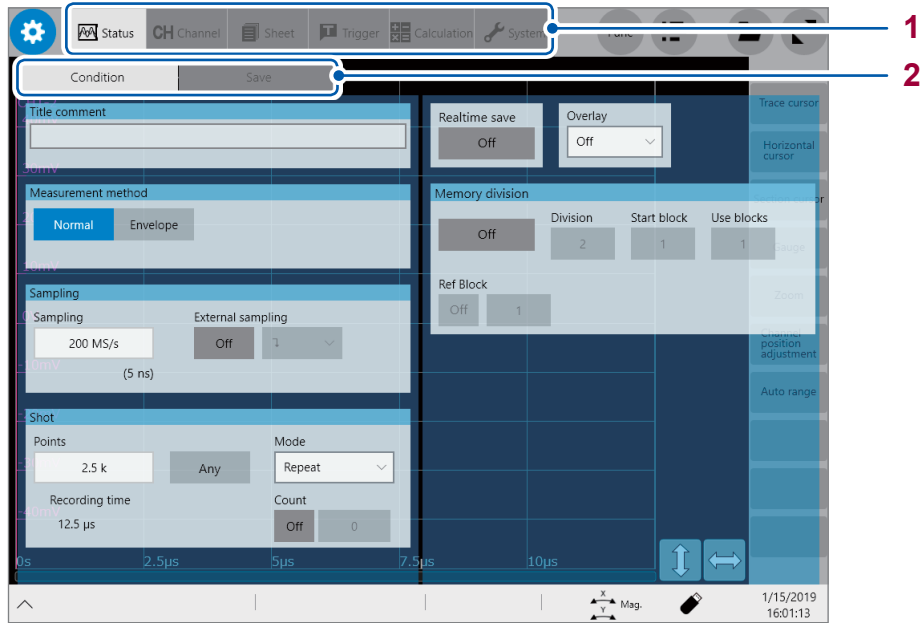





No.	Name	Description
1	Menu tab	Tap a tab to choose a menu to open.
2	Sub-menu tab	Tap a tab to choose a sub-menu to open.

1.4 Basic Operation

Touch panel

The touch panel allows the following operations.

Touch operation	Description
 Tap	“Tap” means to touch the display with a finger and then to lift the finger quickly.
 Drag	“Drag” means to choose something shown on the display with a finger by touching it and to slide the finger while touching the display. To scroll through screens or waveforms, drag them.
 Pinch in	“Pinch in” means to move the thumb and a finger (or two fingers) together while touching the display.
 Pinch out	“Pinch out” means to move the thumb and a finger (or two fingers) apart while touching the display.
 Swipe	“Swipe” means to move a finger quickly across the display while touching it.

Rotary knob

Push the rotary knob to choose an action and turn the knob to perform the action.

Operation of the rotary knob

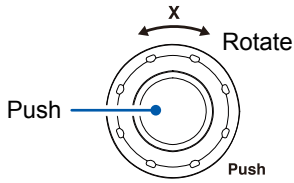

Each time you push the rotary knob X, the following actions are chosen one after another.

Magnification/demagnification ratio	Changes the magnification/demagnification ratio of waveforms acquired across all channels in the horizontal axis direction.
Position	Changes the display position of waveforms acquired across all channels in the horizontal axis direction.
Cursor	Moves the chosen cursor.
Setting	Changes the sampling rate.

Operation for the rotary knob Y

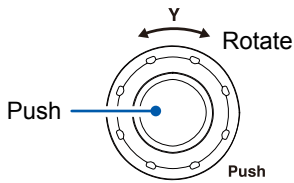

Each time you push the rotary knob X, the following actions are chosen one after another.

Magnification/demagnification ratio	Changes the display magnification of the chosen channel in the vertical axis direction.
Position	Changes the display position of the chosen channel in the vertical axis direction.
Cursor	Moves the chosen cursor.
Setting	Changes the measurement range. This operation can be used on the waveform screen only.

When you operate a rotary knob, the channel selection panel is displayed, which allows you to choose an channel to be operated by tapping the [←] or [→] button. In addition, you can directly choose a channel to be operated by tapping a channel marker.

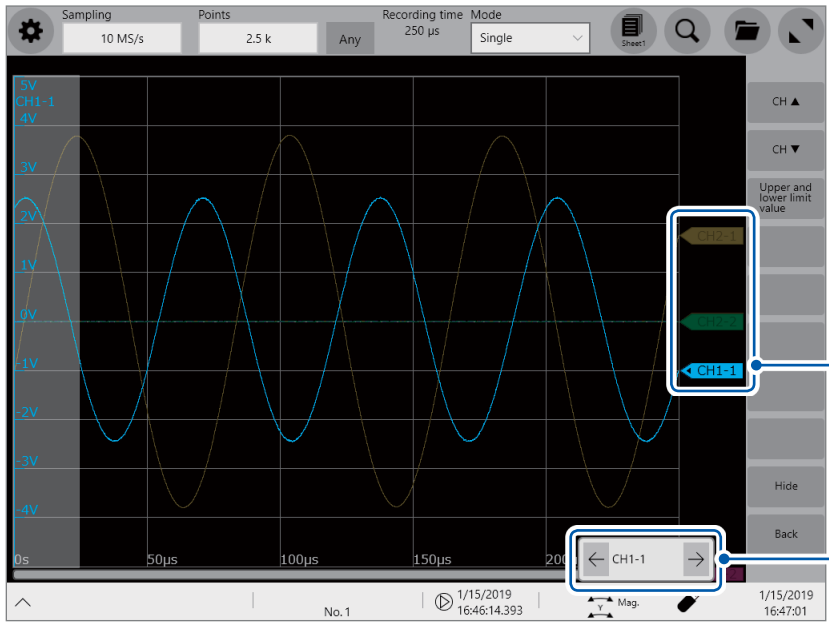

Tap a channel marker.

Choose a channel.

Changing screens and settings

Switching between the waveform and setting screens

Tap the button  to switch between the waveform and setting screens.

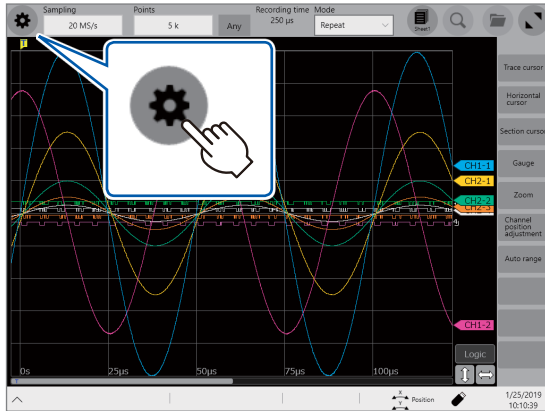

Waveform screen

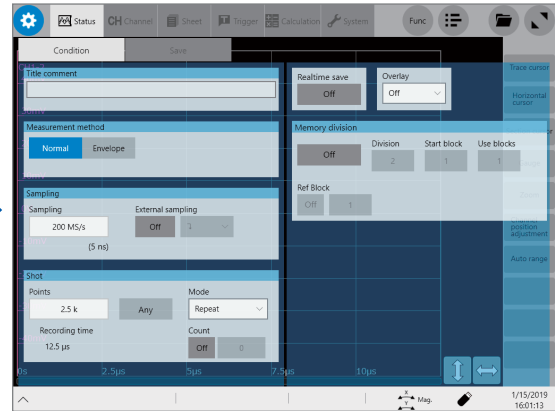

Setting screen

Switching the setting screens

Tap a tab to switch the setting screens.

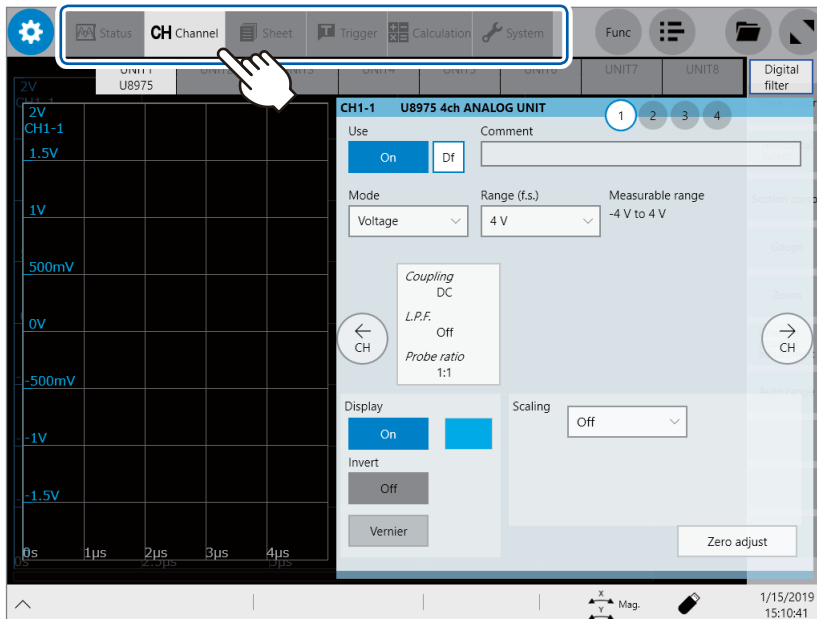

Choosing an option from a list

Example: Choosing a sampling rate



Example: Choosing a measurement range of Model 8966

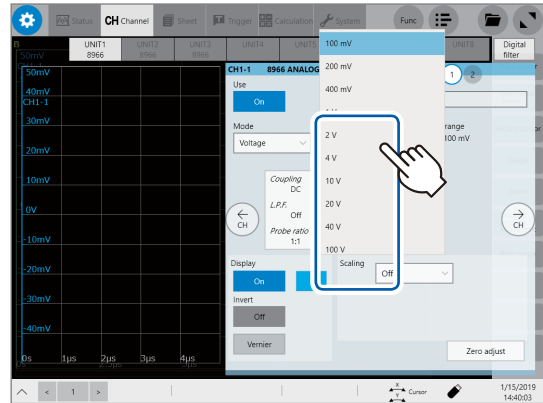

Entering numerical values

Example: Entering a user-defined recording length

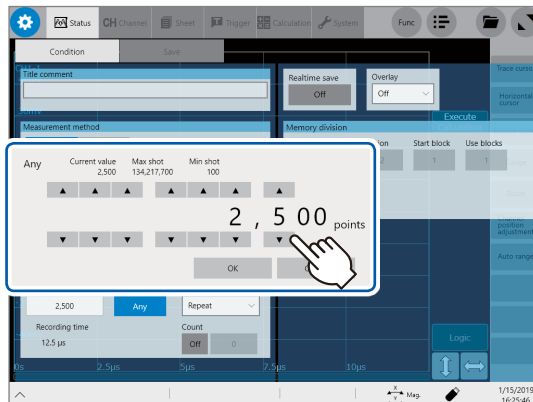

Example: Entering a scaling ratio

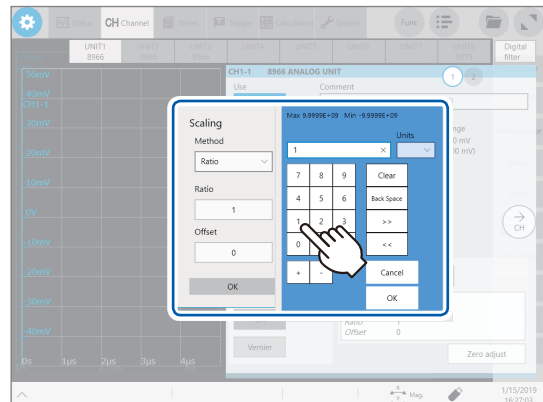

Quick-access menu

The quick-access menu allows various operation that includes undoing the action and switching over to the entire waveform display.

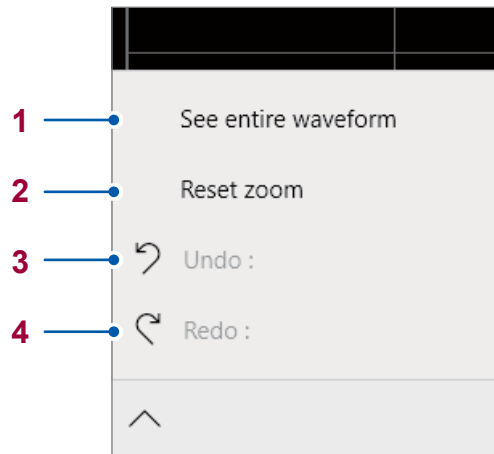

No.	Item	Description
1	See entire waveform	Displays the recording length of the waveforms so that they fit the single screen width. If the recording length is relatively long, displaying the waveforms may require a lot of time.
2	Reset zoom	Displays the waveforms at the default display magnification.
3	Undo	Cancels the previous action, which restores the instrument to the previous setting.
4	Redo	Performs the action canceled by tapping [Undo].

- You cannot restore the instrument to a former condition after performing an action that includes the following actions: loading data, restoring data to the default condition, executing the auto-range, and sending a communication command.
- You cannot retrieve measurement waveforms.

Key lock

The key lock function disables touch panel operation and key operation to prevent an operation error during measurement.

Even if the key lock is engaged, the external control terminal and remote operation are enabled.

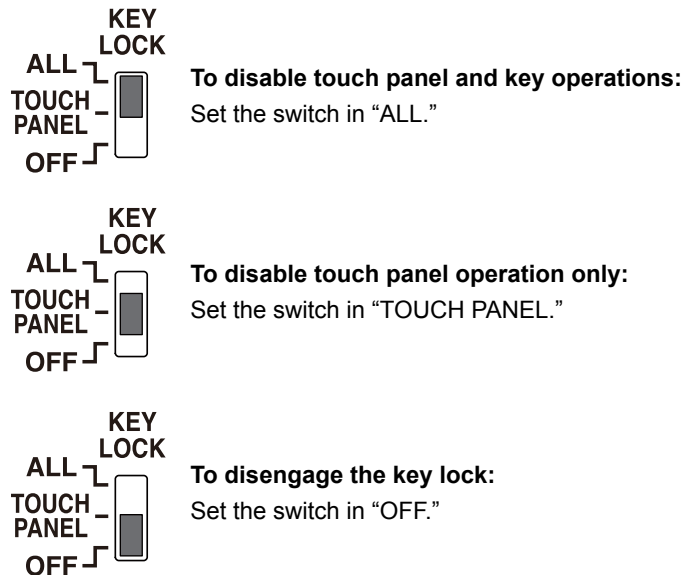
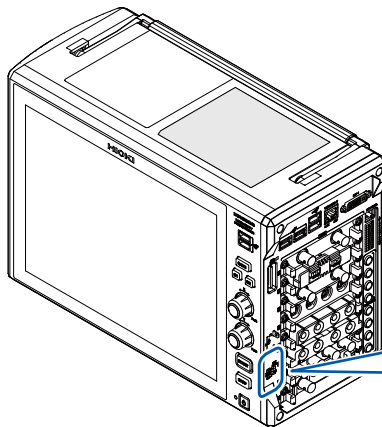

1

Overview

Help function (Displaying manuals)

The screen can display the HTML file of a selected manual.

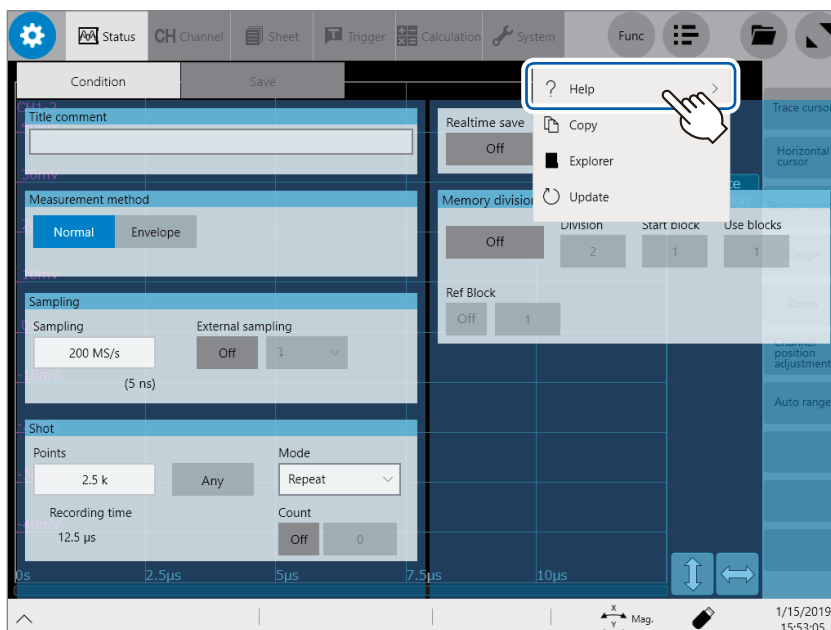

 > [Func] > [Help]



Mouse operation

Using a commercially available USB mouse enables you to operate the instrument as with the touch panel.

Basic mouse operation for the instrument is as follows:

Mouse operation	Touch panel operation	Description
 Click		Same action as tapping the screen. Allows you to choose a menu or execute an action.
 Wheel button	–	Changes options to be selected.
 Up/down/left/right	–	Moves the mouse cursor around.

External noise may cause the mouse to malfunction. Keep the mouse and mouse cable as far away as possible from sources of noise.







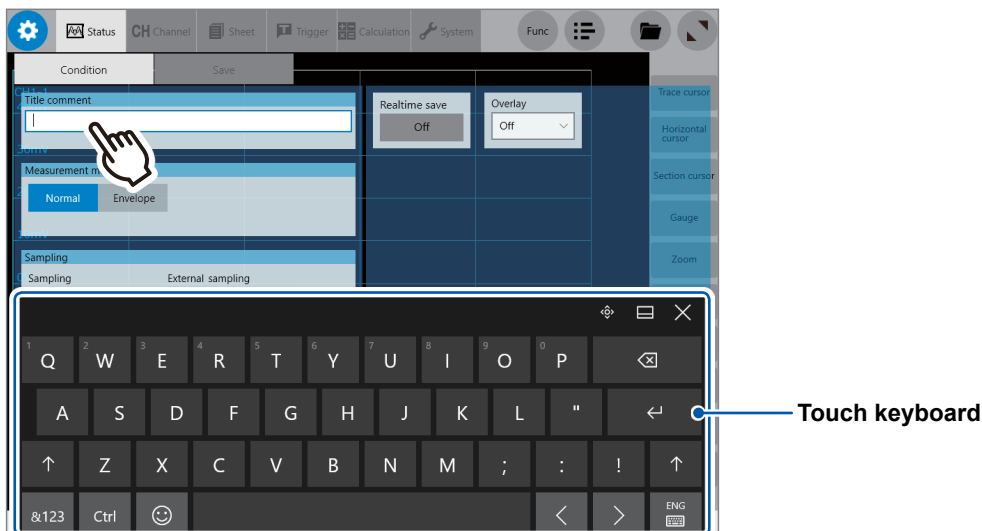

Use the mouse on an insulated table. Some mice commercially available are susceptible to noise and using such a mouse on a metal table may cause the instrument to malfunction.

Touch keyboard

Tapping a comment box allows you to enter characters with the touch keyboard.

Refer to “3.2 Setting Measurement Conditions” (p. 70) and “3.3 Configuring the Input Channel settings” (p. 72).







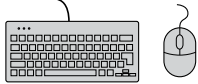
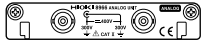
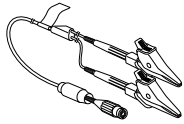

Icon	Description
	You can drag and move the keyboard. The icon  appears to the left of this icon. Each tap switches between the icon  and the icon  .
	You cannot drag the keyboard. Each tap switches between the icon  and the icon  .
	Closes the keyboard.

2

Preparing for Measurement

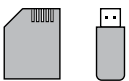
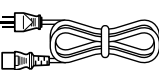
Carefully read “Operation Precautions” (p. 8) before starting preparation.

Keyboard, mouse  (p. 34)	Modules  (p. 38)	Connection cords  (p. 40)	External sampling  (p. 54)
External control terminals  (p. 55)	Computer  (p. 57, p. 87)	Storage devices  (p. 59)	Power cord  (p. 63)
Setting the clock  (p. 64)	Zero-adjustment  (p. 65)		

2

2.1 Installing and Removing Modules

If you order the instrument with modules specified, the instrument will be delivered with the modules pre-installed. Follow the procedures below to install a module additionally, replace modules, or remove a module. Up to four modules of Model 8971 Current Unit can be installed to the instrument. Up to three modules of Model U8977 3CH Current Unit can be installed to the instrument.

Refer to “Handling the instrument and modules” (p. 10).

Required items: Phillips-head screwdriver (No. 2)

How to install a module

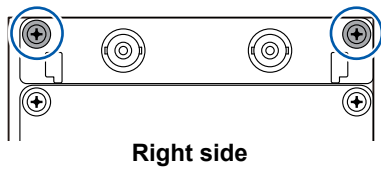

- 1** Orient and insert the module all the way into the instrument.
- 2** Tighten the two screws with the Phillips-head screwdriver to secure the module.

How to remove the module

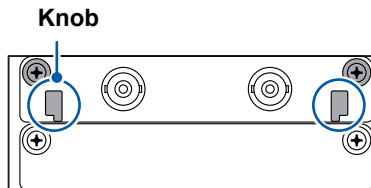

- 1** Loosen the two module mounting screws with the Phillips-head screwdriver.
- 2** Pinch the two knobs and pull out the module.

When not installing any module after removal

Install a blank panel. To order additional blank panels, contact your authorized Hioki distributor or reseller.

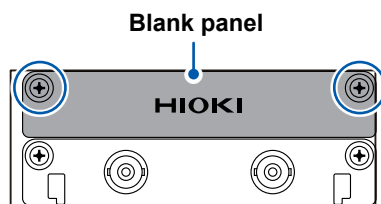

- 1** Place a blank panel.
- 2** Tighten the two screws with the Phillips screwdriver to secure the blank panel.

Allocation of modules and channels

Module numbers

Modules are numbered beginning at the top.

Channel numbers

The channels are numbered beginning from the top left.

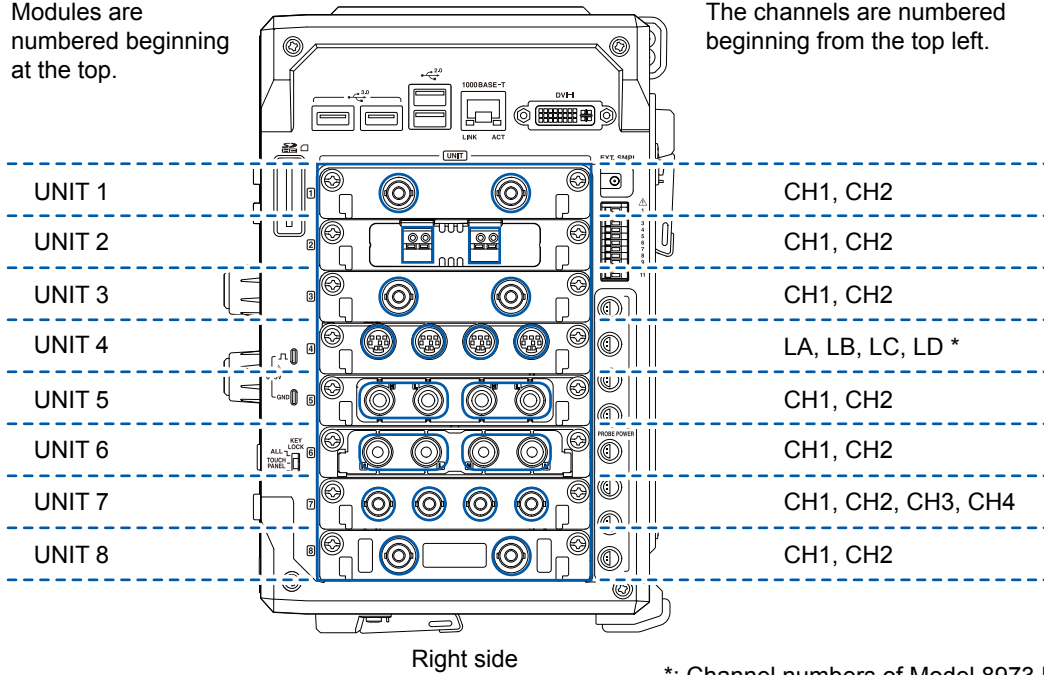

*: Channel numbers of Model 8973 Logic Unit

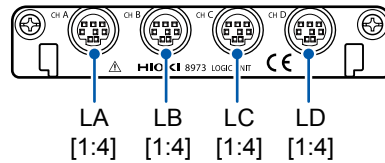

You can find out information about the modules installed in the instrument in [\[System information\]](#). Refer to “System configuration check” (p. 150).

> [\[System\]](#) > [\[System information\]](#)

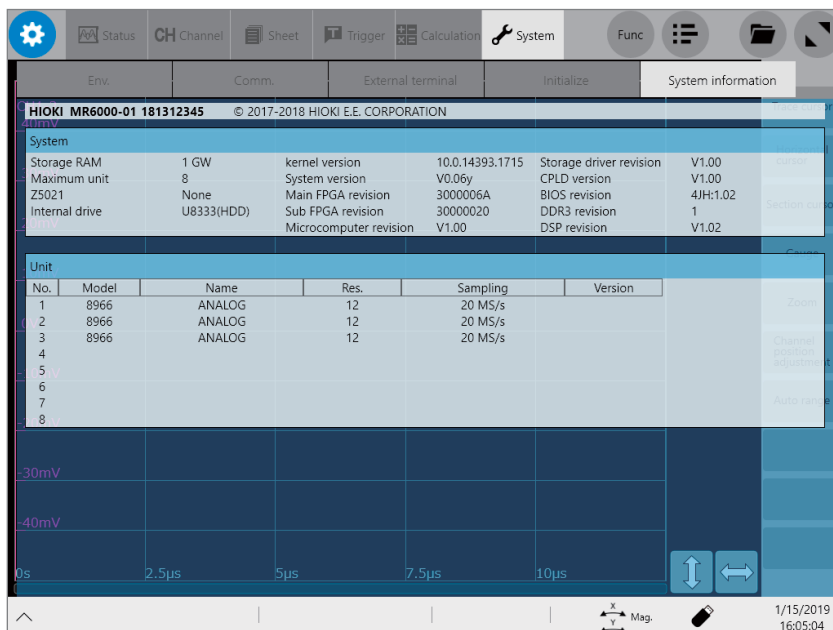

2.2 Attaching Connection Cords

Refer to the instruction manual of each module and each connection cord if provided.

Measurement target	Applicable module		Cord to be connected		Reference
Voltage	Model 8966	Analog Unit	Model L9197	Connection Cord	p. 14 p. 41
	Model 8968	High Resolution Unit	Model L9198	Connection Cord	
	Model 8972	DC/RMS Unit	Model L9217	Connection Cord	
	Model U8975	4ch Analog Unit	Model L9790	Connection Cord	
	Model U8976	High Speed Analog Unit	Model 9665	10:1 Probe	
	Model U8978	4CH Analog Unit	Model 9666	100:1 Probe	
	Model U8979	Charge Unit*	Model 9322	Differential Probe	
Frequency Rotation speed Count	Model 8970	Freq Unit	Model P9000-01	Differential Probe	
			Model P9000-02	Differential Probe	
Temperature	Model 8967	Temp Unit	Thermocouple		p. 43
Vibration Load Pressure Acceleration Torque Displacement	Model U8969	Strain Unit	Strain gauge transducer		p. 44
	Model U8979	Charge Unit	Acceleration sensor		p. 49
Current	Model 8971	Current Unit	Current sensor		p. 46
	Model U8977	3CH Current Unit			
Logic signal	Model 8973	Logic Unit	Model 9320-01	Logic Probe	p. 51
			Model MR9321-01	Logic Probe	
			Model 9327	Logic Probe	
Voltage (precision)	Model MR8990	Digital Voltmeter Unit	Model L2200	Test Lead	p. 51
High voltage	Model U8974	High Voltage Unit	Model L4940 Connection Cable Set		p. 52

*: Model 9166 Connection Cord can be used for Model U8979 Charge Unit only.

Connection cords (For measuring voltage, frequency, or rotation speed, and obtaining accumulations)

Insert connection cords to modules. Choose an appropriate connection cord based on the maximum input voltage and tips of cords.
 The maximum input voltage of the instrument or connection cord, whichever is lower, is applicable.
 Refer to “Before connecting cords” (p. 14).

Required items: Connection cords

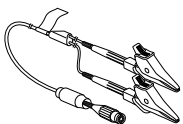
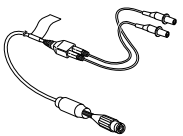
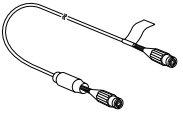
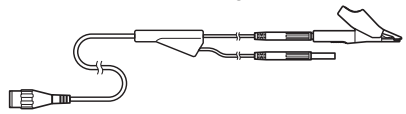
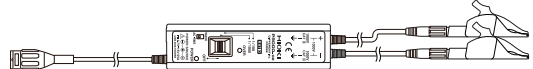
Connection cord	Maximum input voltage	Terminal type
Model L9197 Connection Cord 	600 V	Large alligator clip
Model L9198 Connection Cord (for lower voltage) 	300 V	Small alligator clip
Model L9217 Connection Cord 	300 V	BNC output
Model L9790 Connection Cord Example: with the alligator clip attached. 	600 V	Alligator clip Grabber clip Contact pin
When the voltage of a measurement target exceeds the maximum input rating of the module being used, use any of the following probes: Model 9665 10:1 Probe* ¹ Model 9666 100:1 Probe* ¹ Model 9322 Differential Probe* ² Model P9000-01 Differential Probe* ³ Model P9000-02 Differential Probe* ³ Example: Model P9000-02 Differential Probe 		Alligator clip

*1: The maximum rated voltage to earth depends on a module to be used.
 *2: An optional power cord or AC adapter is required.
 *3: An optional AC adapter or a commercially available USB cable is required.

How to connect a cord

Example: Model 8966 Analog Unit

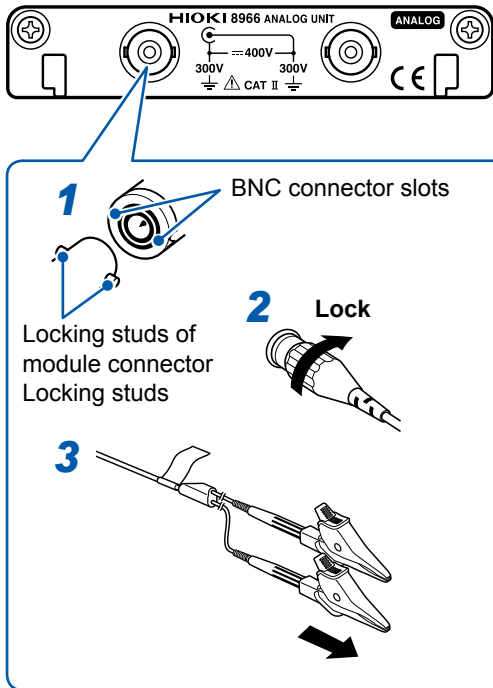

- 1** Align the slots in the BNC connector of a connection cord with the locking studs of a BNC connector on the module, and insert the connector.
- 2** Turn the BNC connector of the connection cord clockwise until it locks.
- 3** Connect the connection cord clips to a measurement target.

How to disconnect the cord

Turn the BNC connector of the connection cord counterclockwise, and then pull out the connector.

When using Model 9665 10:1 Probe or Model 9666 100:1 Probe

Connect the probe tips to the probe compensation signal output terminals of the instrument to compensate the probe for influences before use.

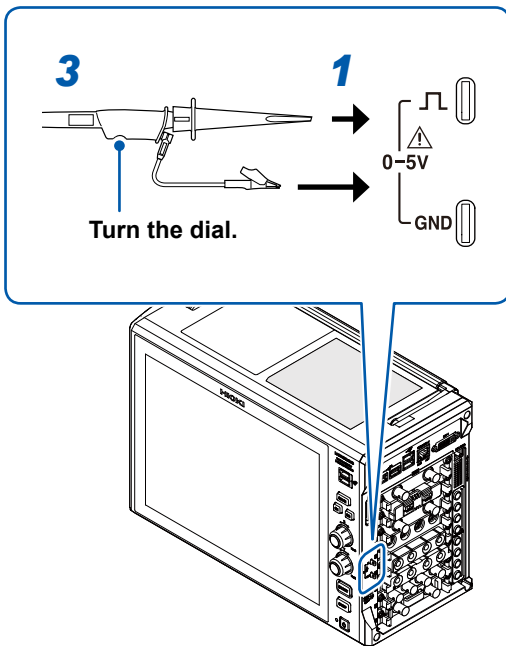

- 1** Connect the probe tips to the probe compensation signal output terminals of the instrument.
- 2** On the instrument, select **[System] > [External terminal]** to set **[Probe compensation signal output]** to **[On]** (p. 56).

A square wave (1 kHz, 0 V to 5 V) outputs from the probe compensation signal output terminals of the instrument.

- 3** Adjust the waveform by turning the dial of the probe grip.

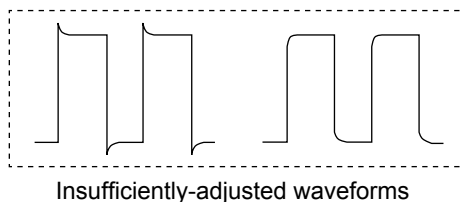
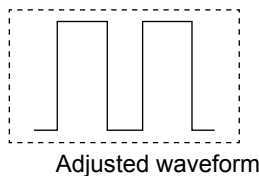

Thermocouple (Temperature)

Connect thermocouples to Model 8967 Temp Unit.

Required items: Thermocouple and flat-blade screwdriver (2.6-mm-width blade)

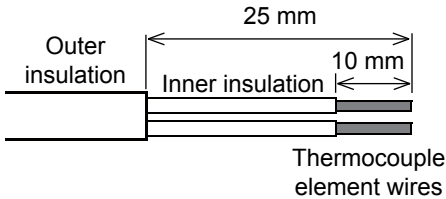

Recommended cable

Compatible wire: Thermocouple element wires with a diameter of 0.4 mm to 1.2 mm
 Standard insulation stripping length: About 10 mm
 Strip the insulation of the thermocouple wires as shown on the left.

How to connect a thermocouple

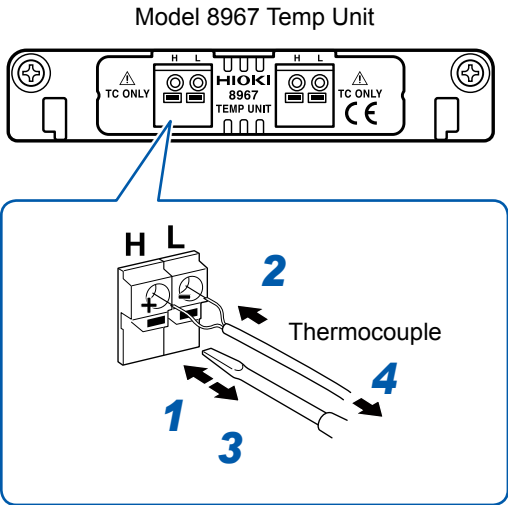

- 1** Depress a button on the terminal block on the module with the flat-blade screwdriver.
- 2** While depressing the button with the flat-blade screwdriver, insert each thermocouple wire into the appropriate terminal hole
- 3** Release the button.
The thermocouple is connected.
- 4** Attach the thermocouple on a measurement target.

How to disconnect the thermocouple

While depressing the button, pull the thermocouple wire.

- If noise influences surrounding equipment, pass the thermocouple element wires through the center hole of the ferrite clamp-on choke (comes with Model 8967 Temp Unit) several times successively from the same end.
- If a thermocouple three meters long or longer is connected, the measurement may be influenced by the EMC environment that includes external noise.
- For K type and E type thermocouples, the physical phenomenon, short-range ordering can probably cause incorrect temperature measurement in the range of 250°C to 600°C. Contact a thermocouple manufacturer to select proper thermocouples.

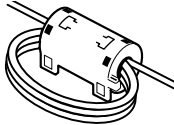

Strain gauge transducer

Connect a strain gauge transducer*¹ to Model U8969 Strain Unit via Model L9769 Conversion Cable*².

*1: Hioki does not offer any strain gauge transducers.

*2: Model L9769 Conversion Cable is an accessory of Model U8969 Strain Unit.

CAUTION



To prevent damage due to snapped wires, do not excessively bend, pull, or twist the cables and joints between the cables and connectors.

Required items: Strain gauge transducer and Model L9769 Conversion Cable

How to connect the transducer

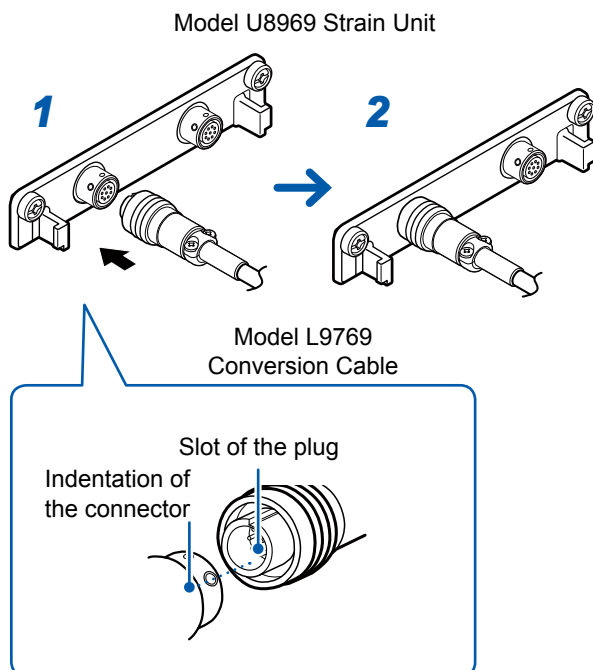

- 1** Align the plug slot of Model L9769 with the outward indentation of Model U8969, and then insert the plug into the connector on Model U8969.
- 2** Insert the plug until it locks.
- 3** Connect Model L9769 Conversion Cable to the strain gauge transducer.
- 4** Connect the strain gauge transducer to a measurement target.

How to disconnect the transducer

Gently pull the collar of the plug, which releases the lock, and disconnect the cable.

Connector pin-out

Model U8969 Strain Unit

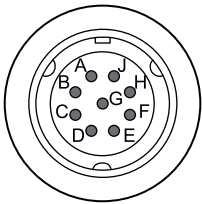

The metal shell is connected to the GND terminal of the instrument.

Model L9769 Conversion Cable
(Strain gauge converter)

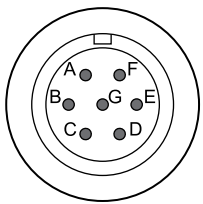

Applied voltage:
A bridge voltage of 2 V

The metal shell is connected to the GND terminal of the instrument.

Pin mark	Description
A	BRIDGE+
B	INPUT-
C	BRIDGE-
D	INPUT+
E	FLOATING COMMON
F	SENSE+
G	SENSE-
H	N.C.
J	N.C.

Pin mark	Description
A	BRIDGE+, SENSE+
B	INPUT-
C	BRIDGE-, SENSE-
D	INPUT+
E	FLOATING COMMON
F	N.C.
G	N.C.

Model L9769 connection

- Pin F of the conversion cable (module end) is connected to pin A of the conversion cable (transducer end).
- Pin G of the conversion cable (module end) is connected with pin C of the conversion cable (transducer end).

IMPORTANT

- A bridge box is required to measure strain using a strain gauge. Use a commercially available strain gauge and a bridge box.
- Some bridge boxes may be susceptible to noise. In that case, grounding the bridge box allows the box to be less susceptible to noise. For information about how to ground the bridge box, refer to the instruction of the bridge box or contact the manufacturer.

You can use your Model 8969 Strain Unit with the instrument. The instrument with Model 8969 Strain Unit installed refers to Model 8969 as **[U8969]** on the display.

Current sensor

Familiarize yourself with “Operation Precautions” (p. 8) before connecting a current sensor. Refer to the instruction manual that comes with each current sensor for details on specifications and directions for use.

CAUTION



Do not connect and remove a current sensor while the instrument is left turned on. Doing so will cause damage to the current sensor.

You can connect up to nine current sensors in total to the following modules: Model Z5021 Probe Power Unit, Model 8971 Current Unit, and Model U8977 3CH Current Unit.

Connectable current sensors

✓: Connectable with Model U8977; -: Conversion cable required

Model number	Model name	Maximum input current	Frequency	Directly connectable	Connector*1
9709	AC/DC Current Sensor	500 A	DC to 100 kHz	-*2	Plastic
9709-05				✓	Metal
9272-05	Clamp on Sensor	20 A / 200 A	1 Hz to 100 kHz	✓	Metal
9272-10				-*2	Plastic
CT6841	AC/DC Current Probe	20 A	DC to 1 MHz	-*2	Plastic
CT6841-05				✓	Metal
CT6843	AC/DC Current Probe	200 A	DC to 500 kHz	-*2	Plastic
CT6843-05				✓	Metal
CT6844	AC/DC Current Probe	500 A	DC to 200 kHz	-*2	Plastic
CT6844-05				✓	Metal
CT6845	AC/DC Current Probe	500 A	DC to 100 kHz	-*2	Plastic
CT6845-05				✓	Metal
CT6846	AC/DC Current Probe	1000 A	DC to 20 kHz	-*2	Plastic
CT6846-05				✓	Metal
CT6862	AC/DC Current Sensor	50 A	DC to 1 MHz	-*2	Plastic
CT6862-05				✓	Metal
CT6863	AC/DC Current Sensor	200 A	DC to 500 kHz	-*2	Plastic
CT6863-05				✓	Metal
CT6865	AC/DC Current Sensor	1000 A	DC to 20 kHz	-*2	Plastic
CT6865-05				✓	Metal
CT6875	AC/DC Current Sensor	500 A	DC to 500 kHz	✓	Metal
CT6876	AC/DC Current Sensor	1000 A	DC to 300 kHz	✓	Metal

*1: Metal connector (ME15W)
Plastic connector (PL23)

*2: The probe/sensor requires Model CT9900 Conversion Cable to connect with Model U8977 3CH Current Unit. The probe/sensor requires Model 9318 Conversion Cable to connect with Model 8971 Current Unit.

Connecting a current sensor with Model U8977 3CH Current Unit

You can directly connect a current sensor with the sub model-number “-05,” which has a metal connector (ME15W).

Point the widest key upward.

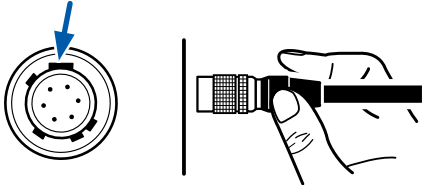

1 Align the guides of the cable connector with those of the module connector.

2 Straightly insert the connector until it locks.

Hold the part other than metal to insert the connector. The instrument automatically recognizes the model of the current sensor.

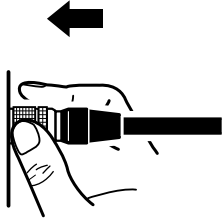

How to disconnect the current sensor

1 Hold and pull the metal collar, which releases the lock.

2 Pull the connector.

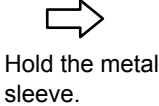

Using Model CT9900 Conversion Cable, you can connect a current sensor without the sub model-number “-05,” which has a plastic connector (PL23), with Model U8977 3CH Current Unit.

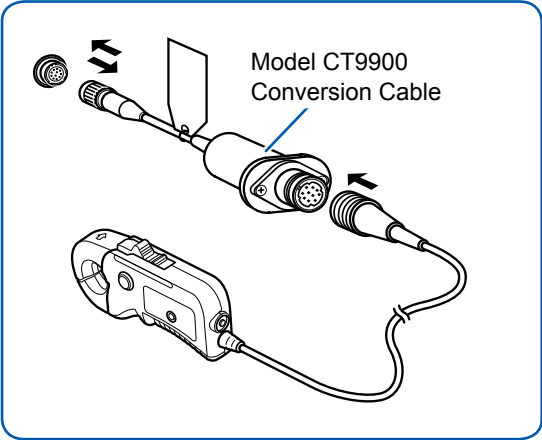

When Model CT9900 Conversion Cable is used, the instrument recognizes Model CT6846 or CT6865 (1000 A rating) as a 500-A AC/DC sensor. Set the conversion ratio to 2.00.

By using Model CT9920 Conversion Cable (optional), you can connect a current sensor of Model CT7000 series with Model U8977 3CH Current Unit. The instrument cannot recognize any sensor with Model CT9920 connected. Select a mode in the setting screen.

Applicable models: CT7631, CT7636, CT7642, CT7731, CT7736, CT7742, CT7044, CT7045, CT7046

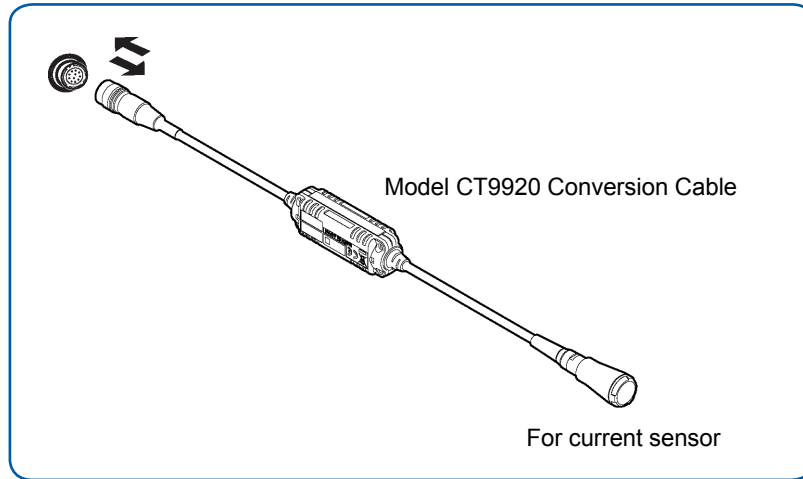

Connecting a current sensor with Model 8971 Current Unit

By using Model 9318 Conversion Cable*, you can connect a current sensor without the sub model number “-05,” which has a plastic connector (PL23), with Model 8971 Current Unit.

*: Model 9318 Conversion Cable is an accessory of Model 8971 Current Unit.

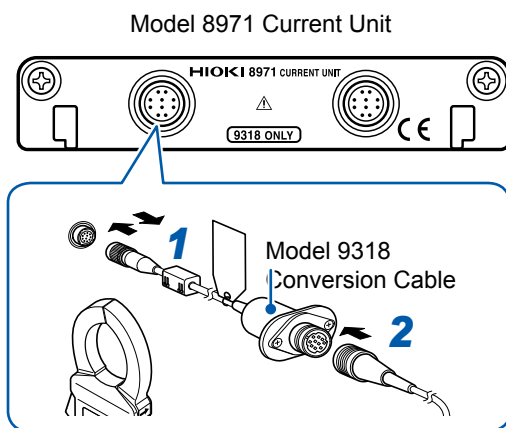

- 1** Align the guides of the conversion cable with those of the sensor connector on the module, and straightly insert the plug until it locks.
- 2** Align the guides of the current sensor to be used with those of the conversion cable connector, and straightly insert the plug until it locks.
The instrument automatically recognizes the model of the current sensor.
- 3** Clamp the current sensor around a line of a measurement target.

How to remove the current sensor

- 1** Hold and pull the plastic collar of the conversion cable, which releases the lock, and the remove the connector.
- 2** Hold and pull the plastic collar of the current sensor, which releases the lock, and the remove the connector.

When measuring currents with a voltage module

By using Model 9018-50 Clamp on Probe, you can measure a current using a voltage measurement module such as Model 8966 Analog Unit.

Specifying the scaling allows measured waveforms to be displayed as current values. For the setup procedure, refer to “Converting Input Values (Scaling Function)” of Instruction Manual.

Acceleration sensor

Connect a acceleration sensor to Model 8971 Current Unit.
Familiarize yourself with “Operation Precautions” (p. 8) before connecting a current sensor.

Acceleration sensor connectable with Model U8979

CAUTION



Use an acceleration sensor with a built-in pre-amplifier that conforms to the specification of Model U8979 Charge Unit. Using an inapplicable sensor may cause damaging itself.

Acceleration sensor type	Terminal the sensor is connected to	Note
Piezoelectric	BNC or miniature connector (Depending on sensor)	—
With a built-in pre-amplifier	BNC connector	Drive power: 3.5 mA, 22 V
Charge output	Miniature connector	—

*: Miniature connector terminal #10-32

Connecting an acceleration sensor with a built-in pre-amplifier

Connecting a BNC-output acceleration sensor with a built-in pre-amplifier

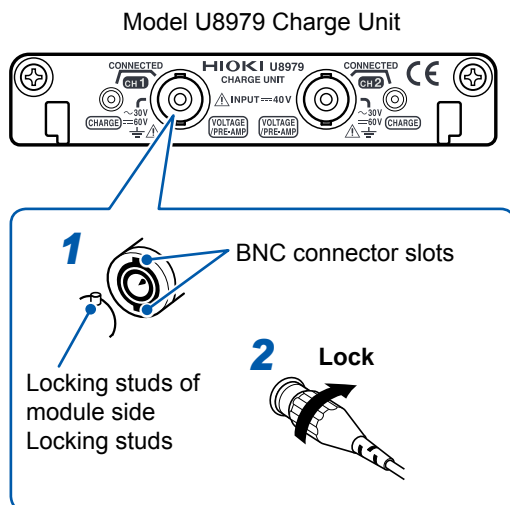

- 1** Align the slots in the BNC connector of an acceleration sensor with the locking studs of a BNC connector on the module, and insert the connector.
- 2** Turn the BNC connector of the acceleration sensor clockwise until it locks.
- 3** Attach the acceleration sensor with the built-in pre-amplifier to a measurement target.

How to remove the acceleration sensor

Turn the BNC connector of the acceleration sensor counter-clockwise to release the lock and remove the connector.

Connecting an acceleration sensor other than a sensor with a built-in pre-amplifier

Convert the output connector into the BNC connector using a commercially available conversion connector or conversion cable to connect the sensor.

Connecting a charge-output acceleration sensor

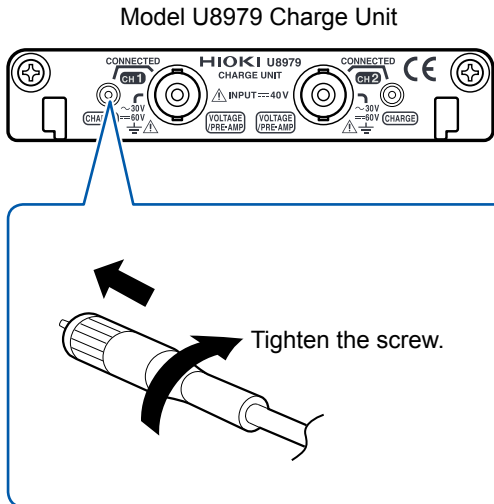

- 1** Align the screw of the miniature connector, and turn the connector clockwise to tighten it.
- 2** Attach the charge-output acceleration sensor to a measurement target.

How to disconnect the current sensor

Turn the miniature connector counterclockwise, and then pull out the connector.

Connecting an charge-output acceleration sensor equipped with a connector other than a miniature connector (#10-32)

Convert the output connector into the miniature connector (#10-32) using a commercially available conversion connector or conversion cable to connect the sensor.

Logic probe (Measuring logic signals)

Connect logic probes to Model 8973 Logic Unit.
Refer to "Before connecting a logic probe to a measurement target" (p. 15).
Refer to an instruction manual of each logic probe.

Required item: Logic Probe (Model 9320-01, Model MR9321-01, or Model 9327)

How to connect the Logic Probe

Example: Connecting Model 9327 Logic Probe

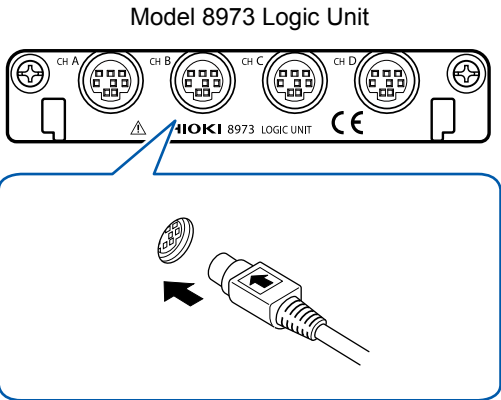

- 1 Align the plug slots of the logic probe with a logic terminal, and insert the logic probe plug.
- 2 Connect the logic probe to a measurement target.

2 Preparing for Measurement

Connection cable (For precisely measuring voltage)

Connect Model L2200 Test Lead to a module.

Required item: Model L2200 Test Lead (maximum input voltage: 1000 V)

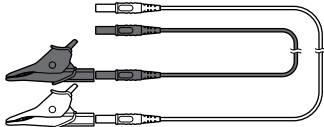

How to connect the Test Lead

Model MR8990 Digital Voltmeter Unit

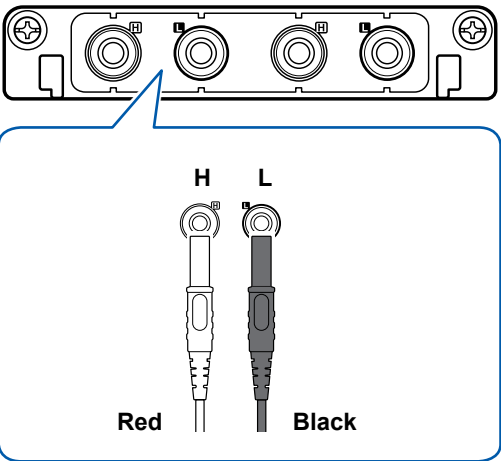



- 1 Connect the test leads to the banana jacks on the module.
Connect the black lead to the L jack; and the red lead to the H jack. Make sure the test leads are fully inserted into the jacks.
- 2 Connect the test leads to a measurement target.

Connection cable (for measuring high voltage)

Connect Model L4940 Connection Cable Set to Model U8974 High Voltage Unit. Choose appropriate connection cord tips based on the maximum input voltage and terminal type.

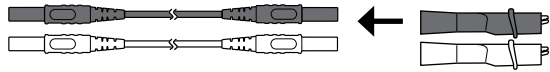
Required item: Model L4940 Connection Cable Set

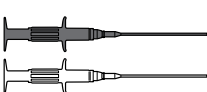
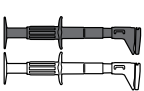
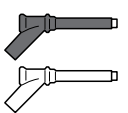
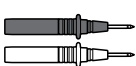
	Model L4934* Small Alligator Clip Set	CAT III 300 V CAT II 600 V
	Model L4935 Alligator Clip Set	CAT III 1000 V CAT IV 600 V
		
	Model 9243 Grabber Clip	CAT III 1000 V
	Model L4936 Bus Bar Clip Set	CAT III 600 V
	Model L4937 Magnetic Adapter Set	CAT III 1000 V
	Model L4932 Test Pin Set	CAT III 1000 V CAT IV 600 V

* Using Model L4934 requires Model L4932.

How to connect the thermocouple

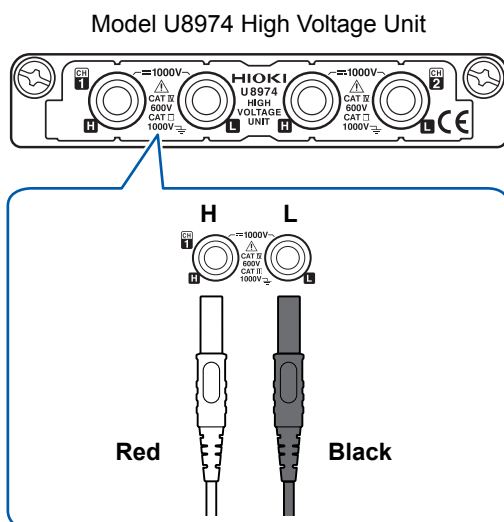

- 1** Connect the plugs of the connection cord to the banana jacks on the module.
Connect the plugs to the banana jacks of their respective colors.
- 2** Insert the accessory clips into the clip ends of the connection cord.
- 3** Connect the connection cord clips to a measurement target.

2.3 Supplying Power to Current Sensors

Model Z5021 Probe Power Unit (option available only at the time of purchase order issuance for the instrument) allows the instrument to supply power to current sensors.

The instrument can supply power to up to nine current sensors through Model 8971 Current Unit and Model U8977 3CH Current Unit.

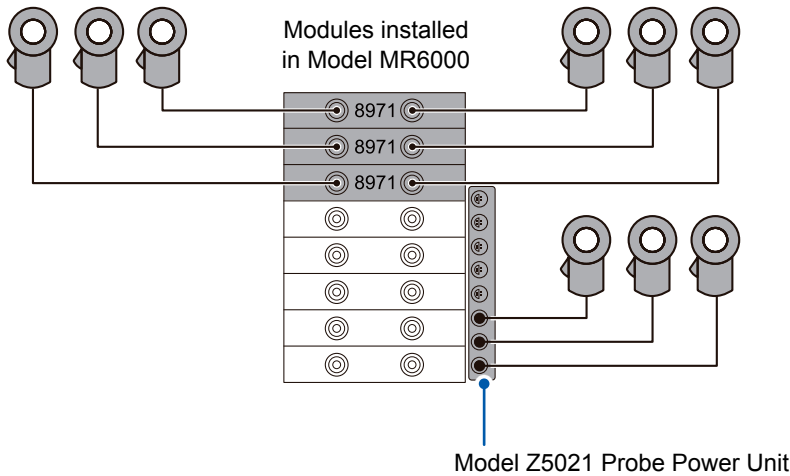

2
Preparing for Measurement

How to connect a current sensor

Insert the power plug of the current sensor into the power terminal dedicated to current sensors.

⚠ CAUTION



You may not be able to connect a connection cord to channels adjacent to a module that has a BNC connector with a current probe connected to because the termination unit interferes with adjacent channels. Attempting to forcedly insert a connection cord could cause damage to the connectors of the current sensor and module, as well as the instrument. For resolving this problem, a conversion cable is available on a special order basis. Contact your authorized Hioki distributor or reseller.

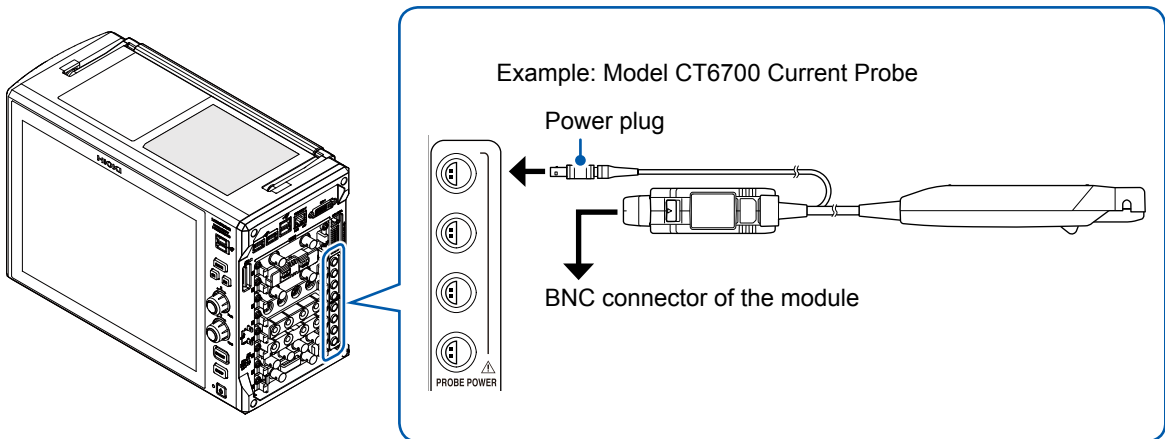

2.4 External Sampling (EXT.SMPL)

Externally inputting the signal can control the sampling rate.
 Refer to “Before connecting the instrument to external equipment” (p. 16).

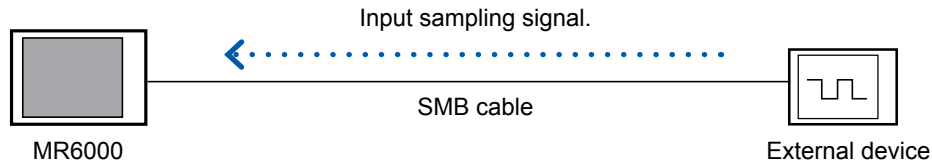

How to connect the external device

Connect the external sampling terminal of the instrument and the external device (sampling signal source) with each other using an SMB cable. Connect the connector of the SMB cable* to the external sampling terminal until it clicks.

*: Use one of the following cables:

Model L9795-01 Connection Cable (terminal type: SMB terminal–alligator clip, optional)

Model L9795-02 Connection Cable (terminal type: SMB terminal–BNC terminal, optional)

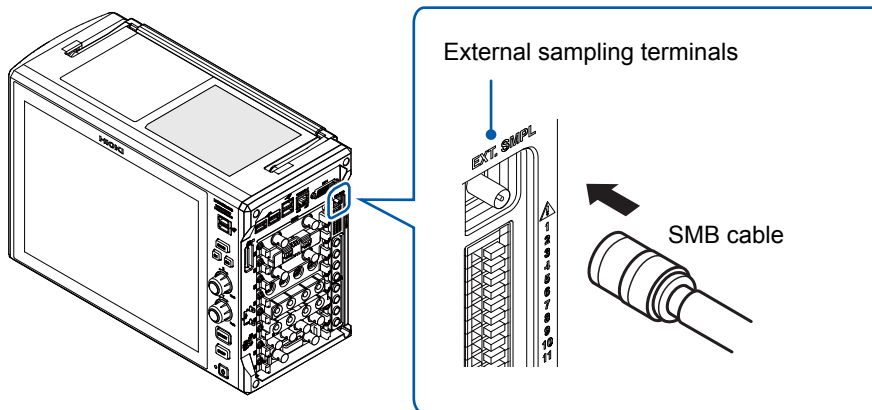

How to remove the external device

Hold the head of the SMB connector (other than the cable) and pull it out.

How to configure the external sampling terminal settings

Refer to “13.2 External Sampling (EXT.SMPL)” of Instruction Manual.

2.5 Connecting the External Control Terminals

This section describes the procedure and the external control terminal function to control the instrument externally. Connecting the external control terminals with external devices allows the instrument to start and stop a measurement. Signals inputted into the external control terminals operate the instrument even when the key lock function is enabled.

The term “external control terminals” is used to refer to all of these terminals collectively. Refer to “Before connecting the instrument to external equipment” (p. 16).

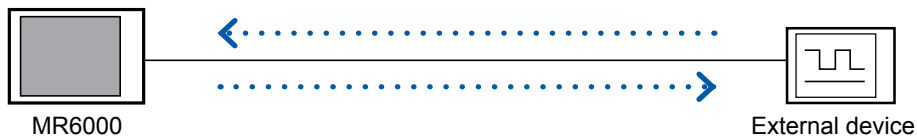

Wires to be connected

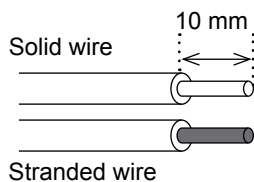

Recommended wire	Solid wire 0.65 mm in diameter (AWG22) Stranded wire 0.32 mm ² (AWG22)
Acceptable wire	Solid wire 0.32 mm to 0.65 mm in diameter (AWG28 to AWG22) Stranded wire 0.08 mm ² to 0.32 mm ² (AWG28 to AWG22) Strand diameter 0.12 mm or more (per wire)
Stripped length	9 mm to 10 mm
Button pressing tool	Flat-blade screwdriver (shaft diameter: 3 mm, tip width: 2.6 mm)

How to connect wires

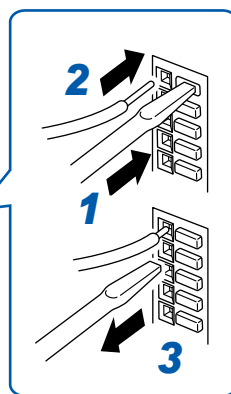
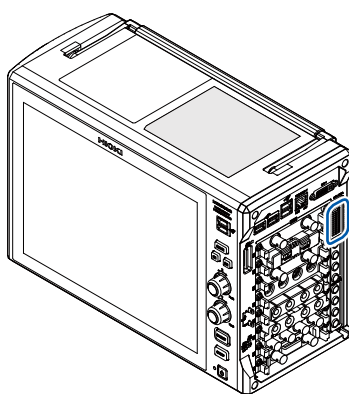

- 1** Depress the terminal button using a tool, such as a flat-blade screwdriver.
- 2** Insert the wire into the wire connection hole while depressing the button.
- 3** Release the button.
The wire is locked.

Terminal block

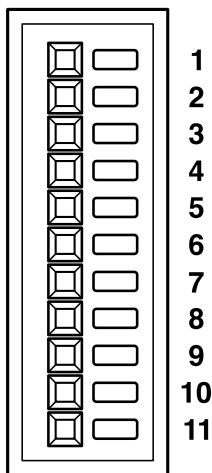

No.	Pin name	Operation
1	GND	–
2	IN1	Starts/stops measurement, saves data files, aborts measurement, enters events
3	IN2	
4	GND	–
5	OUT1	Outputs signals indicating judgments and status (error, busy, waiting for a trigger)
6	OUT2	
7	GND	–
8	EXT.TRIG	The instrument is triggered when an external signal is inputted as a trigger source.
9	TRIG.OUT	Outputs a signal when the instrument is triggered.
10	GND	–
11	GND	–

How to configure the external control terminal settings

On the **[External terminal]** screen, you can configure the following terminal: the external input (IN1, IN2), external output (OUT1, OUT2), and trigger output (TRIG.OUT). Use the **[Trigger]** screen to configure the external trigger (EXT.TRIG) setting.

 > **[System]** > **[External terminal]**

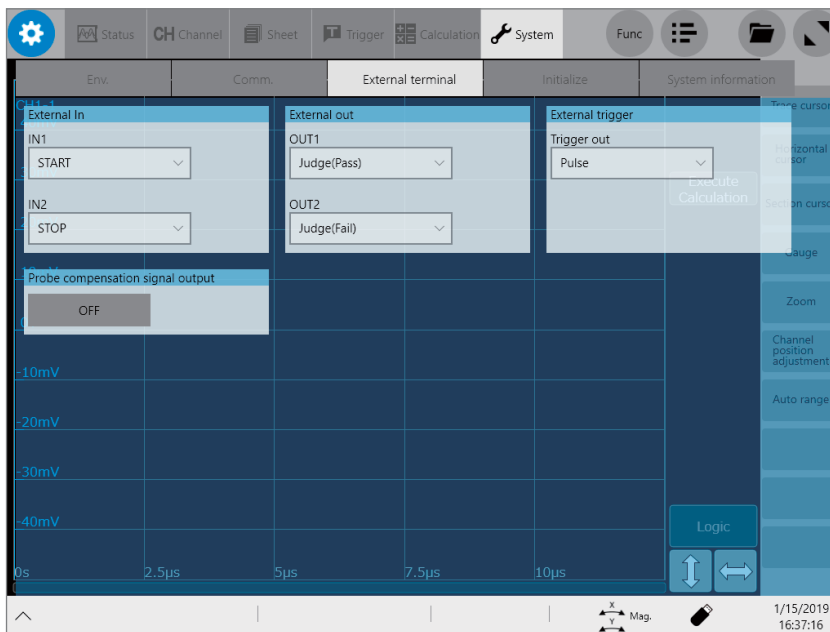

2.6 Connecting the Instrument With Computers

Connecting the instruments with computers via a LAN cable allows computers to control and monitor the instrument. Connect LAN cables to the 1000BASE-T connector of computers and instrument.

⚠ CAUTION



When connecting the instrument to your LAN using a LAN cable of more than 30 m or with a cable laid outdoors, take appropriate countermeasures that include installing a surge protector for LANs. Such signal wiring is susceptible to induced lightning, which can cause damage to the instrument.

The following two ways are available:

(1) Connecting the instrument to the existing network

Connecting the instruments with a hub via LAN cables allows computers to control and monitor the instruments.

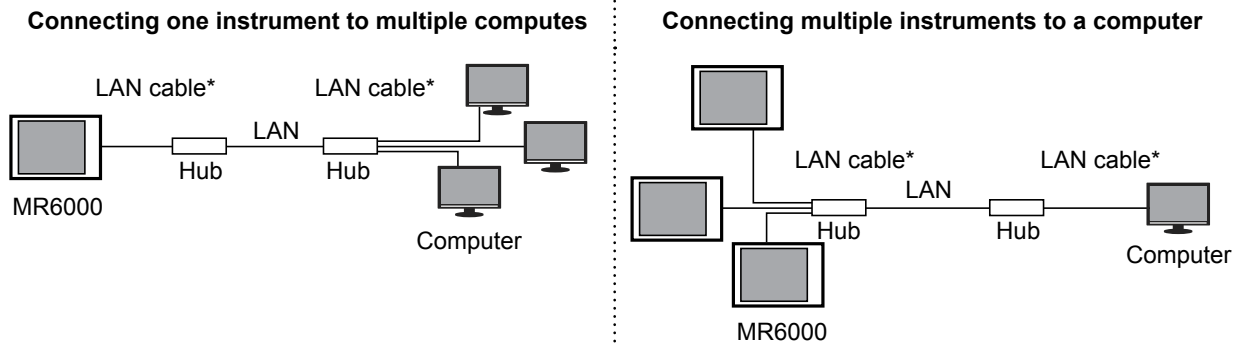

*: Use one of the following cables:

- 1000BASE-T straight-through cable (maximum length: 100 m, commercially available)
- Model 9642 LAN Cable (optional)

(2) One-to-one connection of the instrument and your computer

Connecting the instrument with your computer via a LAN cable allows the computer to control and monitor the instrument.

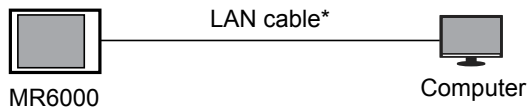

*: Use one of the following cables:

- 1000BASE-TX compatible crossover cable (maximum length: 100 m)
- 1000BASE-T straight-through cable and crossover connector (maximum length: 100 m)
- Model 9642 LAN Cable (optional, coming with crossover connector)

When connecting the instrument and the computer using Model 9642 LAN Cable and the accompanying crossover connector

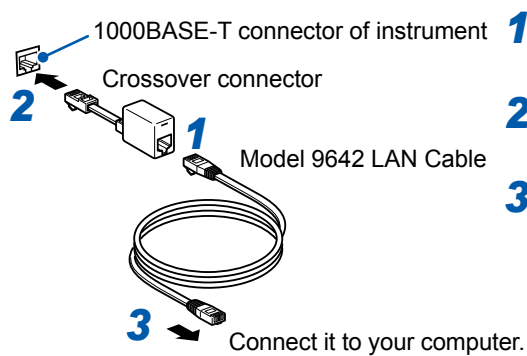

- 1** Connect Model 9642 LAN Cable to the accompanying crossover connector.
- 2** Connect the crossover connector to the 1000BASE-T connector of the instrument.
- 3** Connect Model 9642 LAN Cable to the 1000BASE-T connector of your computer.

2.7 Preparing Storage Devices (Recording Media)

You can use the following recording media on the instrument: SD memory cards, USB flash drives, and a built-in drive.
 Refer to “Handling storage devices” (p. 13).

SD memory card

You have to configure the SD memory card setting on the instrument to use SD memory cards.
 Refer to “Formatting storage devices” (p. 61).

How to insert a USB flash drive

- 1** Orient the face with triangle marked of the SD memory card toward the front of the instrument.
- 2** Fully insert the SD memory card.

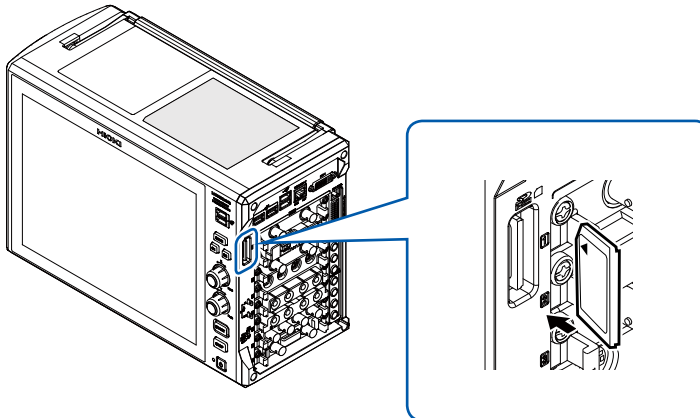

USB flash drive

The instrument supports not all commercially available USB flash drives. You have to configure the USB flash drive setting on the instrument to use USB flash drives.
 Refer to “Formatting storage devices” (p. 61).

How to insert a USB flash drive

Align the USB flash drive with the connector, and fully insert it.

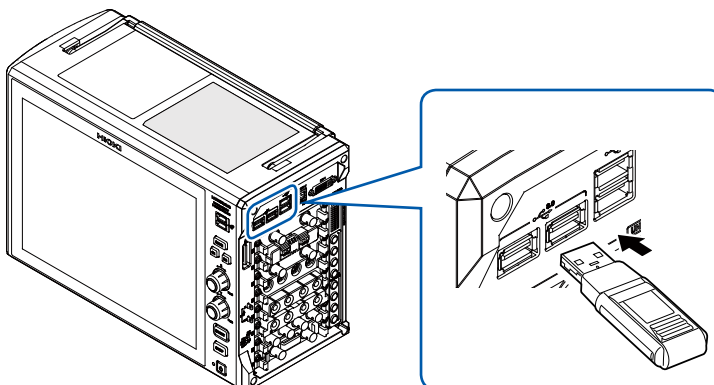

Built-in drive

The built-in drive is factory-formatted.

Model U8332 SSD Unit (capacity: 256 GB*, option available only at the time of purchase order issuance for the instrument)

Model U8333 HD Unit (capacity: 320 GB*, option available only at the time of purchase order issuance for the instrument)

*: Once the drive has been formatted, the actual capacity available decreases.

You cannot remove the built-in drive.

Removing storage devices

Use the following procedure to remove the SD memory card and USB flash drive.

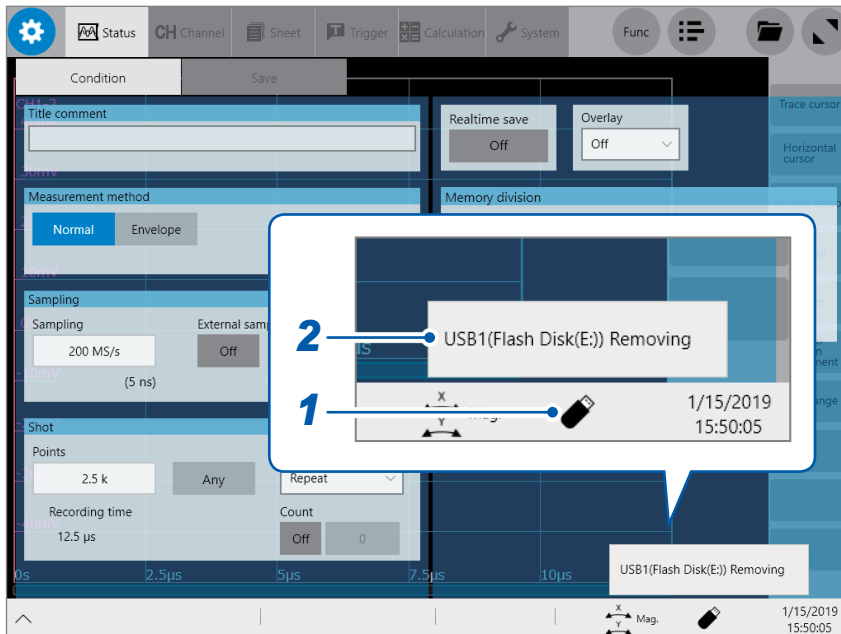

- 1** Tap the remove button.
- 2** Tap the media to be removed.
- 3** Remove the storage device according to the message.

This device can be removed.	Remove the storage device.
This device cannot be removed.	Check whether the storage device is being accessed.

Be sure to use the remove button to remove any storage device. Do not use Windows® Explorer or an icon on the Windows® taskbar to remove the storage device.

Formatting storage devices

The instrument can format SD cards, USB flash drives, and the built-in drive. Once they are formatted, the “HIOKI_MR6000” folder is created.

IMPORTANT

Note that formatting a storage device deletes all the information stored on the storage device, and deleted information cannot be recovered.

 > [Func] > [Explorer]

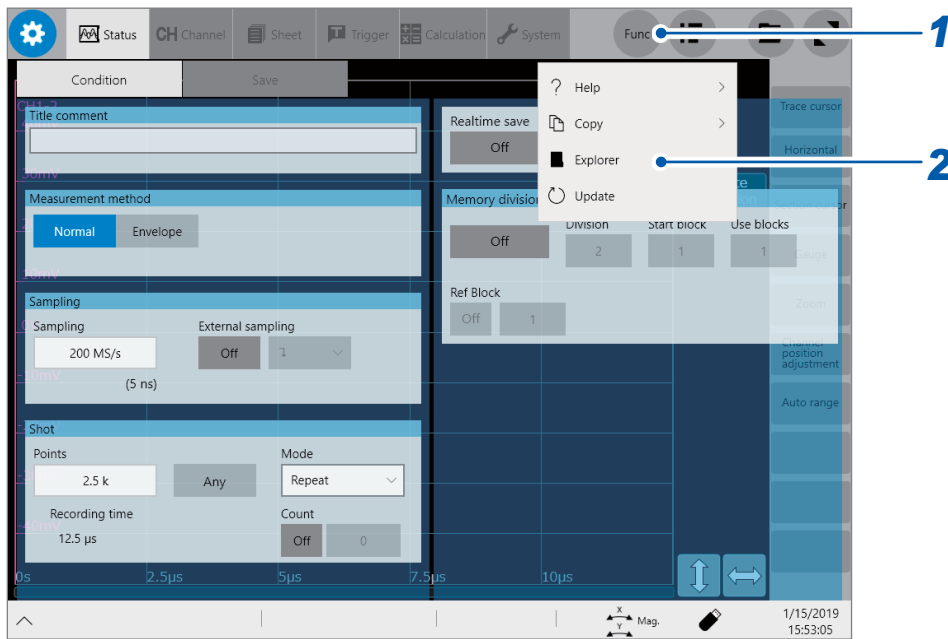

- 1** Tap [Func].
- 2** Tap [Explorer].
Explorer appears.
- 3** Touch and hold a storage device to be formatted for 2 seconds.
The shortcut menu appears
- 4** Tap [Format].

2.8 How to Open the Media Box

The USB3.0 port in the media box is dedicated to USB flash drives.

Be sure to use the instrument with the cover closed. Before handling a USB flash drive, eliminate any static on your body.

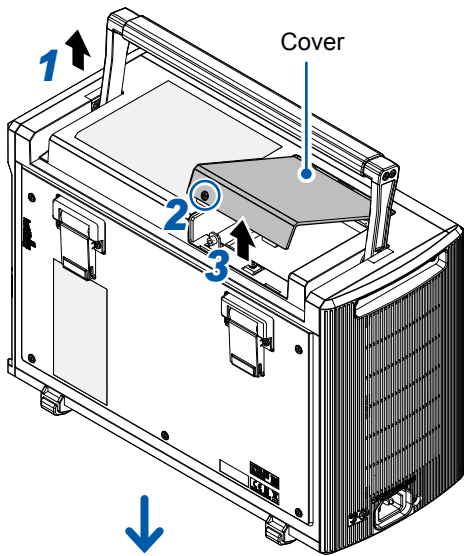

- 1** Extend the handle.
- 2** Loosen the cover screw until its head is completely removed from the cover.
- 3** Lift the front of the cover.

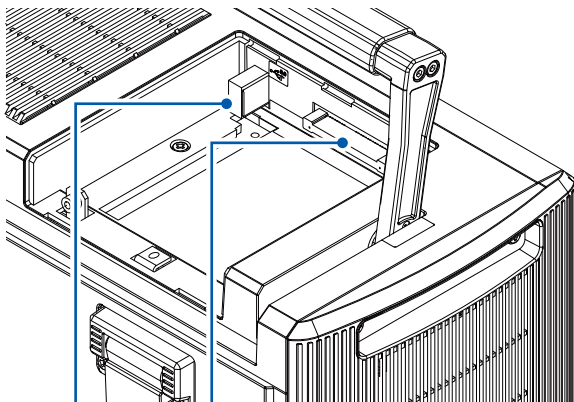

USB 3.0 connector

Connector for SSD/HD unit

2.9 Supplying Power to the Instrument

Refer to “Before turning on the instrument” (p. 15).

Turning on the instrument

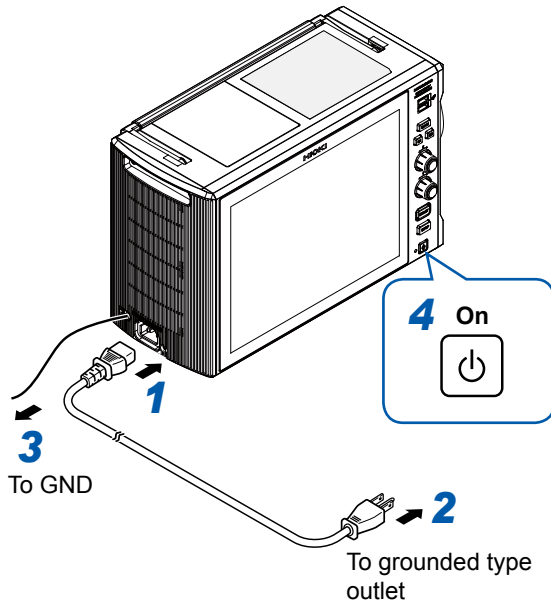

- 1** Connect the power cord to the power inlet on the instrument.
- 2** Connect the plug to a grounded type outlet.
- 3** Connect the GND terminal (functional earth terminal) to the earth.
- 4** Press the power key to turn on the instrument.
The splash screen appears, and then the waveform screen appears.
- 5** Warm up the instrument for about 30 minutes.
This warm-up stabilizes the temperature in the modules, yielding accurate measurement.
- 6** Execute zero-adjustment.
Refer to “2.11 Executing Zero-Adjustment” (p. 65).
- 7** Start a measurement.
Refer to “3.5 Starting/Stopping a Measurement” (p. 77).

2

Preparing for Measurement

GND terminal (functional earth terminal)

If you perform measurement in a noisy environment, connecting the GND terminal (functional earth terminal) to the earth allows the instrument to be less susceptible to noise.

Turning off the instrument

IMPORTANT

Turning off the instrument causes data recorded in the internal memory to be deleted. To retain the recorded data, save the data to an external storage device before turning off the instrument. Refer to “3.6 Saving Data Consisting of Items Selected” (p. 78).

- 1** Save the acquired data if needed.

- 2** Press the power key.

Following the message, tap **[OK]** to turn off the instrument. Alternatively, pressing the power key once again turns off the instrument. After the instrument has been turned on again, it loads the settings configured before turned off.

2.10 Setting the Clock

Specify the date, time, and time zone. The instrument has the automatic calendar with leap year correction and 24-hour clock.

 > [System] > [Env.]

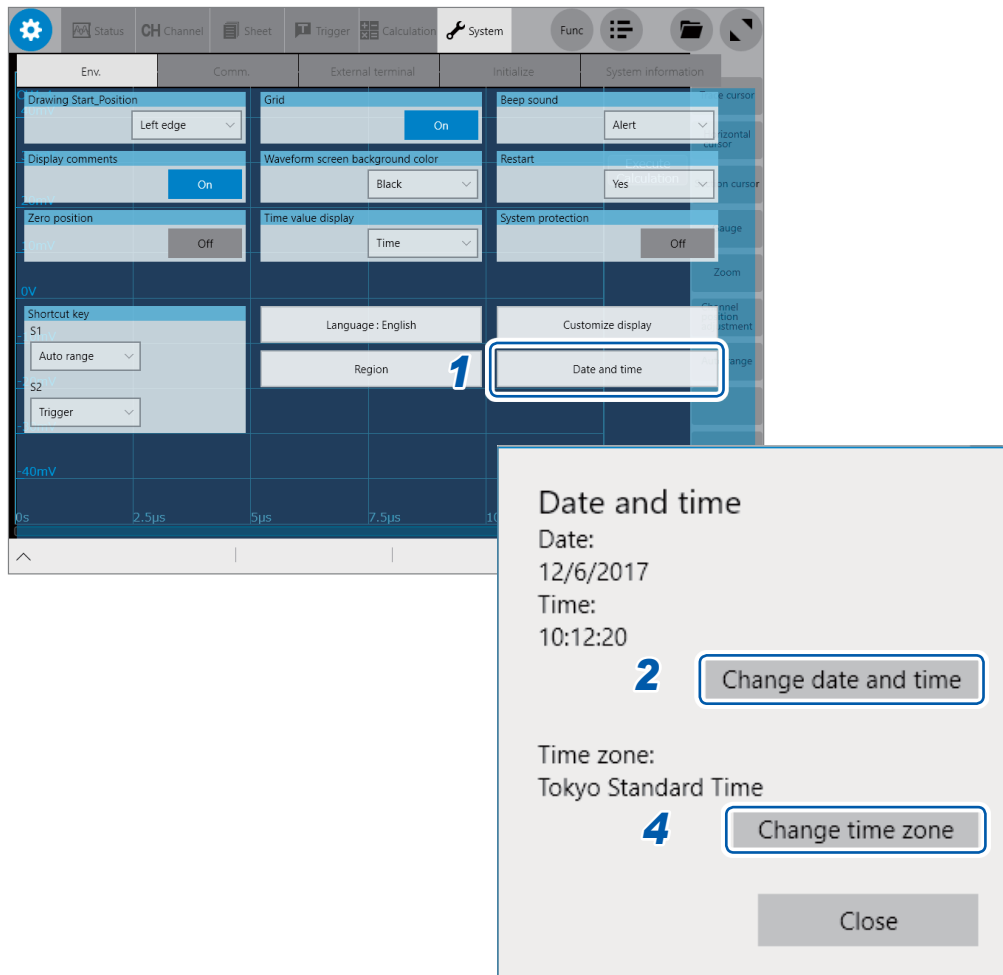

- 1** Tap [Date and time].
The [Date and time] dialog box will appear.
- 2** Tap [Change date and time].
- 3** Set the date and time and then tap [OK].
- 4** Tap [Change time zone].
- 5** Select a time zone in the list of the [Time zone] box and then tap [OK].
The application re-launches.

IMPORTANT

Do not change any Windows® setting unless otherwise indicated in this document.

Doing so may cause unstable system operation.

The instrument regulates the clock internally. Always select  > [System] > [Env.], and then tap [Date and time] to set the clock. In other ways besides, the clock could not be set.

2.11 Executing Zero-Adjustment

Executing zero-adjustment regulates the zero positions of all channels in each module on the reference potential of the instrument. Zero-adjustment involves all ranges of all channels.

Before executing zero-adjustment

- Warm up the instrument for about 30 minutes after the power-on to stabilize the internal temperature of the modules, and then execute zero-adjustment.
- Execute zero-adjustment with no signals inputted. Zero-adjustment may not correctly be executed with a signal inputted.
- Note that you can not execute zero-adjustment during measurement.
- No key operation is acceptable during zero-adjustment.
- The time required for zero-adjustment varies depending on the type and number of modules installed in the instrument (In some cases, it takes several seconds.).

To execute zero-adjustment

 > [Channel] > each module (UNIT)

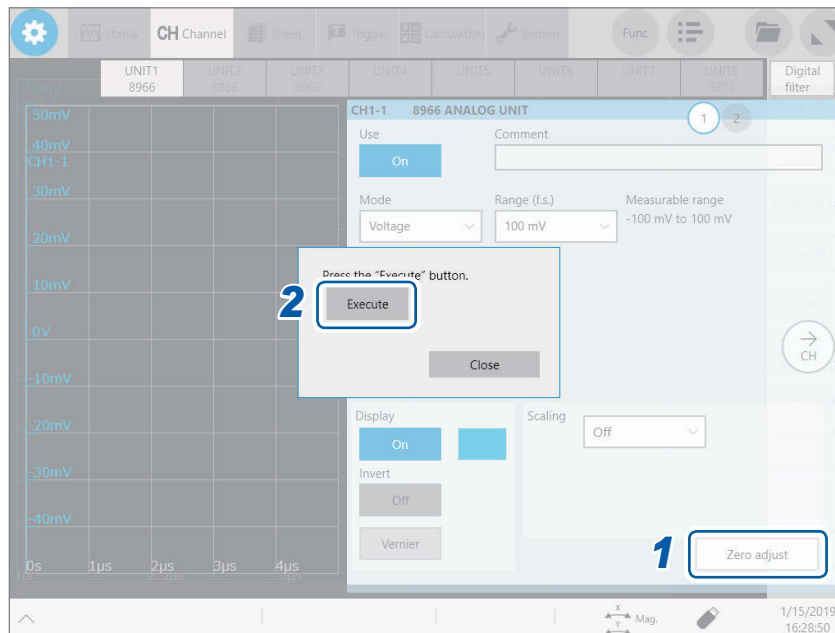

1 Tap [Zero adjust].

2 Tap [Execute].

The instrument performs zero-adjustment.

You cannot regulate the zero position of Model U8969 by this method. Regulate the zero position using the auto-balance.

Refer to “Model U8969 Strain Unit” (p. 112).

Refer to “Settings of the Model U8969 Strain Unit” in “3.6 Configuring Module-Specific Settings” of Instruction Manual.

Re-execute zero-adjustment in the following cases:

- After replacing any modules
- After cycling the instrument
- After initializing the instrument
- After switching between DC mode and RMS mode on Model 8971 Current Unit, Model 8972 DC/RMS Unit, or Model U8974 High Voltage Unit.
- When the ambient temperature has significantly changed
The zero position may drift*.

*: Drift:

A phenomenon where a shift in the operating point of an operational amplifier causes a false output. Drift can result from a change in temperature and component aging over a period of use.

2.12 Executing Calibration (For the Instrument With Model MR8990 Installed)

Executing calibration regulates the zero position of each channel in Model MR8990 Digital Voltmeter Unit on the reference potential of the instrument. Calibration involves all ranges of all channels.

Before executing calibration

- Warm up the instrument for about 30 minutes after the power-on to stabilize the internal temperature of the modules before executing calibration.
- You cannot execute calibration during measurement. However, the instrument performs calibration at the start of measurement with the calibration setting set to on.
- No key operation is acceptable during calibration.
- The time required for calibration varies depending on the type and number of modules installed in the instrument (it may take several seconds).

Executing calibration

 > [Channel] > [MR8990]

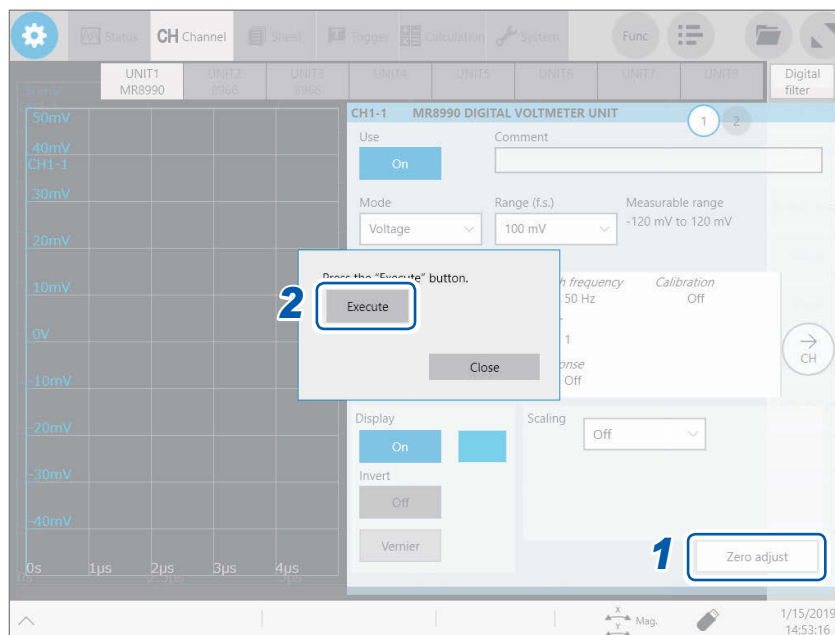

1 Tap [Zero adjust].

2 Tap [Execute].

The instrument starts calibration.

Re-execute calibration in the following cases:

- After replacing any modules
- After cycling the instrument
- After initializing the instrument
- When the ambient temperature has significantly changed
The zero position may drift.

3

Measurement Method

3.1 Inspection Before Measurement

Check if there is any damage to the instrument occurred during storage or shipping and verify that it operates normally before using the instrument. If you find any damage, contact your authorized Hioki distributor or reseller.

Inspecting peripheral devices

When using probes and connecting cords

Is the insulation of each probe of each cord damaged?
Is the metal part exposed?

Yes

Do not use them because it may cause an electric shock. Send them for repair.

No

When using a current sensor

Does the current sensor (jaw) have cracks or damage?

Yes

Do not use them because it may cause an electric shock. Send them for repair.

No

Inspecting the instrument and modules

Are the instrument and modules damaged?

Yes

Send them for repair.

No

When turning on the instrument

Does the screen display the logo "HIOKI"?

No

The power cord may have a brake or the internal circuit of the instrument may have failed. Send the instrument for repair.

Yes

The screen displays nothing or something abnormal.

Does the screen display waveforms?

Yes

The instrument may have an anomaly inside. Send the instrument for repair.

Yes

The inspection is completed.

3.2 Setting Measurement Conditions

Set conditions required for measurement, such as the sampling rate and recording length.

 > [Status] > [Condition]

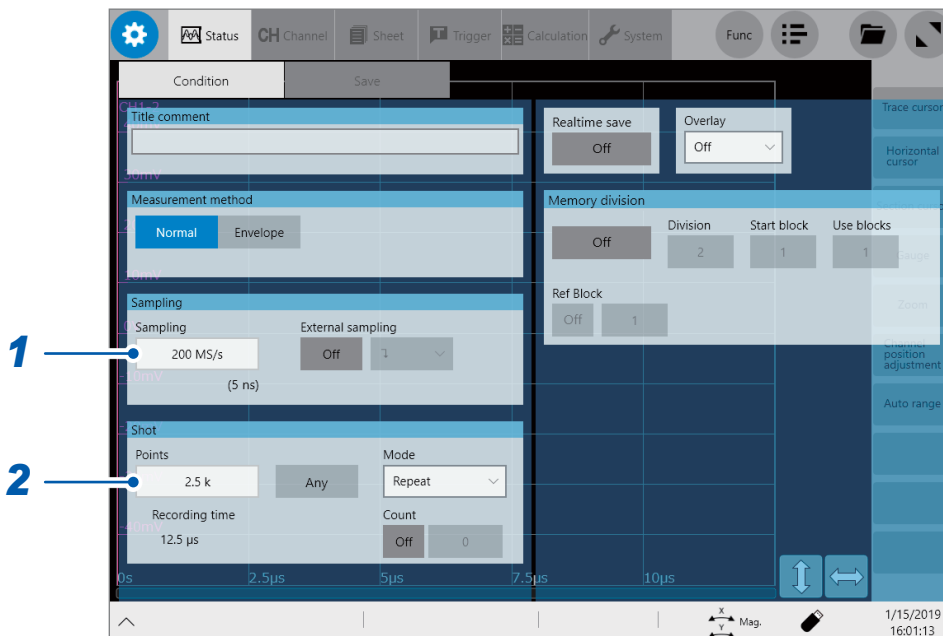

1 Tap the [Sampling] box, and then choose a sampling rate from the list.

Refer to “Sampling rate setting guideline” (p. 71).

200 MS/s , 100 MS/s, 50 MS/s, 20 MS/s, 10 MS/s, 5 MS/s, 2 MS/s, 1 MS/s,
500 kS/s, 200 kS/s, 100 kS/s, 50 kS/s, 20 kS/s, 10 kS/s, 5 kS/s, 2 kS/s, 1 kS/s,
500 S/s, 200 S/s, 100 S/s, 50 S/s, 20 S/s, 10 S/s, 5 S/s, 2 S/s, 1 S/s

The instrument can measure signals at a sampling rate of 200 MS/s even with several modules other than Model U8976 installed together. However, the data update rate does not exceed the maximum sampling rate of each module.

2 In the [Shot] area, tap the [Points] box, and then choose an option for the number of points to be measured from the list.

2.5 k , 5 k, 10 k, 20 k, 50 k, 100 k, 200 k, 500 k, 1 M, 2 M, 5 M, 10 M, 20 M, 50 M, 100 M, 200 M,
500 M, 1 G

Sampling rate setting guideline

Choose a sampling rate using the following table as a guideline.

Maximum display frequency	Sampling rate	Maximum display frequency	Sampling rate
8 MHz	200 MS/s	400 Hz	10 kS/s
4 MHz	100 MS/s	200 Hz	5 kS/s
2 MHz	50 MS/s	80 Hz	2 kS/s
800 kHz	20 MS/s	40 Hz	1 kS/s
400 kHz	10 MS/s	20 Hz	500 S/s
200 kHz	5 MS/s	8 Hz	200 S/s
80 kHz	2 MS/s	4 Hz	100 S/s
40 kHz	1 MS/s	2 Hz	50 S/s
20 kHz	500 kS/s	0.8 Hz	20 S/s
8 kHz	200 kS/s	0.4 Hz	10 S/s
4 kHz	100 kS/s	0.2 Hz	5 S/s
2 kHz	50 kS/s	0.08 Hz	2 S/s
800 Hz	20 kS/s	0.04 Hz	1 S/s

If the instrument plots false waveforms (aliasing)

If a measured signal oscillates at a higher frequency compared to the sampling rate you chose, the instrument may plot a false waveform oscillating at a frequency lower than that of the actual signal once the signal frequency reaches a certain level. This phenomenon is called aliasing.

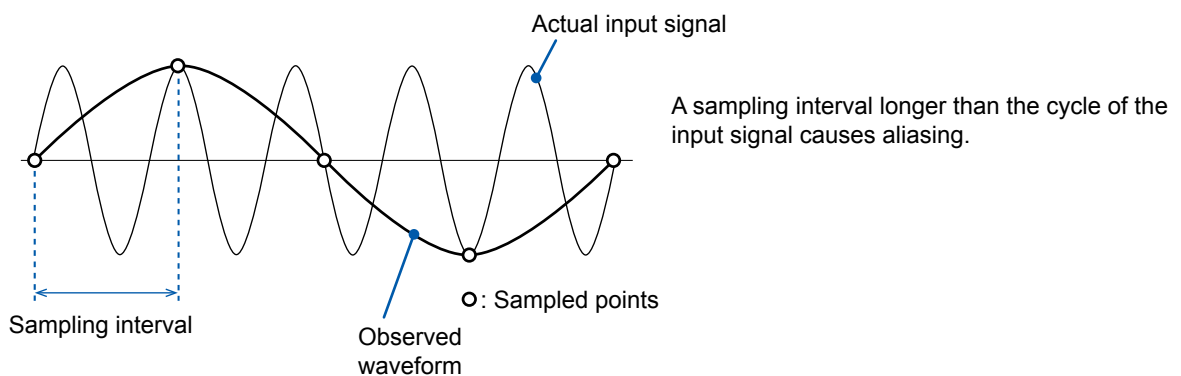

To plot a sign wave that allows you to observe the peaks without any aliasing, the instrument needs to sample the waveform at a minimum of 25 points per cycle.

To set the sampling rate automatically

Refer to “3.7 Measuring Signals With the Auto-range Setting” (p. 81).

3.3 Configuring the Input Channel settings

Configure the analog channel settings.

How to configure the channel settings

This section describes how to configure the analog channel (CH1-1 through CH8-4) settings. For details of analog channels such as a setting of each module, refer to “1.3 Configuring the Input Channel Settings” of Instruction Manual.

Configuring the input settings

Choose a measurement mode.

Choose an appropriate range for measurement target.

Choose an input coupling method.

Configure the low-pass filter settings (for measurement in a noisy environment).

Configure each module settings (as required).

Configuring the display settings

Choose a waveform display color.

Choose a display position and magnification ratio (as required).

Fine-adjust waveform amplitude. (vernier function)

Convert input values. (scaling function)

Specifying the trigger settings (as required)

Configure the level trigger settings.

- When the input coupling method is set to GND, the instrument measures the ground potential in the module; thus, it does not measure any input waveforms.
- An influence of the filter attenuation may prevent the instrument from choosing an appropriate range.

Analog channel

 > [Channel] > each module (UNIT)

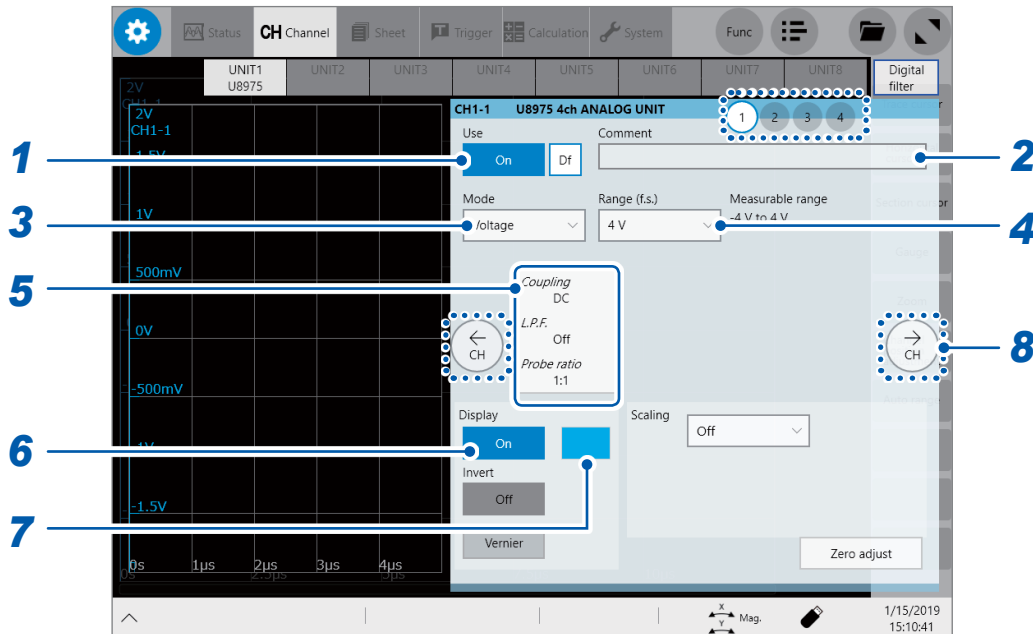

1 Tap the [Use] button to set it to [On] or [Off].

On <input checked="" type="checkbox"/>	Measures a waveform through this module.
Off <input type="checkbox"/>	Does not measure any waveform through this module. Since no data is acquired, the instrument displays or saves nothing.

2 Enter a comment in the [Comment] box.
Number of characters that can be entered: up to 40

3 Tap the [Mode] box, and then choose a measurement mode from the list.

Voltage <input checked="" type="checkbox"/>	Measures a waveform in voltage mode.
Temperature <input type="checkbox"/>	Measures a waveform in temperature mode.

Selectable modes vary depending on the installed modules.
Refer to “3.6 Configuring Module-Specific Settings” of Instruction Manual.

4 Tap the [Range (f.s.)] box, and then choose a measurement range from the list.

The measurement ranges that can be chosen varies depending on modules.
If an input voltage exceeds the measurable range (overrange), change the measurement range to one with a lower sensitivity.

5 Specify the cutoff frequency of the low-pass filter and the probe ratio in [L.P.F] and [Probe ratio], respectively.

Tapping the area that includes [L.P.F] and [Probe ratio] allows the setting dialog box to appear.

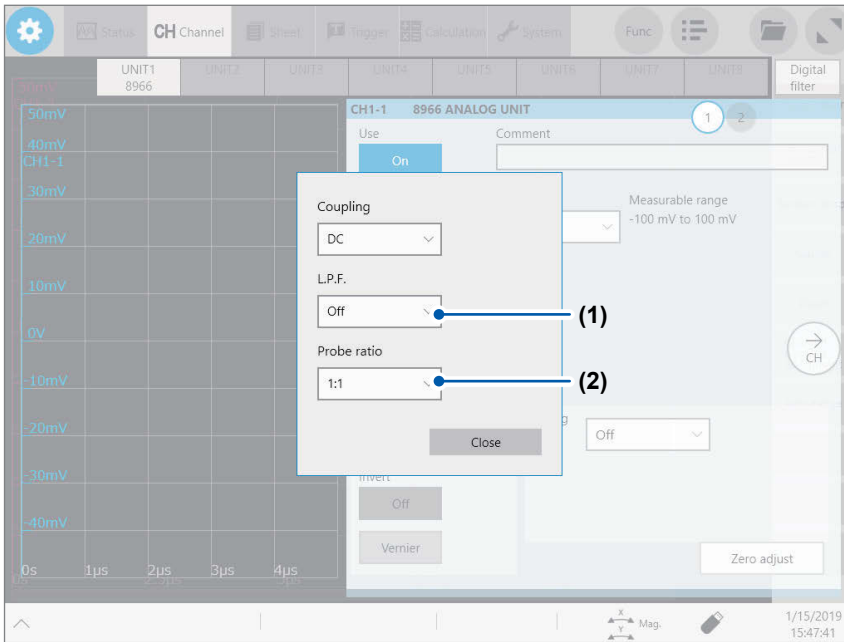

(1) Tap the [L.P.F] box, and then choose a cutoff frequency of the low-pass filter from the list.

Enabling the low-pass filter in the module eliminates excessive harmonic components. Available cutoff frequencies of the low-pass filter vary depending on the module type. Choose an adequate cutoff frequency depending on the characteristics of an input signal.
Example: Model 8966 Analog Unit

Off, 5 Hz, 50 Hz, 500 Hz, 5 kHz, 50 kHz, 500 kHz

(2) Tap the [Probe ratio] box, and then choose a probe ratio from the list.

Configure this setting when you perform measurement using the instrument with connection cords or probes connected.

1:1	Choose this option when using any of the following cords: <ul style="list-style-type: none"> • Model L9197 Connection Cord • Model L9790 Connection Cord • Model L9198 Connection Cord • Model L9217 Connection Cord
1:10	Choose this option when using Model 9665 10:1 Probe.
1:100	Choose this option when using Model 9666 100:1 Probe, Model P9000-01 Differential Probe, or Model P9000-02 Differential Probe.
1:1000	Choose this option when using Model 9322, Model P9000-01, or Model P9000-02 Differential Probe.

6 Tap the [Display] button to set it to [On] or [Off].

On	Displays the waveform on the waveform screen.
Off	Does not display any waveform on the waveform screen.

7 When the [Display] button has been set to [On], tap the box next to [On] on the right, and choose a display color from the color pallet.

You can also choose the same color as the lines acquired across other channels.

8 Switch the channels.

Tap the corresponding location to switch the channels, and then set the measurement conditions by following the procedure above.

3.4 Configuring the Level Trigger Settings

The trigger function allows you to start and stop measurement using specific signals. When recording is started or stopped by specific signals, it is called “The instrument is triggered.” The trigger function is useful to find trends in unexpected events. This section explains “level trigger,” which triggers the instrument at a specified value. For details about triggers other than the level trigger, refer to “5 Configuring the Trigger Settings” of Instruction Manual.

Cross-trigger settings

 > [Trigger] > [Common]

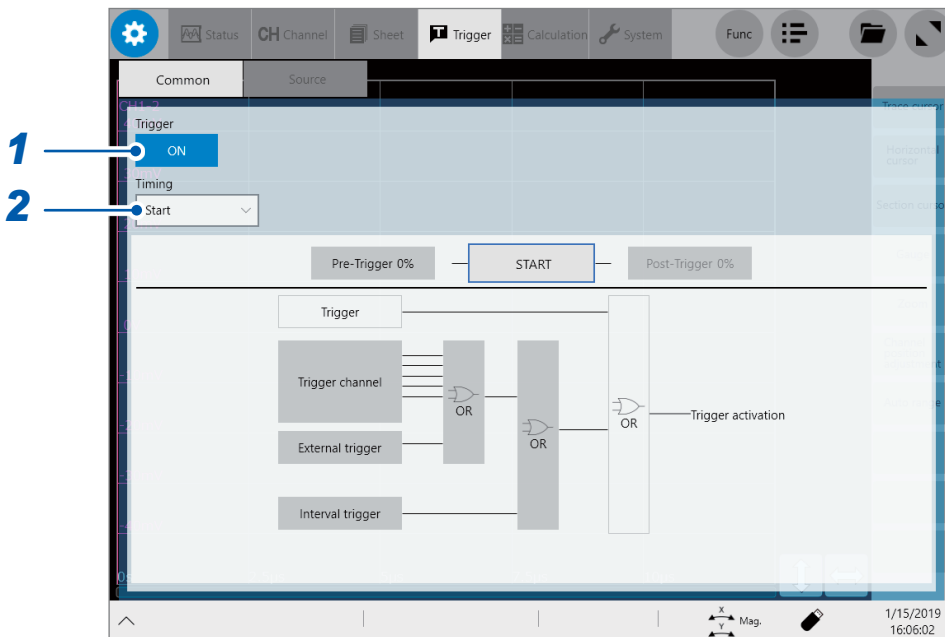

1 Tap the [Trigger] button to set it to [ON] or [OFF].

When the real-time save is set to [On], you cannot use the trigger function.

OFF <input checked="" type="checkbox"/>	Disables the trigger function.
ON <input type="checkbox"/>	Enables the trigger function.

2 Tap the [Timing] box, and then choose a trigger recording method from the list.

Start <input checked="" type="checkbox"/>	Starts recording when the instrument is triggered, and stops the recording after the instrument has acquired the recording length of waveforms.
Stop <input type="checkbox"/>	Starts recording when you press the START key, and stops the recording when the instrument is triggered.
Start/Stop <input type="checkbox"/>	Starts recording when a start trigger is activated and records data until a stop trigger is activated.

Configuring the trigger source settings

 > [Trigger] > [Source]

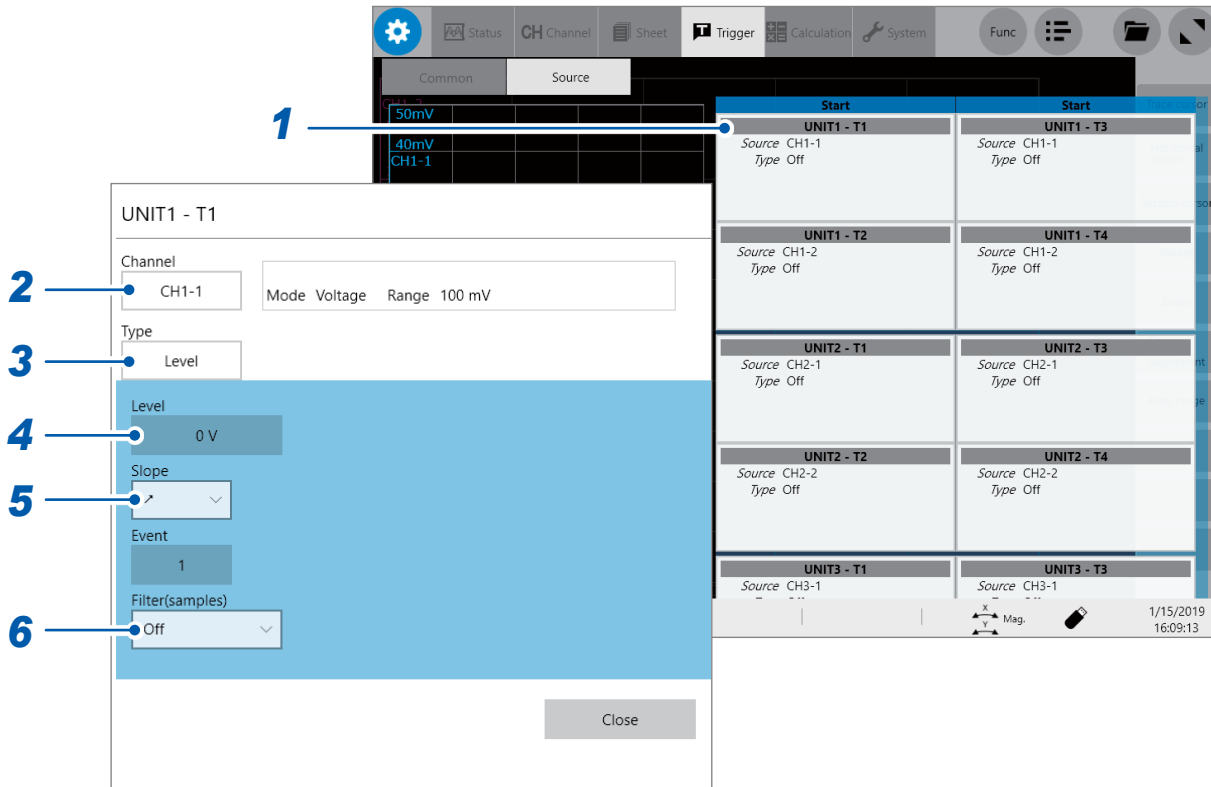

1 Tap a trigger source to be set.



The setting dialog box will appear.
You can set up to four triggers per module.

2 Tap the [Channel] box, and then choose a channel to be used for the level trigger from the list.

3 Tap the [Type] box, and then choose [Level] from the list.

4 Tap the [Level] box, and then enter a threshold value the level trigger condition is satisfied at.

5 Tap the [Slope] box, and then choose a signal direction that allows the level trigger condition to be satisfied from the list.

	The level-trigger condition is satisfied when a signal crosses the threshold value entered in the [Level] box in the positive direction.
	The level-trigger condition is satisfied when a signal crosses the threshold value entered in the [Level] box in the negative direction.

6 Tap the [Filter] box, and then choose a sampling count of the filter from the list.

Only after the level-trigger condition is continuously satisfied during the specified period, an analog trigger is generated. This is useful to prevent the instrument from triggering due to noise.

3.5 Starting/Stopping a Measurement

Starting a measurement



Pressing the **START** key starts a measurement. Waveforms shown on the screen are cleared once the measurement starts.

Stopping the measurement



Pressing the **STOP** key once stops the measurement after the instrument has acquired the specified recording length of the waveforms.



Pressing the **STOP** key twice stops the measurement immediately.

Initializing the instrument (Restoring the basic settings)

Select  > **[System]** > **[Initialize]** to restore the instrument settings to the factory default. The setting after the initialization is suitable for simple measurement. Initialize the instrument when you have found any unexpected or complicated operation. Refer to “6.2 Initializing the Instrument” (p. 139).

To configuring measurement settings automatically

Tapping **[Auto range]** on the waveform screen automatically configures the settings for the sampling rate, measurement range, and zero position of an input waveform, and then starts a measurement.

The instrument sets the zero position before starting the measurement. Refer to “3.7 Measuring Signals With the Auto-range Setting” (p. 81).

3.6 Saving Data Consisting of Items Selected

Save types and setting procedure

There are mainly three types of save operation.

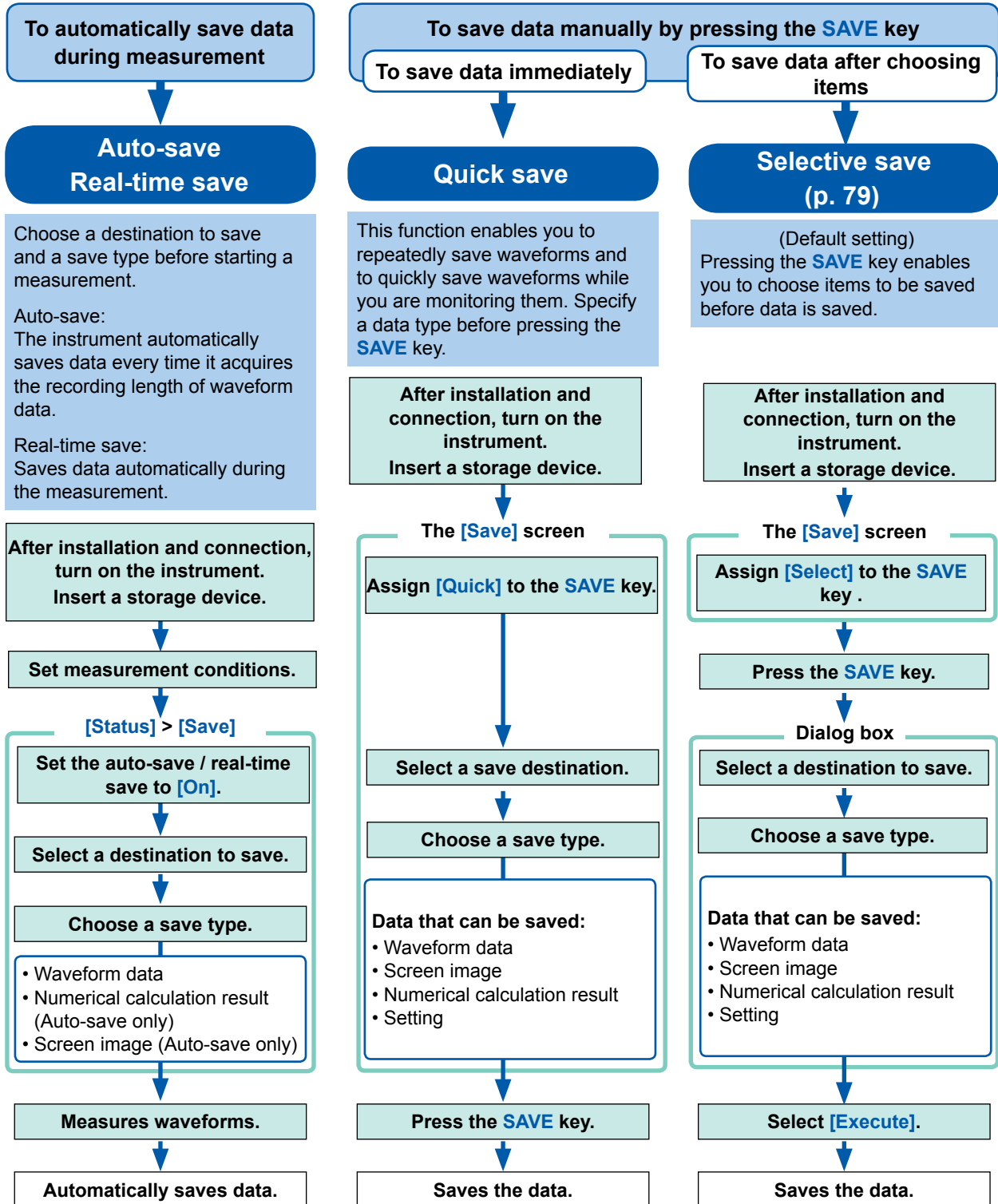

Check the following before saving data:

- Have you already inserted and initialized a storage device?
Refer to "Formatting storage devices" (p. 61).
- Is the destination to save specified correctly?
- When the auto-save is used, is [Auto save settings] set to [On]?

Selective save

Pressing the **SAVE** key allows you to choose any of the following items and save them:

- Waveform data
- Screenshot
- Numerical calculation result
- Setting

Refer to “4 Saving/Loading Data and Managing Files” of Instruction Manual.

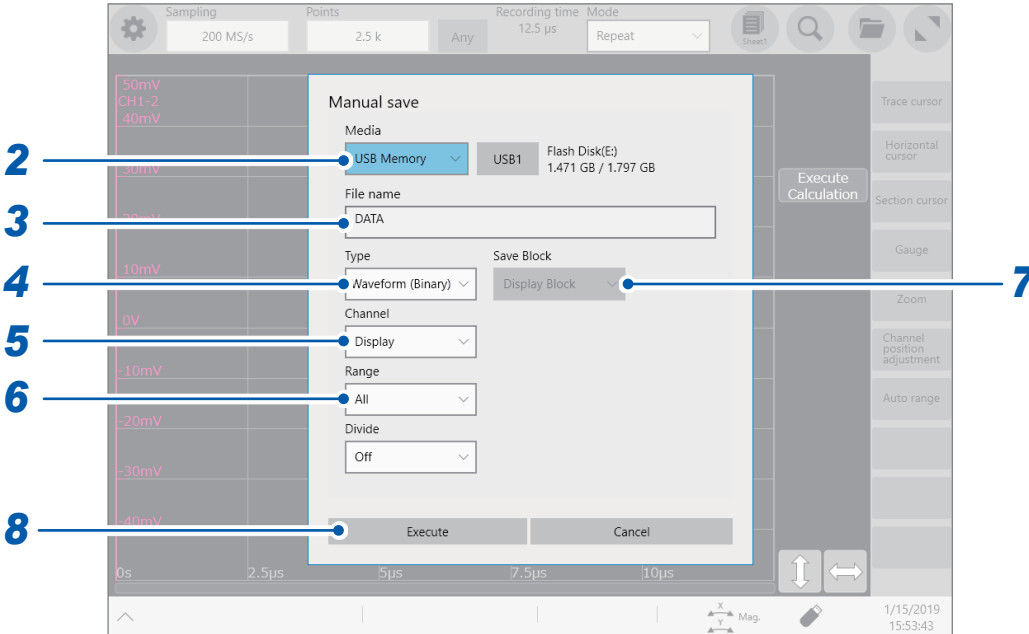

1 Press the **SAVE** key.

2 Tap the **[Mode]** box, and then choose a destination to save from the list.

SSD/HDD	Saves data on the built-in SSD/HDD.
SD Card	Saves data on the SD memory card.
USB flash drive	Saves data on the USB flash drive.
E-mail transmission	Sends email messages with waveform data attached to computers in the network or to a remote computer. Refer to “12.5 Sending Email Messages” of Instruction Manual.
FTP transfer	Sends waveform data to a computer connected to a network. Refer to “12.3 Sending Data to a computer With the FTP Client Function” of Instruction Manual.

3 Enter the file name in the **[File name]** box.

Number of characters for a file name: Up to 100 characters
 The maximum length of a file name that includes its path: Up to 255 characters
 Some characters or symbols are not accepted due to the file system restrictions.
 Refer to “Touch keyboard” (p. 34).

4 Tap the **[Type]** box, and then choose a save format of waveform data or save target from the list.

Waveform (Binary) [☐]	Saves waveform data in binary format. Choose this option to reload the waveforms into the instrument.
Waveform (Text)	Saves waveform data in text format. Choose this option to load the waveform data into a computer. The instrument cannot read this type of files.
Waveform (Float)	Saves waveform data in binary format (32-bit floating point). Choose this option to load the waveform data into MATLAB. The instrument cannot read this type of files.
Screen image	Saves image data on the screen in BMP, PNG or JPEG format. You can display the data saved on a computer with image viewing software.
Calc. Result	Saves numerical calculation results.
Setting	Saves the present measurement conditions.

When the save type is set to **[Waveform (Binary)]** or **[Waveform (Text)]**

5 Tap the **[Channel]** box, and then choose an option for channels to be saved.

All	Saves waveform data acquired across channels with the [Use] button set to [On] on the channel screen. The instrument saves waveform data acquired across channels with the [Use] button set to [On] even when the [Display] button of each channel is set to [Off] .
Display [☐]	Saves waveform data acquired across channels with the [Display] button set to [On] on the channel screen.

6 Tap the **[Range]** box, and then choose an option for save range from the list.

All [☐]	Saves the whole recorded waveform data.
Segment 1	Saves the waveform data in the section between section cursors [1A] and [1B] .
Segment 2	Saves the waveform data in the section between section cursors [2A] and [2B] .

When using the memory division function

7 Tap the **[Save Block]** box, and then choose an option for blocks to be saved.

Display block [☐]	Saves waveforms included in displayed blocks.
ALL blocks	Saves waveforms included in blocks being used beginning from the start block.

8 Tap **[Execute]**.

3.7 Measuring Signals With the Auto-range Setting

The auto-range function is available only for signals inputted to analog measuring modules. You cannot use the auto-range function concurrently with the envelope function.

- 1 Input signals to an analog measuring module.
- 2 Tap **[Auto range]** on the waveform screen.
- 3 Tap **[Execute]**.

The instrument specifies the sampling rate, measurement range, and zero position for each input waveform automatically, and starts a measurement.

The sampling rate is appropriately specified according to the lowest numbered channel among the channels with the **[Display]** button set to **[On]**. In addition, it is automatically specified so that waveforms have a length of one cycle to 2.5 cycles while 2500 points are recorded.

The auto-range function changes the following items:

Module conditions (for all channels)	
Range (f.s.)	Automatically specified value
Zero position	
L.P.F	Off
Input coupling	DC

Triggering condition (for one channel only)	
Selecting the trigger logical operation (AND or OR) among trigger sources	OR
Pre-trigger	20%
Internal trigger	Detects trigger levels beginning from the channel lowest-numbered among the channels with the [Display] button set to [On] .
Trigger type	Level trigger (Slope: ↗, Level: Automatically specified value, Filter: 10 samples)

Measurement conditions	
Sampling rate	Automatically specified value
Points	2.5 k
Mode	Repeat

- Be careful when performing auto-range measurement while using the TRIG OUT signals. Starting a measurement with the auto-range setting outputs a trigger signal from the TRIG.OUT terminal.
- Input signals (waveforms) before starting a measurement with the auto-range setting. The auto-range function changes the setting depending on a signal inputted on the start of execution.
- When an input signal acquired across the channel lowest-numbered among the channels with the **[Display]** button set to **[On]** has an extremely small level, the sampling rate is specified depending on the input signal of the next lowest-numbered channel.
- If the range setting fails for every channel with the **[Display]** button set to **[On]**, the instrument displays a warning message and cancels the measurement.
- When the auto-save is set to on, the instrument saves the data after specifying the setting value of the auto-range.
- The instrument cannot choose an adequate automatic range for a signal with a frequency of lower than 10 Hz. Manually choose a measurement range.
- The auto-range function is not available for the following modules:
 - Model 8967 Temp Unit
 - Model U8969 Strain Unit
 - Model 8970 Freq Unit
 - Model MR8990 Digital Voltmeter Unit
 - Model 8973 Logic Unit

4 Analysis Method

4.1 Reading Measured Values (Trace Cursors)

You can read measured values (scaled values when the scaling is used) using trace cursors on the waveform screen. The instrument can simultaneously display up to eight trace cursors. You can read differences in times and measured values at any two cursors you choose from among all cursors.

1 Tap [Trace cursor] on the wave screen.



2 Choose one or more cursors from [Trace cursor A] through [Trace cursor H] by tapping them.

The chosen trace cursors are displayed on the waveform screen. Drag the trace cursors on the waveform screen to move them.

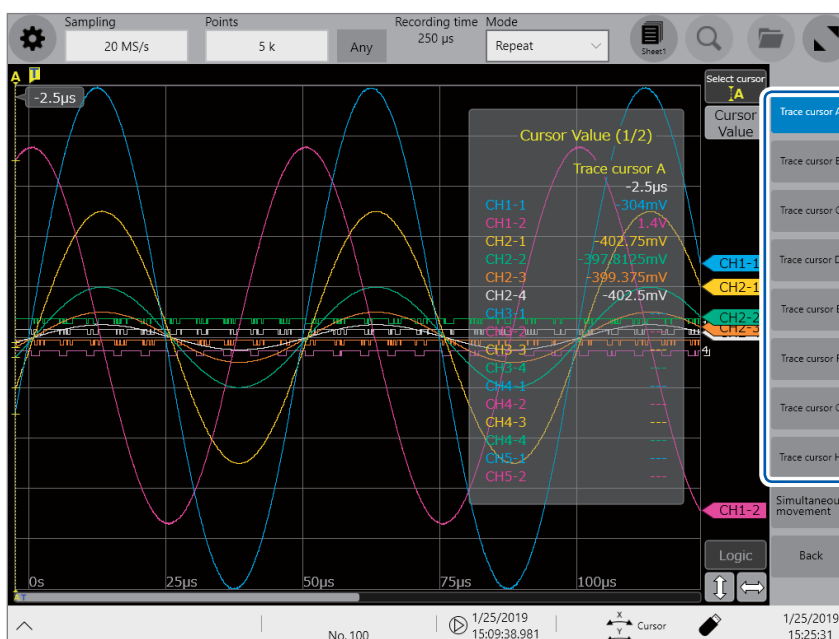

3 Tap [Back].

4 Tap [Cursor Value].

You can switch between on and off for the cursor value display every time you tap [Cursor Value].

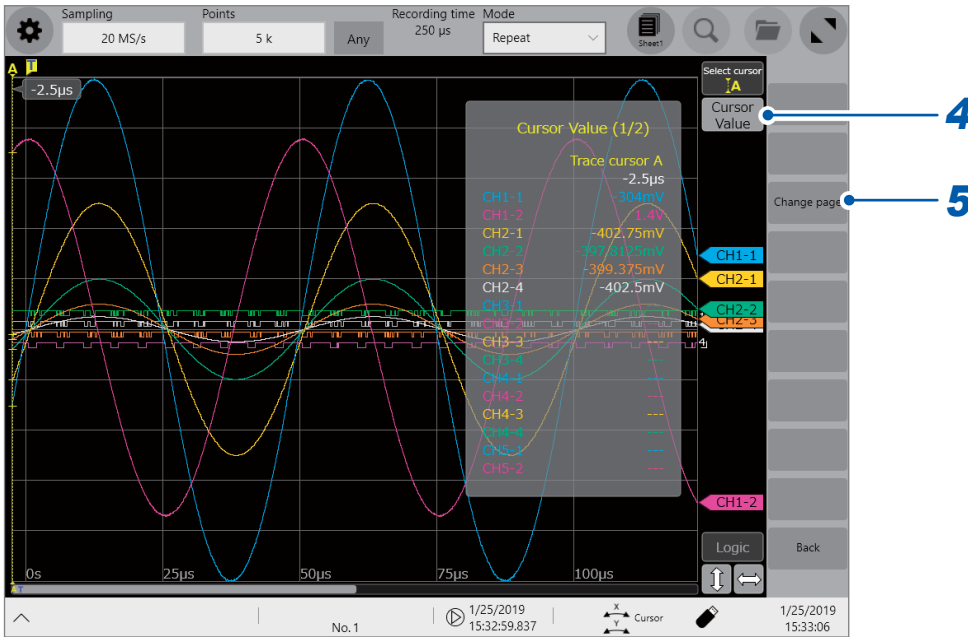

5 Tap [Change page].

When the instrument displays multiple channels, you can switch the pages to check cursor values of each channel.

Every time you tap it, the pages are switched.

6 Tap [1: Trace cursor] or [2: Trace cursor].

When the instrument displays multiple trace cursors, the cursor values acquired at the two trace cursors are displayed on the waveform screen (cursor values 1 and 2).

Every time you tap [1: Trace cursor] (or [2: Trace cursor]), you can switch the trace cursors displayed on the values of cursor values 1 (or cursor values 2).

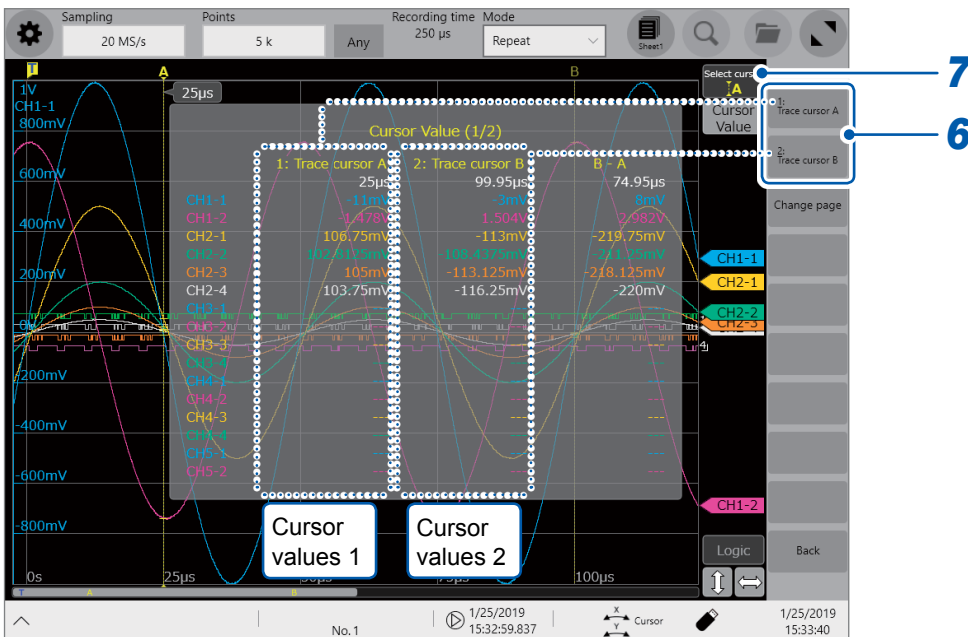

7 Tap [Select cursor].

Every time you tap it when the instrument displays multiple trace cursors, a cursor is activated one by one in sequence. In addition, you can activate any one of the cursors displayed on the screen by tapping it.

While you are operating the cursors on the waveform screen, the instrument may not display [Cursor] and [Select cursor] depending on the screen operation.

In this case, tap the waveform plotting field to redisplay [Cursor] and [Select cursor].

Changing the display magnification of waveforms while moving the trace cursor

Sliding your finger upward on the screen while dragging the trace cursor enlarges the waveform display centered around the trace cursor in proportion to the dragging distance. Sliding your finger downward compresses the waveform display.

Once you have adjusted the display to a suitable size, move the trace cursor along the horizontal axis to change the display position.

Releasing your finger from the screen reverts the display to the original magnification.

4.2 Handling Waveforms

Scrolling through waveforms

You can use the scroll bar to check the position of waveforms presently displayed on the waveform screen.

Drag the scroll bar to scroll through the waveforms.

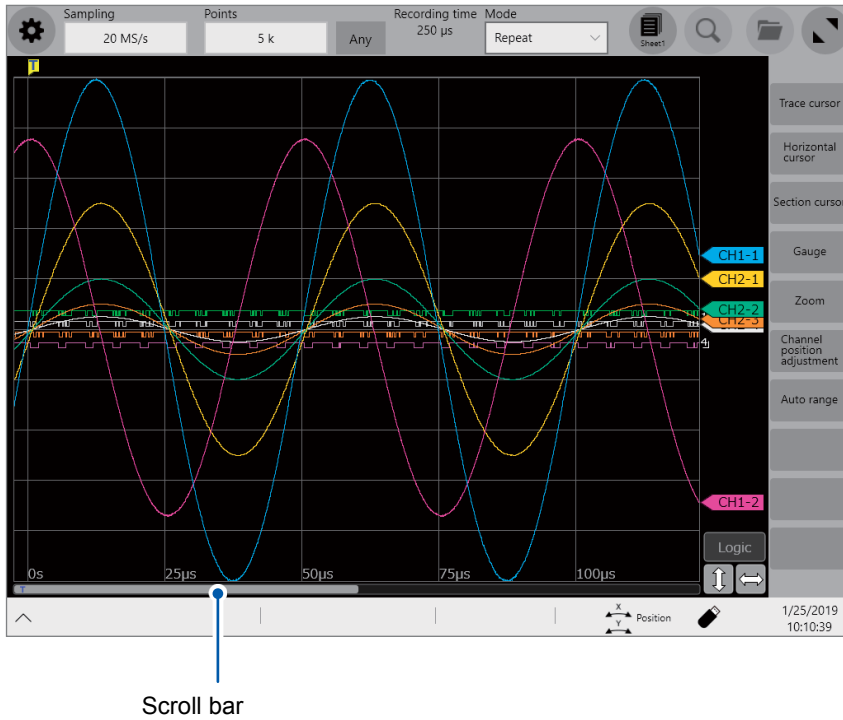

Zooming in and out waveforms

Horizontally pinching in or pin out the waveform screen enlarges or compresses waveforms horizontally.

Vertically pinching in or pin out the waveform screen enlarges or compresses waveforms vertically

	Pinch out		Zooms in waveforms.
	Pinch in		Zooms out waveforms.

4.3 Loading Data on Your Computer (Wave Viewer)

You can load waveform data saved in CSV format into spreadsheets. This section explains how to install, uninstall, start, and exit the Wave Viewer.

Supported computer: Computers running on Windows 7, or Windows 8, or Windows 10

Installing Wave viewer (for computers running on Windows 7)

- 1 Insert the accompanying application disc into the CD-ROM drive.**
The top page appears automatically.
If the page does not appear, open the "index.htm" file with your web browser.
- 2 Choose a display language (Click the [English] icon to display the installation program in English).**
- 3 Click the [Wave viewer (Wv)] icon.**
The specifications and revision history of Waveform viewer (Wv) appear.
- 4 Click the [Install] icon at the top right of the page.**
The [File Download] dialog box appears.
- 5 Click [Open].**
The confirmation dialog box appears to check whether to continue the installation.
- 6 Click [Next].**
The window for selecting the installation folder opens.
Click [Browse] to change the installation folder.
- 7 Click [Next].**
The installation starts.

Starting Wave viewer

Before using Wave viewer, read the “READ ME.txt.”

Click the Start button of Windows®, select [Program] > [HIOKI] > [Wv].

Waveform Viewer starts.

Exiting Wave viewer

On the [File] menu of Wave viewer, click [Exit].

Alternatively, you can click the [Close] button at the top right of the screen.

Uninstalling Wave viewer

- 1** Click the Start button to display the Windows® start menu, and then select [Control Panel] > [Add or Remove Programs].

When you use Windows 10, click the Start button and select [Setting] > [System] > [Apps and Features].

- 2** Right-click [HIOKI Wave Viewer (Wv)] to display the shortcut menu, and then click [Uninstall].

Wave viewer is uninstalled.

When updating Wave viewer to the latest version, uninstall the earlier version before installing the latest version.

5.1 Specifications of Model MR6000

General specifications

1. Basic specifications

Measurement method	Normal: Records waveforms normally. Envelope: Records the maximum and minimum values during each specified period. (Not available when the external sampling is used.)
Number of channels	Analog: Up to 32 channels (when Model U8975 4ch Analog Unit or Model U8978 4CH Analog Unit is installed in every slot) Logic: Up to 128 channels (when Model 8973 Logic Unit* is installed in every slot*) *: The logic probe input connectors have the same-potential ground as Model MR6000.
Maximum sampling rate	200 MS/s (when Model U8976 High Speed Analog Unit is used), Samples values acquired across all channels simultaneously. 10 MS/s for external sampling
Memory capacity	1 gigaword
Operating environment	Indoors, Pollution Degree 2, Operating altitude: up to 2000 m (6562 ft.)
Operating temperature and humidity	0°C to 40°C (32°F to 104°F), 80% RH or less (no condensation)
Storage temperature and humidity	-10°C to 50°C (14°F to 122°F), 80% RH or less (no condensation)
Standards	Safety: EN61010 EMC: EN61326 Class A
Power supply	Rated supply voltage: 100 V to 240 V AC (Voltage fluctuations of up to ±10% centered on the rated supply voltage are allowed.) Rated supply frequency: 50 Hz / 60 Hz Anticipated transient overvoltage: 2500 V
Maximum rated power	300 VA
Clock	Automatic calendar, automatic leap year adjustment, 24-hour clock
Backup battery life	About 10 years (at 23°C, for reference) Backup for the clock and setting conditions
Interfaces (outline)	LAN, USB, SD, SATA, monitor
Dimensions	Approx. 353W × 235H × 154.8D mm (13.90"W × 9.25"H × 6.09"D) (excluding protrusions)
Mass	Approx. 6.5 kg (229.3 oz.) (instrument only) Approx. 6.7 kg (236.3 oz.) (When Model Z5021 Probe Power Unit, and either Model U8332 SSD Unit or Model U8333 HD Unit are installed) Approx. 8.9 kg (313.9 oz.) (When Model U8976 High Speed Analog Unit is installed)
Product warranty period	3 years
Accessories	p. 4
Options	p. 5

2. Specifications for accuracy

Conditions of guaranteed accuracy	Guaranteed accuracy period: 1 year Temperature and humidity for guaranteed accuracy: 23°C ±5°C (73°F ±9°F), 80% RH or less
Time axis accuracy	±0.0005%
Clock accuracy	±8 ppm

3. Display

Display type	12.1-inch XGA TFT color LCD (1024 × 768 dots) With capacitive touch panel
---------------------	--

4. Specifications of the interfaces

(1) LAN interface

Standards	IEEE802.3 Ethernet 1000BASE-T, 100BASE-TX, 10BASE-T
Functions	DHCP, DNS, FTP, HTTP, email transmission
Connector	RJ-45
Maximum cable length	100 m

(2) USB interface

Standards	USB 3.0 compliant ×3, USB 2.0 compliant ×4
Host	Connector: Series-A receptacle Peripheral devices: keyboard, mouse, USB flash drive
Available option	Model Z4006 USB Drive (16 GB)

(3) SD card slot

Standards	SD standard compatible ×1 (with support for SD, SDHC, SDXC memory card)
Available option	Model Z4001 SD Memory Card (2 GB), Model Z4003 SD Memory Card (8 GB)

(4) SATA interface

Standards	Serial ATA Revision 3.0 compatible × 1
Available option	Model U8332 SSD Unit (256 GB), Model U8333 HD Unit (320 GB)

(5) Output for monitor

Connector	DVI-I
Output format	Digital output for external display 1024 × 768 (XGA) Dual-link not supported

5. Auxiliary I/O

(1) External sampling terminals

Connector	SMB
Maximum input voltage	10 V DC
Input voltage	High level: 2.5 V to 10 V, low level: 0 V to 0.8 V
Acceptable pulse width	High-level period: 50 ms or more; Low-level period: 50 ms or more
Maximum input frequency	10 MHz
Functions	External sampling clock input The edge to be used can be chosen between rising and falling.

(2) External control terminals

Terminal block	Push-button type		
External input	Maximum input voltage	10 V DC	
	Input voltage	High level: 2.5 V to 10 V, low level: 0 V to 0.8 V	
	Acceptable pulse width	High-level period: 50 ms or more; low-level period: 50 ms or more	
	Pulse interval	200 ms or more	
	Number of terminals	2	
	Functions	START, STOP, START/STOP, SAVE, ABORT, EVENT	
External output	Output format	Open-drain output (equipped with a 5-volt voltage output, active-low)	
	Output voltage	High level: 4.0 V to 5.0 V, low level: 0 V to 0.5 V	
	Maximum input voltage	50 V DC, 50 mA, 200 mW	
	Number of terminals	2	
	Functions	Judgment (pass), judgment (fail), occurrence of an error, busy, waiting for a trigger	
External trigger	Maximum input voltage	10 V DC	
	External trigger filter	On/Off	
	Acceptable pulse width	When the external trigger filter is off High-level period: 1 ms or more, low-level period: 2 μs or more	
		When the external trigger filter is on High-level period: 2.5 ms or more; low-level period: 2.5 ms or more	
	Functions	The edge to be used can be chosen between rising and falling. Rising: Triggered when a pulse rises from the low level (between 0 V and 0.8 V) to the high level (between 2.5 V and 10 V). Falling: Triggered when a pulse falls from the high level (between 2.5 V and 10 V) to the low level (between 0 V and 0.8 V), or when the terminal is connected with the GND terminal. (When the trigger timing is set to [START&STOP] , the edge to be used can be chosen between rising or falling for each of [START] and [STOP] .)	

Trigger output	Output format	Open-drain output (equipped with a 5-volt voltage output, active-low)
	Output voltage	High level: 4.0 V to 5.0 V, low level: 0 V to 0.5 V
	Maximum input voltage	50 V DC, 50 mA, 200 mW
	Output pulse width	The pulse width to be used can be chosen between level and pulse. Level: [(sampling interval) × (number of data points after trigger)] or more Pulse: 2 ms ±1 ms

(3) Probe compensation signal output terminal

Output signal	0 V to 5 V ±10%, 1 kHz ±1%, square wave
Functions	Compensation of Model 9665 10:1 Probe and Model 9666 100:1 Probe

(4) Dedicated power terminals for current sensors

Applicable to the instrument with Model Z5021 Probe Power Unit (the option available only when ordered with the instrument) installed.

Number of terminals	Consistent with the specifications of Model Z5021 Probe Power Unit
Output voltage	Consistent with the specifications of Model Z5021 Probe Power Unit

Trigger

When the real-time save is set to **[On]**, the trigger function is not available.

Trigger method	Digital comparison method
Trigger conditions	Logical AND or OR operation among each trigger source and the interval trigger
Trigger source	<p>Analog, logic, real-time waveform calculation</p> <ul style="list-style-type: none"> • When [START] or [STOP] is chosen: Up to 32 channels (Up to four analog triggers are available for one analog channel.) (Up to four logic triggers are available for one logic probe.) (Up to two analog triggers are available for one real-time waveform calculation channel.) • When [START&STOP] is selected: Up to 16 channels per group Analog: Up to 16 channels per group (Two channels can be selected per module.) Logic: Up to 16 probes per group (Two probes can be selected per module.) Real-time waveform calculation: Up to 16 calculations per group (Up to two trigger types per group are available for each analog channel.) (Up to two logic triggers per group are available for each logic probe.) <p>External trigger The instrument immediately starts a measurement (freely running) when all trigger sources are set to off.</p>
Analog trigger	<p>Level trigger: The instrument is triggered when an input signal voltage exceeds (or falls below) a user-defined voltage level.</p> <p>Voltage sag trigger*: The instrument is triggered when the peak voltage of an input signal falls below a user-defined voltage. (Dedicated to 50 Hz / 60 Hz commercial power) (Not available when Model MR8990 Digital Voltmeter Unit or Model 8970 Freq Unit is used.) (Not available when the envelope is used.)</p> <p>Window trigger*: A range, which is defined by an upper level and lower level, shall previously be specified. The instrument is triggered when an input signal voltage falls within (IN) or outside (OUT) the user-defined range.</p> <p>Period trigger*: A period-measuring level and a period range shall previously be specified. The instrument measures periods by acquiring moments when a voltage exceeds (or falls below) a user-defined level, and is triggered when a period falls outside or within the user-defined range. (Not available when Model MR8990 Digital Voltmeter Unit or Model 8970 Freq Unit is used.) (Not available when the envelope is used.)</p> <p>Glitch trigger*: A voltage level and a pulse width (glitch width) shall be previously specified. The instrument measures pulse widths by acquiring moments when rising edges (or falling edges) cross the user-defined level and is triggered when a signal pulse width becomes narrower than the user-defined pulse width. (Not available when Model MR8990 Digital Voltmeter Unit is used.) (Not available when the envelope is used.)</p> <p>Event designation: The number of events shall previously be specified (1 to 4000). The instrument counts the number of times the trigger condition of each trigger source is satisfied and is triggered when the event counts exceeds the user-defined number. (Not available when the trigger condition is set to AND.)</p> <p>*: Setting invalid with the sampling rate set at 200 MS/s</p>

Logic trigger	Pattern trigger defined by 1, 0, or disregard (×)
Forcible trigger	Available (A forcible trigger can trigger the instrument in priority to any trigger sources.)
Interval trigger	Data can be recorded at a user-defined measuring interval (in hours, minutes, and seconds). The instrument is triggered at the start of a measurement and then repeatedly triggered at a user-defined measurement interval.
Trigger filter	Normal: Off, 10, 20, 50, 100, 150, 200, 250, 500, 1000, 2000, 5000, 10000 (samples) Envelope: Off, 1 ms, 10 ms
Trigger level resolution	1 LSB 256 LSB for Model MR8990 Digital Voltmeter Unit (uses only high 16 bits of the 24-bit A/D resolution)
Pre-trigger	0% to 100% (freely settable in one percentage point increments) The instrument displays waveforms acquired during the pre-trigger period.
Post-trigger	0% to 40% The instrument displays waveforms acquired during the post-trigger period.
Trigger priority	On/Off
Trigger mark	The instrument displays trigger marks, which indicate the positions of trigger events.
Trigger timing	[START], [STOP], [START&STOP]
Waveform monitor display	While waiting for a trigger, the instrument displays the waveform monitor (Hiding the monitor is available).

Waveform screen

Display format	Time-domain waveform representation: FFT representation:	1, 2, 4, 8, 16 screens (Up to 64 channels can be displayed on each sheet.) (Every channel can be set to be displayed on multiple sheets.) 1, 2, 4 screens, combination of time-domain waveform and FFT representation (1, 2, 4 screens)
Sheet function	Up to 16 sheets A display format can be chosen for each sheet.	
Zoomed display	On/Off The instrument displays time-domain waveforms on the upper waveform screen and zoomed waveforms on the lower screen.	
Full-screen display	The instrument zooms the waveform screen to full screen.	
Waveform display	Waveform color: Interpolation: Variable display: Vernier: Grid: Logic width: Inverted waveform:	Fixed colors (32 colors) Line Always on Amplitudes of inputted waveforms can be adjusted. (Adjustable range: 50% to 250% of input) Off/On Wide, standard, narrow The instrument displays polarity-reversed waveforms. (Not available for Model 8967 Temp Unit, Model 8970 Freq Unit, or Model 8973 Logic Unit)
Zoom in/out	The instrument displays waveforms at a user-preferred magnification by pinching in or out the display.	
Waveform scrolling	Waveforms can be scrolled through horizontally by flicking the display. Scrolling through waveforms backward is available during a measurement.	
Rolling display	The instrument always displays latest data while following measurement. The drawing starting position can be chosen between the left edge and right edge. (The rolling display is not available when the overlay setting is used.)	
Waveform monitor function	On/Off (The instrument can display the waveform monitor while waiting for a trigger.)	
Overlaying waveforms	Overlaying setting can be chosen from among off, automatic, and manual. (The rolling display is not available when the overlay setting is used.)	
Cursor	Trace cursor: Horizontal cursor: Gauge: Section designation: Jump:	Up to eight cursors can be displayed. (The instrument displays potential, time from trigger, time lag between cursors, and potential difference between cursors.) Up to eight cursors can be displayed. (The instrument displays potential and potential difference between cursors.) Up to eight cursors can be displayed. Section cursor 1 or section cursor 2 (Specifies calculation range, save range, and search area.) Jumps to the position specified by touch operation.
Event mark	Can be placed during measurement (up to 1000 markings). Event marks can be placed by pressing the START key or inputting an external signal.	

Setting screen

Sampling rate	Normal	<p>200 M, 100 M, 50 M, 20 M, 10 M, 5 M, 2 M, 1 M 500 k, 200 k, 100 k, 50 k, 20 k, 10 k, 5 k, 2 k, 1 k 500, 200, 100, 50, 20, 10, 5, 2, 1 (unit: S/s)</p> <p>The sampling rate can be set at 100 MS/s or slower when the real-time waveform calculation is used.</p> <p>When the external sampling is used: Depends on a signal input to the external sampling terminal. Up to 10 MHz</p>
	Envelope	<p>10 M, 5 M, 2 M, 1 M 500 k, 200 k, 100 k, 50 k, 20 k, 10 k, 5 k, 2 k, 1 k 500, 200, 100, 50, 20, 10, 5, 2, 1 (unit: S/s) 30, 12, 6, 2, 1 (unit: S/min)</p> <p>The sampling rate for the envelope setting means the speed of calculating the maximum and the minimum values. Oversampling rate: 100 MS/s</p>
	For the real-time save setting	<p>Available maximum sampling rate</p> <p>When the destination to save data is set to SSD: 20 MS/s (2 ch.), 10 MS/s (4 ch.), 5 MS/s (8 ch.), 2 MS/s (16 ch.), 1 MS/s (32 ch.), 500 kS/s (64 ch.)</p> <p>When the destination to save data is set to HDD: 10 MS/s (2 ch.), 5 MS/s (4 ch.), 2 MS/s (8 ch.), 1 MS/s (16 ch.), 500 kS/s (32 ch.), 200 kS/s (64 ch.)</p> <p>When the destination to save data is set to SD memory card, USB flash drive, or FTP transmission: 5 MS/s (1 ch.), 2 MS/s (4 ch.), 2 MS/s (8 ch.), 500 MS/s (16 ch.), 200 kS/s (32 ch.), 100 kS/s (64 ch.)</p> <ul style="list-style-type: none"> • The figures in above parentheses means the number of channels to be used. • Only when the available optional devices are specified as the destination to save data, the sampling rates are guaranteed. • The operation of the USB flash drive is guaranteed only when the drive connects to the USB 3.0 connector.

Maximum recording length	Normal	<p>For the fixed recording length setting: 20 M (32 ch.), 50 M (16 ch.), 100 M (8 ch.), 200 M (4 ch.), 500 M (2 ch.), 1 G (1 ch.) (unit: points)</p> <p>For freely-specified recording length: 33554400 (32 ch.), 67108800 (16 ch.), 134217700 (8 ch.), 268435400 (4 ch.), 536870900 (2 ch.), 1073741800 (1 ch.) (unit: points) Can be set in 100 points increments</p>
	Envelope	<p>For the fixed recording length setting: 10 M (32 ch.), 20 M (16 ch.), 50 M (8 ch.), 100 M (4 ch.), 200 M (2 ch.), 500 M (1 ch.) (unit: points)</p> <p>For freely-specified recording length: 16777200 (32 ch.), 33554400 (16 ch.), 67108800 (8 ch.), 134217700 (4 ch.), 268435400 (2 ch.), 536870900 (1 ch.) (unit: points) Can be set in 100 points increments</p>
	For the real-time save setting	The maximum recording length is defined depending on a free space of a destination, file systems, and the number of measuring channels.
<ul style="list-style-type: none"> • The numbers in parentheses above show the number of channels to be used. • For Model U8975 4ch Analog Unit and Model U8978 4CH Analog Unit, consider that use of a combination of CH1 and CH2 or that of CH3 and CH4 occupies one channel. For Model U8977 3CH Current Unit, consider use of a combination of CH1 and CH2 occupies one channel. For the real-time waveform calculation, consider an expression occupies one channel. • When either any one of Model U8975, U8977, U8978, and MR8990 or the real-time waveform calculation is used, each maximum recording length reduces to half or less for a sampling rate of 10 MS/s or slower. 		
Repeat measurements	Single, repeat, count (Repeat and count are not available for the real-time save.)	
Waveform monitor function	The instrument displays waveforms on the channel setting screen	
Scaling	Ratio and offset, 2-point, model name, output rate, decibel, rating Model name: The scaling is automatically specified by choosing a connected model. The combination use of auto-recognition and auto-scaling is supported when a current measuring module is used.	
Comment	Title comment, channel comment The instrument displays both of channel numbers and channel comments on the setting and waveform screens.	
Help	The instrument displays the instruction manuals.	

**Digital filter
(Model MR6000-01
only)**

Maximum number of 32 expressions
expressions:

Calculation target: Measurement channel of the following modules:
Models 8966, 8967, 8968, U8969, 8970, 8971, 8972, U8974, U8975,
U8976, U8977, U8978, and U8979
(Measurement channels of Model 8973 Logic Unit and Model
MR8990 Digital Voltmeter Unit are not supported.)

Calculation refresh rate: 10 M, 1 M, 100 k, 10 k, 1 k, 100, 10, 1 (unit: S/s)
Up to eight calculations are available for the 10 MS/s setting.
Up to 16 calculations are available for the 1 MS/s setting.

Calculation delay:

Calculation refresh rate	10 MS/s	1 MS/s	100 kS/s	10 kS/s or lower
Calculation delay	6.2 μ s or 6.3 μ s	5 μ s	20 μ s	Calculation refresh interval

Filter type: FIR (LPF, HPF, BPF, BSF), IIR (LPF, HPF, BPF, BSF), moving average, delayer

File

1. Data saving

Destination to save	<p>SD memory card: Model Z4001 SD Memory Card (2 GB), Model Z4003 SD Memory Card (8 GB)</p> <p>USB flash drive: Model Z4006 USB Drive (16 GB)</p> <p>SSD: Model U8332 SSD Unit (256 GB)</p> <p>HDD: Model U8333 HD Unit (320 GB)</p> <p>FTP transfer: Computer connected via LAN</p> <p>Email transmission: The instrument sends email messages with a file attached to user-defined destination.</p>								
File format	FAT, FAT32, NTFS, exFAT								
File name	Alphanumeric file names can be entered.								
Handling of same-name files	A sequence number is added to the beginning of the file to be saved.								
Auto-save	<p>On/Off</p> <p>The instrument automatically saves the recording length of acquired data after each measurement.</p> <p>No setting files are supported.</p> <p>Not available when the real-time save is selected.</p> <p>With the memory division setting enabled, the instrument can start to measure the next block while saving data.</p>								
Real-time save	<p>On/Off</p> <p>The instrument directly saves waveform data (in binary) acquired to the destination during measurement.</p> <p>The auto-save cannot be set.</p> <p>File division: The instrument automatically divides a file for every additional size of about 512 MB.</p>								
Older-file overwriting	<p>If a free space of a destination is insufficient, the existing files are overwritten beginning with the oldest.</p> <p>(Enabled for the auto-save and the real-time save)</p>								
Saving format	<p>Setting data: .SET</p> <p>Waveform data: Binary (.MEM, .REC, .FLT), text (.CSV, .TXT)</p> <p>Index: Division save (.IDX) Memory division (.SEQ)</p> <p>Screen image: .BMP, .PNG, .JPG</p> <p>Numerical calculation result: .CSV, .TXT</p> <p>Start-up: STARTUP.SET</p>								
Channels to be saved	With the saving format set to waveform data, the channels to be saved can be chosen between all channels and displayed channels.								
Data decimation save	With the saving format set to waveform data (in text format), the instrument decimates data points by retaining one out of the specified decimation number (2 to 1000) and saves the remaining data points.								
File division (Not available for real-time save)	<table border="1"> <thead> <tr> <th>Saving format</th> <th>Division content</th> </tr> </thead> <tbody> <tr> <td>Binary format</td> <td>Off, every 16 MB, every 32 MB, every 64 MB</td> </tr> <tr> <td>Text format</td> <td>Off, every 60,000 pieces of data, every 1,000,000 pieces of data</td> </tr> <tr> <td>Numerical calculation result</td> <td>Off, by calculation number</td> </tr> </tbody> </table>	Saving format	Division content	Binary format	Off, every 16 MB, every 32 MB, every 64 MB	Text format	Off, every 60,000 pieces of data, every 1,000,000 pieces of data	Numerical calculation result	Off, by calculation number
Saving format	Division content								
Binary format	Off, every 16 MB, every 32 MB, every 64 MB								
Text format	Off, every 60,000 pieces of data, every 1,000,000 pieces of data								
Numerical calculation result	Off, by calculation number								

File designation	New file or existing file (Enabled when the saving format is set to the numerical calculation result) (Before starting a measurement, choose whether a new file is created or data is appended to the existing file)
SAVE key operation	Quick save: The SAVE key is used to save data based on a pre-defined destination, file name, and saving setting. Saving range: Selectable between whole range or a specified segment range (Available only for saving data started by pressing the SAVE key)

2. Data loading

Drive data is loaded from	SD memory card: Model Z4001 SD Memory Card (2 GB), Model Z4003 SD Memory Card (8 GB) USB flash drive: Model Z4006 USB Drive (16 GB) SSD: Model U8332 SSD Unit (256 GB) HDD: Model U8333 HD Unit (320 GB)
Loadable data formats	Setting data (.SET) Waveform data: Binary format (.MEM, .REC) Index: Division save (.IDX), memory division (.SEQ) Start-up: STARTUP.SET

Calculation

1. Numerical calculation

Numerical calculation is disabled when the envelope is used.

Maximum number of calculations	(16 items) × (the number of measuring channels)
Calculation range	Whole range or a specified segment range
Calculation items	P-P, maximum, minimum, high level, low level, average, RMS, standard deviation, rise time*, fall time*, frequency*, period*, duty ratio*, pulse count, area, X-Y area, time lag*, phase contrast*, time to maximum, time to minimum, time to level, level at time, pulse width*, arithmetic operation, intermediate, amplitude, accumulation, burst width*, angle of XY waveform, overshoot, undershoot, +Width*, -Width* *: Statistical functions (start, average, maximum, minimum) available
Numerical judgment	Target waveform: Analog channels, logic channels, real-time waveform calculation channels, waveform calculation results Judge setting: On/Off Stopping condition: PASS, FAIL, PASS&FAIL

2. Waveform calculation

The waveform calculation is disabled when the envelope is used. The waveform calculation cannot be used in combination with the real-time save.

Maximum number of calculations	16 expressions
Calculation range	Whole range or a specified segment range
Maximum recording length	2,000,000 points
Standard operators	+, -, ×, ÷
Calculation items	Absolute value, exponent, common logarithm, moving average, derivative, second derivative, integral, second integral, square root, cubic root, parallel move (translation), PLC shift, sine, cosine, tangent, arc sine, arc cosine, arc tangent, 2-argument arc tangent FIR (LPF, HPF, BPF, BSF), IIR (LPF, HPF, BPF, BSF), Average* ¹ , maximum value* ¹ , minimum value* ¹ , level at specified time* ¹ *1: Calculation results can be specified as constants in expressions.
Averaging	Simple average, exponential average (the number of averaging can be specified from 2 to 10,000) • With the averaging setting enabled, roll-mode display cannot be used. • Each simple average expression occupies three expressions (two expressions immediately following each of calculation numbers the simple average is specified to is not available).

3. Real-time waveform calculation (Model MR6000-01 only)

This function is optional function available only at the time of purchase order issuance for the instrument.

Maximum number of calculations	16 expressions																							
Calculation target	Measurement channels of the following modules: Models 8966, 8967, 8968, U8969, 8970, 8971, 8972, 8973, U8974, MR8990*, U8975, U8976, U8977, U8978, and U8979 *: Model MR8990 Digital Voltmeter Unit makes calculation using only the upper 16 bits of the 24-bit A/D resolution.																							
Calculation refresh rate	10 M, 1 M, 100 k, 10 k, 1 k, 100, 10, 1 (unit: S/s) • Up to eight calculations are available for the 10 MS/s setting. (Some of calculation types are not available depending on the refresh rate.)																							
Calculation delay	<table border="1"> <thead> <tr> <th>Calculation refresh rate</th> <th>10 MS/s</th> <th>1 MS/s</th> <th>100 kS/s</th> <th>10 kS/s or lower</th> </tr> </thead> <tbody> <tr> <td>Calculation delay</td> <td>6.2 μs or 6.3 μs</td> <td>5 μs</td> <td>20 μs</td> <td>Calculation refresh interval</td> </tr> </tbody> </table> <p>The following delays have to be added when a real-time waveform calculation channel is chosen for a calculation target.</p> <table border="1"> <thead> <tr> <th>Calculation refresh rate</th> <th>10 MS/s</th> <th>1 MS/s</th> <th>100 kS/s</th> <th>10 kS/s or lower</th> </tr> </thead> <tbody> <tr> <td>Calculation delay</td> <td>1.6 μs</td> <td>2 μs</td> <td>10 μs</td> <td>Calculation refresh interval</td> </tr> </tbody> </table>				Calculation refresh rate	10 MS/s	1 MS/s	100 kS/s	10 kS/s or lower	Calculation delay	6.2 μs or 6.3 μs	5 μs	20 μs	Calculation refresh interval	Calculation refresh rate	10 MS/s	1 MS/s	100 kS/s	10 kS/s or lower	Calculation delay	1.6 μs	2 μs	10 μs	Calculation refresh interval
Calculation refresh rate	10 MS/s	1 MS/s	100 kS/s	10 kS/s or lower																				
Calculation delay	6.2 μs or 6.3 μs	5 μs	20 μs	Calculation refresh interval																				
Calculation refresh rate	10 MS/s	1 MS/s	100 kS/s	10 kS/s or lower																				
Calculation delay	1.6 μs	2 μs	10 μs	Calculation refresh interval																				
Calculation type	Addition, subtraction, multiplication, division, arithmetic operation with coefficient, quadratic polynomial, monomial, polynomial add/subtract, derivation, integration, count, FIR (LPF, HPF, BPF, BSF), IIR (LPF, HPF, BPF, BSF), moving average, delayer																							

4. FFT calculation

The FFT calculation is disabled when the envelope is used. The FFT calculation cannot be used in combination with the real-time save.

Maximum number of calculations	8 expressions
Frequency range	500 mHz to 100 MHz ([sampling rate] × 0.5), external sampling
Number of sampling points	1 k, 2 k, 5 k, 10 k, 20 k, 50 k, 100 k
Frequency resolution	1/500, 1/1000, 1/2500, 1/5000, 1/10000, 1/25000, 1/50000
Anti-aliasing filter	AAF (Model 8968, Model U8979), LPF filter for waveform calculation (FIR, IIR), LPF filter for real-time waveform calculation (FIR, IIR)
Calculation target	Analog waveform, waveform calculation, real-time waveform calculation
Data to be analyzed	Newly acquired: Data newly acquired by pressing the START key Memory: Data previously measured or loaded from a storage device
Calculation type	Linear spectrum, RMS spectrum, power spectrum, 1-channel phase spectrum, cross power spectrum, transfer function, coherence function, 2-channel phase spectrum.
Window function	Rectangular, Hann (also referred to as <i>Hanning</i>), Hamming, Blackman, Blackman-Harris, flat top, exponential
Display scale	Liner scale, logarithmic scale
Peak value display	Off, maximal, maximum
Averaging	Simple average, exponential average, peak hold (the number of sampling points can be specified from 2 to 10,000)
Calculation execution button	The [Execute] button is displayed on the screen.

Memory division

Maximum division number	1,024 blocks
Block search	The instrument can search through data stored divided memory blocks.
Batch save	The instrument saves previously measured data that has been recorded in all blocks in one operation.

Waveform search

Search method	<p>Peak Maximum, minimum, maximal, minimal</p> <p>Trigger Level, window-in, window-out Logic trigger points can be searched for when the target channel is set to the logic channels. No logic trigger points cannot searched for when the envelope is used.</p> <p>Concierge Histogram, standard deviation (For each of them, a target for comparison can be chosen between the fundamental waveform and the previously observed waveform.) The concierge function cannot be used when the envelope is used.</p> <p>Jump Event mark, cursor, time (specified using an absolute time, a relative time, or the number of points), trigger point, search mark.</p>
Scope of search	All: All data stored in the internal memory Specified segment: Either one of the areas specified by [Segment 1] or [Segment 2] is chosen.
Number of search results	Up to 1000 points can be specified.
Continuous search	When the scope of search is found to include retrieved data points more than the specified number after the search, the instrument can continuously search waveform data points after the last retrieved data point.
Display method	A retrieved data point can be displayed by specifying its position.

Others

Auto-setup	Available The instrument loads settings data previously saved (STARTUP.SET) at turn-on and starts up. The instrument searches the following locations for the settings data (in this order): HDD/SSD, SD memory card, and USB flash drive.
Rotary knob	X: The horizontal manipulations are available: changing the sampling rate, magnification/demagnification ratio, and display positions and moving cursors. Y: The vertical manipulations are available: switching the measurement ranges, changing the magnification/demagnification ratio and display positions, and moving cursors.
Shortcut keys	The S1 key and the S2 key: Functions can be assigned.
Auto-range	Available The instrument automatically configures appropriate settings that include the sampling rate and measurement range depending on input waveforms. (Not available when the envelope, real-time save, or external sampling is used.)

Key lock	Three permission levels are available: <ul style="list-style-type: none"> • ALL (Touch panel operation and key operation are disabled.) • TOUCH PANEL (Only touch panel operation is disabled.) • OFF (The key lock is disengaged.)
Beep sound	Three conditions are available: <ul style="list-style-type: none"> • Off • Alert • Alert + action
Email transmission	Email transmission function using SMTP When to send an email: when data is automatically saved; when data is saved by pressing the SAVE key Contents: An email includes the text entered in the Body box with a file in the format specified in the Type box attached.
Initialization	Discarding the existing waveform data, restoring the settings to the initial values, initializing the instrument
Self-check	Memory check, touch panel check, key check, LCD check, LAN check, storage device check
Language	English, Japanese, Chinese
Error indication Warning indication	The instrument displays details of an error or warning.
Touch keyboard	The instrument displays the keyboard on the screen.
Region-specific setting	Choose characters that represent the decimal point and the separator used in waveform files (text format) and numerical calculation result files. Decimal point: period, comma Separator: comma, space, tab, semicolon
Time value display	Time, time in sexagesimal, date, the number of data points
Zero position display	On/Off
Waveform screen background color	Black or white
Restart permission	Permitted or prohibited Permitted: When a setting is changed during a measurement, another measurement starts. Prohibited: Changing any settings are prohibited during measurement.
Display setting	Brightness can be adjusted. Automatic power-off can be set for the display.
Time setting	A date and time can be set.
System protection	On/Off The system is protected against an unexpected shutdown. However, it is recommended disengaging the system protection and supplying the power from an external UPS for long-term continuous operation.
Number of current sensors to be connected	Up to nine sensors can connect to Model Z5021 Probe Power Unit, Model 8971 Current Unit, and Model U8977 3CH Current Unit in total.
Limitation of the number of modules	Model 8971 Current Unit: Up to four slots Model U8977 3CH Current Unit: Up to three slots

5.2 Specifications of the Options

Model Z5021 Probe Power Unit

Conditions of guaranteed accuracy

Specified, unless otherwise designated, at 23°C ±5°C (73°F ±9°F) and 80% RH or less.

Supported probe	Model CT6700 Current Probe Model CT6701 Current Probe Model 3273-50 Clamp on Probe Model 3274 Clamp on Probe Model 3275 Clamp on Probe Model 3276 Clamp on Probe
Number of terminals	8
Operating environment	Indoors, Pollution Degree 2, Operating altitude: up to 2000 m (6562 ft.)
Operating temperature and humidity	0°C to 40°C (32°F to 104°F), 80% RH or less (no condensation)
Storage temperature and humidity	-10°C to 50°C (14°F to 122°F), 80% RH or less (no condensation)
Standards	Safety: EN 61010 EMC: EN 61326 Class A
Product warranty period	3 years
Output voltage	±12 V DC ±0.5 V DC
Rated output current	±0.6 A (for each terminal)
Ripple voltage	200 mV p-p or less (at rated output current)

Model U8332 SSD Unit

Recording capacity	256 GB (MLC)
Supported interface standard	Serial ATA Revision 3.0 compatible (2.5-inch)
Operating temperature and humidity	Consistent with the specifications of Memory HiCorder in which Model U8332 is installed.
Storage temperature and humidity	Consistent with the specifications of Memory HiCorder in which Model U8332 is installed.

Model U8333 HD Unit

Recording capacity	320 GB
Supported interface standard	Serial ATA Revision 2.0 compatible (2.5-inch)
Operating temperature and humidity	Consistent with the specifications of Memory HiCorder in which Model U8333 is installed.
Storage temperature and humidity	Consistent with the specifications of Memory HiCorder in which Model U8333 is installed.

Model 8966 Analog Unit

Conditions of guaranteed accuracy

Specified under the following conditions: installed in a Memory HiCorder and operated at 23°C ±5°C (73°F ±9°F) in the range of 20% to 80% RH after a half-hour (at least) warm-up and execution of zero-adjustment.

Product warranty period	3 years
Guaranteed accuracy period	1 year
Number of input channels	2 channels
Measurement range	100, 200, 400 mV f.s., 1, 2, 4, 10, 20, 40, 100, 200, 400 V f.s.
Measurement accuracy	±0.5% f.s. (with the filter set at 5 Hz)
Temperature characteristics	±0.06% f.s./°C
Frequency characteristics	DC to 5 MHz -3 dB (DC-coupled) 7 Hz to 5 MHz -3 dB (AC-coupled, at a lower cutoff frequency of 7 Hz ±50%)
Noise	1.5 mV p-p (typ.), 2 mV p-p (max.); with the highest sensitivity range and the terminals of each input connector connected with each other
Common-mode rejection ratio	80 dB or more (at 50 Hz / 60 Hz, a signal source resistance of 100 Ω or less)
Low-pass filter	Off, 5 ±50%, 50 ±50%, 500 ±50%, 5 k ±50%, 50 k ±50%, 500 k ±50% (Hz) -3 dB
Input type	Unbalanced input (floating)
Input coupling	AC/DC/GND
Input resistance	1 MΩ ±1%
Input capacitance	30 pF ±10 pF (at 100 kHz)
A/D resolution	12 bits
Maximum sampling rate	20 MS/s
Input terminals	Insulated BNC terminal
Maximum input voltage	400 V DC

Maximum rated voltage to earth	300 V AC, DC (between each input channel and the enclosure, between any two of input channels) Measurement category II, anticipated transient overvoltage: 2500 V
Operating temperature and humidity	Consistent with the specifications of the Memory HiCorder in which Model 8966 is installed.
Operating environment	Consistent with the specifications of the Memory HiCorder in which Model 8966 is installed.
Storage temperature and humidity	-10°C to 50°C (14°F to 122°F), 80% RH or less (no condensation)
Dimensions	Approx. 106W × 19.8H × 196.5D mm (4.17"W × 0.78"H × 7.74"D)
Mass	Approx. 250 g (8.8 oz.)
Effect of radiated radio-frequency electromagnetic field	±15% f.s. (max.) at 3 V/m
Effect of conducted radio-frequency electromagnetic field	±45% f.s. (max.) at 3 V (with the 2 V f.s. range, with 1 V DC inputted)
Standards	Safety: EN61010 EMC: EN61326 Class A

Model 8967 Temp Unit

Conditions of guaranteed accuracy

Specified under the following conditions: installed in a Memory HiCorder and operated at $23^{\circ}\text{C} \pm 5^{\circ}\text{C}$ ($73^{\circ}\text{F} \pm 9^{\circ}\text{F}$) in the range of 20% to 80% RH after a half-hour (at least) warm-up and execution of zero-adjustment.

Product warranty period	3 years
Guaranteed accuracy period	1 year
Number of input channels	2 channels
Input terminals	Push-button type terminal block (2 terminals/channel)
Measurement target	Thermocouple (K, J, E, T, N, R, S, B, W)
Reference junction compensation accuracy	$\pm 1.5^{\circ}\text{C}$ (When the reference junction compensation is set to internal, add this value to the accuracy of thermocouple measurement.)
Reference junction compensation	Switchable between internal or external (for temperature measurement with thermocouples)
Temperature characteristics	Add [(measurement accuracy) \times 0.1] $^{\circ}\text{C}$ to the measurement accuracy.
Data refresh	The data refresh rate can be switched. Fast: Approx. 1.2 ms Normal: Approx. 100 ms Slow: Approx. 500 ms
Wire break detection	Switchable between on and off
Input resistance	5 M Ω or more (regardless of the wire break detection setting)
Common-mode rejection ratio	80 dB or more (at 50 Hz / 60 Hz, for a signal source resistance of 100 Ω or less, with the data refresh set to Fast) 100 dB or more (at 50 Hz / 60 Hz, for a signal source resistance or 100 Ω or less, with the data refresh set to Normal)
Input type	Unbalanced input (floating)
Maximum rated voltage to earth	300 V AC, DC (between each input channel and the enclosure, between any two of input channels) Measurement category II, anticipated transient overvoltage: 2500 V
Operating temperature and humidity	Consistent with the specifications of the Memory HiCorder in which Model 8967 is installed.
Storage temperature and humidity	-20°C to 50°C (-4°F to 122°F), 90% RH or less (no condensation)
Operating environment	Consistent with the specifications of the Memory HiCorder in which Model 8967 is installed.
Dimensions	Approx. 106W \times 19.8H \times 204.5D mm (4.17"W \times 0.78"H \times 8.05"D)
Mass	Approx. 240 g (8.5 oz.)
Effect of radiated radio-frequency electromagnetic field	$\pm 2\%$ f.s. (max.) at 3 V/m

Effect of conducted radio-frequency electromagnetic field $\pm 2\%$ f.s. (max.) at 3 V

Standards Safety: EN61010
EMC: EN61326 Class A

Accessories Ferrite clamp-on choke $\times 2$

Options Model 9810 Thermocouple (K)

Table: Measurable ranges, resolutions, and measurement accuracy of each thermocouple type and measurement range

Measurement target	Measurement range	Measurable range	Resolution	Measurement accuracy	
Thermocouple* ¹	K* ²	200°C f.s.	-100°C to 200°C	0.01°C	$\pm 0.1\%$ f.s. $\pm 1^\circ\text{C}$ (0°C or higher)
		1000°C f.s.	-200°C to 1000°C	0.05°C	
		2000°C f.s.	-200°C to 1350°C	0.1°C	
	J* ²	200°C f.s.	-100°C to 200°C	0.01°C	$\pm 0.1\%$ f.s. $\pm 2^\circ\text{C}$ (-200°C or higher but lower than 0°C)
		1000°C f.s.	-200°C to 1000°C	0.05°C	
		2000°C f.s.	-200°C to 1100°C	0.1°C	
	E* ²	200°C f.s.	-100°C to 200°C	0.01°C	
		1000°C f.s.	-200°C to 800°C	0.05°C	
		2000°C f.s.	-200°C to 800°C	0.1°C	
	T* ²	200°C f.s.	-100°C to 200°C	0.01°C	
		1000°C f.s.	-200°C to 400°C	0.05°C	
		2000°C f.s.	-200°C to 400°C	0.1°C	
	N* ²	200°C f.s.	-100°C to 200°C	0.01°C	
		1000°C f.s.	-200°C to 1000°C	0.05°C	
		2000°C f.s.	-200°C to 1300°C	0.1°C	
	R* ²	200°C f.s.	0°C to 200°C	0.01°C	$\pm 0.1\%$ f.s. $\pm 3.5^\circ\text{C}$ (0°C or higher but lower than 400°C) (For Type B, accuracy is not guaranteed below 400°C.)
		1000°C f.s.	0°C to 1000°C	0.05°C	
		2000°C f.s.	0°C to 1700°C	0.1°C	
	S* ²	200°C f.s.	0°C to 200°C	0.01°C	$\pm 0.1\%$ f.s. $\pm 3^\circ\text{C}$ (400°C or higher)
		1000°C f.s.	0°C to 1000°C	0.05°C	
		2000°C f.s.	0°C to 1700°C	0.1°C	
B* ²	1000°C f.s.	400°C to 1000°C	0.05°C		
	2000°C f.s.	400°C to 1800°C	0.1°C		
W* ³ (WRe5-26)	200°C f.s.	0°C to 200°C	0.01°C		
	1000°C f.s.	0°C to 1000°C	0.05°C		
	2000°C f.s.	0°C to 2000°C	0.1°C		

*1: Not including reference junction compensation accuracy

*2: JIS C 1602-1995

*3: ASTM E-988-96

Model 8968 High Resolution Unit

Conditions of guaranteed accuracy

Specified under the following conditions: installed in a Memory HiCorder and operated at 23°C ±5°C (73°F ±9°F) in the range of 20% to 80% RH after a half-hour (at least) warm-up and execution of zero-adjustment.

Product warranty period	3 years
Guaranteed accuracy period	1 year
Number of input channels	2 channels
Measurement range	100, 200, 400 mV f.s., 1, 2, 4, 10, 20, 40, 100, 200, 400 V f.s.
Measurement accuracy	±0.3% f.s. (with the filter setting set at 5 Hz, operated after zero-adjustment)
Temperature characteristics	±0.045% f.s./°C
Frequency characteristics	DC to 100 kHz -3 dB (DC-coupled) 7 Hz to 100 kHz -3 dB (AC-coupled, at a lower cutoff frequency of 7 Hz ±50%)
Noise	500 µV p-p (typ.), 1 mV p-p (max.) (with the highest sensitivity range and the terminals of each input connector connected with each other)
Common-mode rejection ratio	80 dB or more (at 50 Hz / 60 Hz, a signal source resistance of 100 Ω or less)
Low-pass filter	Off, 5 ±50%, 50 ±50%, 500 ±50%, 5 k ±50%, 50 k ±50% (Hz) -3 dB
Anti-aliasing filters	Cutoff frequency (fc): 20, 40, 80, 200, 400, 800, 2 k, 4 k, 8 k, 20 k, 40 k (Hz) (Automatically set when the anti-aliasing filter is on.) Attenuation property: -66 dB or higher at a frequency of 1.5 fc
Input type	Unbalanced input (floating)
Input coupling	AC/DC/GND
Input resistance	1 MΩ ±1%
Input capacitance	30 pF ±10 pF (at 100 kHz)
A/D resolution	16 bits
Maximum sampling rate	1 MS/s
Input terminals	Insulated BNC terminal
Maximum input voltage	400 V DC
Maximum rated voltage to earth	300 V AC, DC (between each input channel and the enclosure, between any two of input channels) Measurement category II, anticipated transient overvoltage: 2500 V
Operating temperature and humidity	Consistent with the specifications of the Memory HiCorder in which Model 8968 is installed.
Operating environment	Consistent with the specifications of the Memory HiCorder in which Model 8968 is installed.
Storage temperature and humidity	-10°C to 50°C (14°F to 122°F), 80% RH or less (no condensation)
Dimensions	Approx. 106W × 19.8H × 196.5D mm (4.17"W × 0.78"H × 7.74"D)
Mass	Approx. 250 g (8.5 oz.)

Effect of radiated radio-frequency electromagnetic field	±15% f.s. (max.) at 3 V/m
Effect of conducted radio-frequency electromagnetic field	±20% f.s. (max.) at 3 V (with the 2 V f.s. range, with 1 V DC inputted)
Standards	Safety: EN61010 EMC: EN61326 Class A

Model U8969 Strain Unit

Conditions of guaranteed accuracy

Specified under the following conditions: installed in a Memory HiCorder and operated at 23°C ±5°C (73°F ±9°F) and 80% RH or less after a half-hour (at least) warm-up and execution of the auto-balance.

Operating environment	Indoors, Pollution Degree 2, Operating altitude: up to 2000 m (6562 ft.)
Operating temperature and humidity	-10°C to 40°C (14°F to 104°F), 80% RH or less (no condensation)
Storage temperature and humidity	-20°C to 50°C (-4°F to 122°F), 90% RH or less (no condensation)
Standards	Safety: EN 61010 EMC: EN 61326 Class A
Dimensions	Approx. 106W × 19.8H × 196.5D mm (4.17"W × 0.78"H × 7.74"D)
Mass	Approx. 245 g (8.6 oz.)
Product warranty period	3 years
Guaranteed accuracy period	1 year
Guaranteed accuracy period after adjustment made by Hioki	1 year
Accessories	Model L9769 Conversion Cable ×2 (Compatible connector: NDIS connector PRC03-12A10-7M10.5)
Number of input channels	2 channels
Input terminals	NDIS connector EPRC07-R9FNDIS
Measurement target	Strain gauge transducer
Gauge ratio	2.0
Bridge voltage	2 V ±0.05 V
Bridge resistor	120 Ω to 1 kΩ
Balance adjustment range	±10000 με or lower
Balancing method	Electronic auto-balancing
Measurement range	400, 1000, 2000, 4000, 10000, 20000 με f.s.
Frequency characteristics	DC to 20 kHz, +1/-3 dB
A/D resolution	16 bits (± f.s. = ±25000 data points)
Maximum sampling rate	200 kS/s
Maximum rated voltage to earth	30 V rms AC or 60 V DC (between each input channel and the enclosure, between any two of input channels) Anticipated transient overvoltage: 330 V
Measurement accuracy	±0.5% f.s. ±4 με (with the filter set at 5 Hz)
Temperature characteristics	Gain: ±0.05% f.s./°C Zero position: ±2.5 με/°C

Effect of radiated radio-frequency electromagnetic field	$\pm 10\%$ f.s. (max.) at 3 V/m (with the filter set at 5 Hz)
Effect of conducted radio-frequency electromagnetic field	$\pm 10\%$ f.s. (max.) at 3 V (with the filter set at 5 Hz)
Low-pass filter	Off, 5 $\pm 30\%$, 10 $\pm 30\%$, 100 $\pm 30\%$, 1 k $\pm 30\%$ (Hz) -3 dB

Model 8970 Freq Unit

Conditions of guaranteed accuracy

Specified under the following conditions: installed in a Memory HiCorder and operated at 23°C ±5°C (73°F ±9°F) in the range of 20% to 80% RH and operated after a half-hour (at least) warm-up.

Product warranty period	3 years
Guaranteed accuracy period	1 year
Measurement functions	The following types of measurement based on voltage input: frequency, rotation speed, power frequency, count, pulse duty ratio, and pulse width
Input terminals	Insulated BNC terminal
Input resistance	1 MΩ ±1%
Input capacitance	30 pF ±10 pF
Maximum input voltage	400 V DC
Maximum rated voltage to earth	300 V AC, DC (Measurement category II) Anticipated transient overvoltage: 2500 V (between each input channel and the enclosure, between any two of input channels)
Input type	Unbalanced input (floating)
Frequency mode	Measurement range: 20, 100, 200 Hz, 1, 2, 10, 20, 100 kHz f.s. Measurement accuracy: ±0.1% f.s. (except for the 100 kHz range) ±0.7% f.s. (the 100 kHz range) Measurable range: DC to 100 kHz (minimum pulse width: 2 μs)
Rotation speed mode	Measurement range: 2 k, 10 k, 20 k, 100 k, 200 k, 1 M, 2 Mr/min f.s. Measurement accuracy: ±0.1% f.s. (except for the 2 Mr/min range) ±0.7% f.s. (the 2 Mr/min range) Measurable range: 0 Mr/min to 2 Mr/min (minimum pulse width: 2 μs)
Power frequency mode	Measurement range: 50 Hz (40 Hz to 60 Hz), 60 Hz (50 Hz to 70 Hz), 400 Hz (390 Hz to 410 Hz) Measurement accuracy: ±0.03 Hz (50 Hz, 60 Hz), ±0.1 Hz (400 Hz)
Accumulation mode	Measurement range: 40 k, 200 k, 400 k, 2 M, 4 M, 20 M counts f.s. Measurement accuracy: 0.0025% f.s. Measurable range: DC to 100 kHz (minimum pulse width: 2 μs)
Duty ratio mode	Measurement range: 100% f.s. Measurement accuracy: ±1% (10 Hz to 10 kHz) ±4% (10 kHz to 100 kHz) Measurable range: 10 Hz to 100 kHz (minimum pulse width: 2 μs)
Pulse width mode	Measurement range: 10 ms, 20 ms, 100 ms, 200 ms, 1 s, 2 s f.s. Measurement accuracy: ±0.1% f.s. Measurable range: 2 μs to 2 s
Measurement resolution	0.0025% f.s. (accumulation mode) 0.01% f.s. (except for accumulation mode or power frequency mode) 0.01 Hz (power frequency mode)
Response time	Within the sum of 40 μs and the sampling interval of the instrument in which the module is installed
Input voltage range	±10 V, ±20 V, ±50 V, ±100 V, ±200 V, ±400 V

Threshold value	<p>±10 V range: Variable in the range of –10 V to +10 V (in 0.1 V increments)</p> <p>±20 V range: Variable in the range of –20 V to +20 V (in 0.2 V increments)</p> <p>±50 V range: Variable in the range of –50 V to +50 V (in 0.5 V increments)</p> <p>±100 V range: Variable in the range of –100 V to +100 V (in 1 V increments)</p> <p>±200 V range: Variable in the range of –200 V to +200 V (in 2 V increments)</p> <p>±400 V range: Variable in the range of –400 V to +400 V (in 5 V increments)</p>
Slope	Rising, falling (frequency mode, rotation speed mode, power frequency mode, accumulation mode)
Level	High, low (duty ratio mode, pulse width mode)
Hold	<p>Frequency mode, rotation speed mode: On, Off (1 Hz, 0.5 Hz, 0.2 Hz, 0.1 Hz)</p> <p>Operation with Off: When the instrument cannot determine a subsequent measured value while the waiting time (period) elapses, the instrument calculates a frequency and rotation speed based on the time interval between the time when previously determining measured value and the time when sampling the data, and records these calculated values. When these calculated values are less than user-defined values, then the values will be assumed to be zero.</p>
Smoothing	<p>Off, On (frequency mode, rotation speed mode)</p> <p>The permissible smoothing frequency is up to 10 kHz.</p>
Low-pass filter	Off, 5, 50, 500, 5 k, 50 k (Hz)
Input coupling	DC, AC (Lower cutoff frequency in AC-coupled mode: 7 Hz)
Frequency division function	Setting range: 1 to 4096, in one increments (frequency mode, rotation speed mode, accumulation mode)
Accumulation start timing	Start, trigger (accumulation mode)
Process performed when accumulation overflows	Hold, back (accumulation mode)
Operating temperature and humidity	Consistent with the specifications of the Memory HiCorder in which Model 8970 is installed.
Operating environment	Consistent with the specifications of the Memory HiCorder in which Model 8970 is installed.
Storage temperature and humidity	Consistent with the specifications of the Memory HiCorder in which Model 8970 is installed.
Standards	<p>Safety: EN61010</p> <p>EMC: EN61326 Class A</p>
Dimensions	Approx. 106W × 19.8H × 196.5D mm (4.17"W × 0.78"H × 7.74"D)
Mass	Approx. 250 g (8.8 oz.)

Model 8971 Current Unit

Conditions of guaranteed accuracy

Specified under the following conditions: installed in a Memory HiCorder and operated at 23°C ±5°C (73°F ±9°F) in the range of 20% to 80% RH after a half-hour (at least) warm-up and execution of zero-adjustment.

Product warranty period	3 years
Guaranteed accuracy period	1 year
Number of input channels	2 channels
Supported current sensors	Models 9272-10, 9709, CT6841, CT6843, CT6844, CT6845, CT6846, CT6862, CT6863, CT6865* ² Hioki current sensors with RM515EPA-10PC (Hirose connector) installed (Supported conversion ratio: 2 V/20 A, 2 V/50 A, 2 V/200 A, 2 V/500 A, 2 V/1000 A* ² , 2 V/1000 A* ²) (Each sensor requires Model 9318 Conversion Cable to connect with Model 8971 Current Unit)
Measurement range	When Model 9272-10 (20 A), Model 9277, or Model CT6841 is used 2, 4, 10, 20, 40, 100 A f.s. When Model CT6862 is used 4, 10, 20, 40, 100, 200 A f.s. When Model 9272-10 (200 A), Model 9278, Model CT6863, or Model CT6863 is used 20, 40, 100, 200, 400, 1000 A f.s. When Model 9279, Model 9709, Model CT6844, Model CT6845, Model CT6846* ² , or Model CT6865* ² is used 40, 100, 200, 400, 1000, 2000 A f.s.
Measurement accuracy*¹	±0.65% f.s. (with the filter set at 5 Hz) ±0.85% f.s. (with the filter set at 5 Hz) when Model 9278 or Model 9279 is used.
RMS accuracy*¹	±1% f.s. (DC, 30 Hz to 1 kHz) ±3% f.s. (1 kHz to 10 kHz) (Sine wave input, with the filter set at 5 Hz, crest factor: 2)
Response time*¹	100 ms (rising from 0% of f.s. to 90% of f.s.)
Temperature characteristics*¹	±0.075% f.s./°C
Frequency characteristics*¹	DC to 100 kHz ±3 dB (DC-coupled) 7 Hz to 100 kHz ±3 dB (AC-coupled, at a lower cutoff frequency of 7 Hz ±50%)
Noise*¹	10 mA p-p (max.), with the highest sensitivity range and the terminals of each input connector connected with each other (for 20 A/2 V range)
Low-pass filter	Off, 5 ±50%, 50 ±50%, 500 ±50%, 5 k ±50%, 50 k ±50% (Hz) -3 dB
Input type	Unbalanced input (Not isolated)
Input coupling	AC/DC/GND
Input resistance	1 MΩ ±1%
A/D resolution	12 bits
Maximum sampling rate	1 MS/s
Input terminals	Sensor connector HR10A-10R-S (Hirose connector)
Operating temperature and humidity	Consistent with the specifications of the Memory HiCorder in which Model 8971 is installed.
Operating environment	Consistent with the specifications of the Memory HiCorder in which Model 8971 is installed.

Storage temperature and humidity	-10°C to 50°C (14°F to 122°F), 80% RH or less (no condensation)
Dimensions	Approx. 106W × 19.8H × 196.5D mm (4.17"W × 0.78"H × 7.74"D)
Mass	Approx. 250 g (8.8 oz.)
Standards	Safety: EN61010 EMC: EN61326 Class A
Accessories	Model 9318 Conversion Cable ×2 (for connecting current sensors)
Number of installable modules	Up to four modules

*1: For current measurement, add accuracy and characteristics of a current sensor

*2: Since the instrument recognizes these sensors as a sensor that has a conversion ratio of 2 V/500 A, the scaling conversion ratio shall be set at 2.

Model 8972 DC/RMS Unit

Conditions of guaranteed accuracy

Specified under the following conditions: installed in a Memory HiCorder and operated at 23°C ±5°C (73°F ±9°F) in the range of 20% to 80% RH after a half-hour (at least) warm-up and execution of zero-adjustment.

Product warranty period	3 years
Guaranteed accuracy period	1 year
Number of input channels	2 channels
Measurement range	100, 200, 400 mV f.s. 1, 2, 4, 10, 20, 40, 100, 200, 400 V f.s.
Measurement accuracy	±0.5% f.s. (with the filter set at 5 Hz)
RMS accuracy	±1% f.s. (DC, 30 Hz to 1 kHz) ±3% f.s. (1 kHz to 100 kHz) (Sine wave input, response time setting: Slow)
Response time	Slow: 5 s (rising from 0% of f.s. to 90% of f.s.) Normal: 800 ms (rising from 0% of f.s. to 90% of f.s.) Fast: 100 ms (rising from 0% of f.s. to 90% of f.s.)
Crest factor	2
Temperature characteristics	±0.045% f.s./°C
Frequency characteristics	DC to 400 kHz: -3 dB (DC-coupled) 7 Hz to 400 kHz: -3 dB (AC-coupled, at a lower cutoff frequency of 7 Hz ±50%)
Noise	500 µV p-p (typ.), 750 µV p-p (max.), with the highest sensitivity range and the terminals of each input connector connected with each other
Common-mode rejection ratio	80 dB or more (at 50 Hz / 60 Hz, a signal source resistance of 100 Ω or less)
Low-pass filter	Off, 5 ±50%, 50 ±50%, 500 ±50%, 5 k ±50%, 100 k ±50% (Hz) -3 dB
Input type	Unbalanced input (floating)
Input coupling	AC/DC/GND
Input resistance	1 MΩ ±1%
Input capacitance	30 pF ±10 pF (at 100 kHz)
A/D resolution	12 bits
Maximum sampling rate	1 MS/s
Input terminals	Insulated BNC terminal
Maximum input voltage	400 V DC
Maximum rated voltage to earth	300 V AC, DC (between each input channel and the enclosure, between any two of input channels) Measurement category II, anticipated transient overvoltage: 2500 V
Operating temperature and humidity	Consistent with the specifications of the Memory HiCorder in which Model 8972 is installed
Operating environment	Consistent with the specifications of the Memory HiCorder in which Model 8972 is installed
Storage temperature and humidity	-10°C to 50°C (14°F to 122°F), 80% RH or less (no condensation)

Dimensions	Approx. 106W × 19.8H × 196.5D mm (4.17"W × 0.78"H × 7.74"D)
Mass	Approx. 250 g (8.6 oz.)
Effect of radiated radio-frequency electromagnetic field	±15% f.s. (max.) at 3 V/m
Effect of conducted radio-frequency electromagnetic field	±20% f.s. (max.) at 3 V (with the 2 V f.s. range, with 1 V DC inputted)
Standards	Safety: EN61010 EMC: EN61326 Class A

Model 8973 Logic Unit

Product warranty period	3 years
Number of input channels	4 probes (16 channels)
Input terminals	Mini DIN
Supported probes	Model 9320-01 Logic Probe, Model MR9321-01 Logic Probe, Model 9327 Logic Probe
Operating temperature and humidity	Consistent with the specifications of the Memory HiCorder in which Model 8973 is installed.
Operating environment	Consistent with the specifications of the Memory HiCorder in which Model 8973 is installed.
Storage temperature and humidity	-20°C to 50°C (-4°F to 122°F), 80% RH or less (no condensation)
Dimensions	Approx. 106W × 19.8H × 196.5D mm (4.17"W × 0.78"H × 7.74"D)
Mass	Approx. 190 g (6.7 oz.)
Standards	Safety: EN61010 EMC: EN61326 Class A

Model MR8990 Digital Voltmeter Unit

Conditions of guaranteed accuracy

Specified under the following conditions: installed in a Memory HiCorder and operated at 23°C ±5°C (73°F ±9°F) in the range of 20% to 80% RH after a half-hour (at least) warm-up and execution of calibration.

Product warranty period	3 years
Guaranteed accuracy period	1 year
Number of input channels	2 channels
Measurement item	DC voltage

Measurement range	Measurement range			Input resistance
	Measurement range	Effective input range*	Maximum resolution	
	100 mV f.s.	-120 mV to 120 mV	0.1 µV	100 MΩ or more
	1 V f.s.	-1200 mV to 1200 mV	1 µV	
	10 V f.s.	-12 V to 12 V	10 µV	
	100 V f.s.	-120 V to 120 V	100 µV	10 MΩ ±5%
	1000 V f.s.	-500 V to 500 V	1 mV	

*: Guaranteed range of measurement accuracy

Measurement accuracy	Measurement range	NPLC: Less than 1	NPLC: 1 or more
	100 mV f.s.	±0.01% rdg. ±0.015% f.s.	±0.01% rdg. ±0.01% f.s.
	1 V f.s.	±0.01% rdg. ±0.0025% f.s.	
	10 V f.s.		
	100 V f.s.	±0.025% rdg. ±0.0025% f.s.	
1000 V f.s.			
Temperature characteristics	±(0.002% rdg. + 0.00025% f.s.)/°C		
A/D conversion measurement method	Delta-sigma modulation method		
Integration time	Power frequency	Integration time	
	50 Hz	20 ms × NPLC	
	60 Hz	16.67 ms × NPLC	
	NPLC: Settable from 0.1 to 0.9 (in 0.1 increments), 1 to 9 (in one increments), and 10 to 100 (in 10 increments)		
Response time	Within [2 ms + 2 × (integration time)] (rising from – f.s. to +f.s., and falling from +f.s. to –f.s.)		
High-speed response	On/Off		
Common-mode rejection ratio	100 dB or more (at 50 Hz / 60 Hz, a signal source resistance of 100 Ω or less)		
Input type	Unbalanced input (floating)		
Input terminals	Banana jacks		
Maximum input voltage	500 V DC		
Maximum rated voltage to earth	300 V AC, DC (between each input channel and the enclosure, between any two of input channels) Measurement category II, anticipated transient overvoltage: 2500 V		
Operating temperature and humidity	Consistent with the specifications of Memory HiCorder in which Model MR8990 is installed.		
Operating environment	Consistent with the specifications of Memory HiCorder in which Model MR8990 is installed.		
Storage temperature and humidity	–10°C to 50°C (14°F to 122°F), 80% RH or less (no condensation)		
Dimensions	Approx. 106W × 19.8H × 196.5D mm (4.17"W × 0.78"H × 7.74"D)		
Mass	Approx. 260 g (6.7 oz.)		
Effect of radiated radio-frequency electromagnetic field	±0.1% f.s. (max.) at 3 V/m (with the 100 mV f.s. range)		
Standards	Safety: EN61010 EMC: EN61326 Class A		
Options	Model L2200 Test Lead		

Model U8974 High Voltage Unit

Conditions of guaranteed accuracy

Specified under the following conditions: installed in a Memory HiCorder and operated at 23°C ±5°C (73°F ±9°F) in the range of 20% to 80% RH after a half-hour (at least) warm-up and execution of zero-adjustment.

Product warranty period	3 years
Guaranteed accuracy period	1 year
Number of input channels	2 channels
Measurement functions	Instantaneous value, RMS value (Each channel can have a different setting.)
Measurement range	4, 10, 20, 40, 100, 200, 400, 1000 V f.s. (DC mode) 10, 20, 40, 100, 200, 400, 1000 V f.s. (RMS mode)
Measurement accuracy	±0.25% f.s. (with the filter set at 5 Hz)
RMS measurement accuracy	±1.5% f.s. (DC, 30 Hz or higher but lower than 1 kHz, sine wave, response time: slow) ±3% f.s. (1 kHz to 10 kHz, sine wave) Crest factor: 2 (sine wave, a peak voltage of up to 1000 V)
RMS measurement response time	Fast: 150 ms (rising from 0% of f.s. to 90% of f.s.) Normal: 500 ms (rising from 0% of f.s. to 90% of f.s.) Slow: 2.5 s (rising from 0% of f.s. to 90% of f.s.)
Temperature characteristics	±0.05% f.s./°C
Frequency characteristics	DC to 100 kHz, -3 dB
Noise	30 mV p-p (typ.), 50 mV p-p (max.), with the highest sensitivity range and the terminals of each input connector connected with each other
Common-mode rejection ratio	80 dB or more (at 50 Hz / 60 Hz, with input terminals connected with each other)
Low-pass filter	Off, 5 ±50%, 50 ±50%, 500 ±50%, 5 k ±50%, 50 k ±50% (Hz) -3 dB
Input type	Balanced input (floating)
Input coupling	DC/GND
Input resistance	4 MΩ ±1%
Input capacitance	5 pF or less (at 100 kHz)
A/D resolution	16 bits
Maximum sampling rate	1 MS/s
Input terminals	Banana jacks
Maximum input voltage	1000 V DC, 700 V AC
Maximum rated voltage to earth	1000 V AC, DC, Measurement category III; 600 V AC, DC, Measurement category IV (between each input channel and the enclosure, between any two of input channels) Anticipated transient overvoltage: 8000 V
Operating temperature and humidity	Consistent with the specifications of Memory HiCorder in which Model U8974 is installed.
Operating environment	Consistent with the specifications of Memory HiCorder in which Model U8974 is installed.

Storage temperature and humidity	-20°C to 50°C For -20°C or higher but lower than 40°C (-4°F or higher but lower than 104°F), 80% RH or less (no condensation) For 40°C or higher but lower than 45°C (104°F or higher but lower than 113°F), 60% RH or less (no condensation) For 45°C to 50°C (113°F to 122°F), 50% RH or less (no condensation)
Dimensions	Approx. 106W × 19.8H × 196.5D mm (4.17"W × 0.78"H × 7.74"D)
Mass	Approx. 230 g (8.1 oz.)
Effect of radiated radio-frequency electromagnetic field	±5% f.s. (max.) at 3 V/m
Effect of conducted radio-frequency electromagnetic field	±5% f.s. (max.) at 3 V (with the 10 V f.s. range, with 1 V DC inputted)
Standards	Safety: EN61010 EMC: EN61326 Class A
Options	Model L4940 Connection Cable Set (1.5 m) Model L4935 Alligator Clip Set (attached to the tips of Model L4940, CAT IV 600 V, CAT III 1000 V) Model 9243 Grabber Clip (attached to the tips of Model L4940, CAT III 1000 V) Model L4936 Bus Bar Clip Set (attached to the tips of Model L4940, CAT III 600 V) Model L4937 Magnetic Adapter Set (attached to the tips of Model L4940, CAT III 1000 V) Model L4931 Extension Cable Set (to extend the length of Model L4940, 1.5 m) Model L4932 Test Pin Set (attached to the tips of Model L4940, CAT IV 600 V, CAT III 1000 V) Model L4934* Small Alligator Clip Set (CAT III 300 V, CAT II 600 V) *: Model L4932 is required when Model L4934 is used.

Model U8975 4ch Analog Unit

Conditions of guaranteed accuracy

Specified under the following conditions: installed in a Memory HiCorder and operated at $23^{\circ}\text{C} \pm 5^{\circ}\text{C}$ ($73^{\circ}\text{F} \pm 9^{\circ}\text{F}$) and 80% RH or less after a half-hour (at least) warm-up and execution of zero-adjustment.

Operating environment	Indoors, Pollution Degree 2, Operating altitude: up to 2000 m (6562 ft.)
Operating temperature and humidity	0°C to 40°C (32°F to 104°F), 80% RH or less (no condensation)
Storage temperature and humidity	-10°C to 50°C For -10°C or higher but lower than 40°C (14°F or higher but lower than 104°F), 80% RH or less (no condensation) For 40°C or higher but lower than 45°C (104°F or higher but lower than 113°F), 60% RH or less (no condensation) For 45°C to 50°C (113°F to 122°F), 50% RH or less (no condensation)
Standards	Safety: EN61010 EMC: EN61326 Class A
Dimensions	Approx. 106W × 19.8H × 196.5D mm (4.17"W × 0.78"H × 7.74"D)
Mass	Approx. 250 g (8.8 oz.)
Product warranty period	3 years
Measurement range	4, 10, 20, 40, 100, 200 V f.s.
Maximum input voltage	200 V DC
Maximum rated voltage to earth	300 V AC, DC, Measurement category II (between each input channel and the enclosure, between any two of input channels) Anticipated transient overvoltage: 2500 V
Measurement terminals	Insulated BNC terminal
Number of channels	4 channels
Frequency characteristics	DC to 2 MHz, -3 dB
Noise	5 mV p-p (typ.), 10 mV p-p (max.) (with the highest sensitivity range and input terminals connected with each other)
Input type	Unbalanced input (floating)
Input coupling	DC/GND
Input resistance	1 MΩ ±1%
Input capacitance	30 pF ±10 pF (at 100 kHz)
A/D resolution	16 bits (± f.s. = ±32000 data points)
Maximum sampling rate	5 MS/s
Guaranteed accuracy period	1 year
Guaranteed accuracy period after adjustment made by Hioki	1 year
Measurement accuracy	±0.1% f.s. (with the filter set at 5 Hz)

Temperature characteristics	$\pm 0.02\%$ f.s./ $^{\circ}\text{C}$
Effect of radiated radio-frequency electromagnetic field	$\pm 5\%$ f.s. (max.) at 3 V/m (with the filter set at 5 Hz)
Effect of conducted radio-frequency electromagnetic field	$\pm 5\%$ f.s. (max.) at 3 V (in the 10 V f.s. range, with the filter set at 5 Hz, with 1 V DC inputted)
Common-mode rejection ratio	80 dB or more (at 50 Hz / 60 Hz, a signal source resistance of 100 Ω)
Low-pass filter	Off, 5 $\pm 50\%$, 500 $\pm 50\%$, 5 k $\pm 50\%$, 200 k $\pm 50\%$ (Hz) -3 dB

Model U8976 High Speed Analog Unit

Conditions of guaranteed accuracy

Specified under the following conditions: installed in a Memory HiCorder and operated at 23°C ±5°C (73°F ±9°F) and 80% RH or less after a half-hour (at least) warm-up and execution of zero-adjustment.

Operating environment	Indoors, Pollution Degree 2, Operating altitude: up to 2000 m (6562 ft.)
Operating temperature and humidity	0°C to 40°C (32°F to 104°F), 80% RH or less (no condensation)
Storage temperature and humidity	-10°C to 50°C For -10°C or higher but lower than 40°C (14°F or higher but lower than 104°F), 80% RH or less (no condensation) For 40°C or higher but lower than 45°C (104°F or higher but lower than 113°F), 60% RH or less (no condensation) For 45°C to 50°C (113°F to 122°F), 50% RH or less (no condensation)
Standards	Safety: EN61010 EMC: EN61326 Class A
Dimensions	Approx. 106W × 19.8H × 196.5D mm (4.17"W × 0.78"H × 7.74"D)
Mass	Approx. 280 g (9.9 oz.)
Product warranty period	3 years
Options	Model 9665 10:1 Probe
Measurement range	100, 200, 400 mV f.s. 1, 2, 4, 10, 20, 40, 100, 200, 400 V f.s.
Maximum input voltage	400 V DC (direct input), 1000 V DC (when Model 9665 10:1 Probe is used)
Maximum rated voltage to earth	1000 V AC, DC, Measurement category II (between each input channel and the enclosure, between any two of input channels) Anticipated transient overvoltage: 6000 V
Measurement terminals	Insulated BNC terminal
Number of channels	2 channels
Frequency characteristics	DC to 30 MHz -3 dB (DC-coupled) 7 Hz to 30 MHz -3 dB (AC-coupled)
Noise	1.5 mV p-p (typ.), 2 mV p-p (max.) (with the highest sensitivity range and the terminals of each input connector connected with each other)
Input type	Unbalanced input (floating)
Input coupling	AC /DC /GND
Input resistance	1 MΩ ±1%
Input capacitance	22 pF ±5 pF (at 100 kHz)
A/D resolution	12 bits (± f.s. = ±1600 pieces of data)
Maximum sampling rate	200 MS/s
Guaranteed accuracy period	1 year
Guaranteed accuracy period after adjustment made by Hioki	1 year

Measurement accuracy	±0.5% f.s. (with the filter set at 5 Hz)
Temperature characteristics	±0.15% f.s./°C
Effect of radiated radio-frequency electromagnetic field	±5% f.s. (max.) at 3 V/m (with the filter set at 5 Hz)
Effect of conducted radio-frequency electromagnetic field	±5% f.s. (max.) at 3 V (in the 10 V range, with the filter set at 5 Hz, with 1 V DC inputted)
Common-mode rejection ratio	80 dB or more (at 50 Hz / 60 Hz, a signal source resistance of 100 Ω)
Low-pass filter	Off, 5 ±50%, 500 ±50%, 5 k ±50%, 1 M ±50% (Hz) -3 dB

Model U8977 3CH Current Unit (available for the firmware version 2.10 or later)

Conditions of guaranteed accuracy

Specified under the following conditions: installed in a Memory HiCorder and operated at 23°C ±5°C (73°F ±9°F) and 80% RH or less after a half-hour (at least) warm-up and execution of zero-adjustment.

Operating environment	Indoors, Pollution Degree 2, Operating altitude: up to 2000 m (6562 ft.)
Operating temperature and humidity	0°C to 40°C (32°F to 104°F), 80% RH or less (no condensation)
Storage temperature and humidity	-10°C to 50°C (14°F to 122°F) For -10°C or higher but lower than 40°C (14°F or higher but lower than 104°F), 80% RH or less (no condensation) For 40°C or higher but lower than 45°C (104°F or higher but lower than 113°F), 60% RH or less (no condensation) For 45°C to 50°C (113°F to 122°F), 50% RH or less (no condensation)
Standards	Safety: EN61010 EMC: EN61326 Class A
Dimensions	Approx. 106W × 19.8H × 196.5D mm (4.17"W × 0.78"H × 7.74"D)
Mass	Approx. 250 g (8.8 oz.)
Product warranty period	3 years
Options	Model CT9900 Conversion Cable (PL23 receptacle–ME15W plug) Model CT9920 Conversion Cable (PL14 receptacle–ME15W plug)
Number of input channels	3 channels
Supported current sensors	<ul style="list-style-type: none"> • Directly connectable current sensors Model 9272-05 Clamp on Sensor (20 A/200 A AC) Model CT6841-05 AC/DC Current Probe (20 A) Model CT6843-05 AC/DC Current Probe (200 A) Model CT6844-05 AC/DC Current Probe (500 A, φ20 mm) Model CT6845-05 AC/DC Current Probe (500 A, φ50 mm) Model CT6846-05 AC/DC Current Probe (1000 A) Model CT6862-05 AC/DC Current Sensor (50 A) Model CT6863-05 AC/DC Current Sensor (200 A) Model 9709-05 AC/DC Current Sensor (500 A) Model CT6904 AC/DC Current Sensor (500 A) Model CT6865-05 AC/DC Current Sensor (1000 A) Model CT6875 AC/DC Current Sensor (500 A) Model CT6876 AC/DC Current Sensor (1000 A) • Current sensors that require Model CT9920 for connection Model CT7631 AC/DC Current Sensor (100 A) Model CT7636 AC/DC Current Sensor (600 A) Model CT7642 AC/DC Current Sensor (2000 A) Model CT7731 AC/DC Auto-Zero Current Sensor (100 A) Model CT7736 AC/DC Auto-Zero Current Sensor (600 A) Model CT7742 AC/DC Auto-Zero Current Sensor (2000 A) Model CT7044 AC Flexible Current Sensor (6000 A, φ100 mm) Model CT7045 AC Flexible Current Sensor (6000 A, φ180 mm) Model CT7046 AC Flexible Current Sensor (6000 A, φ254 mm)

Measurement range	<ul style="list-style-type: none"> For the directly connectable current sensors, the instrument automatically recognizes the rating of the current sensor. 2 A, 4 A, 10 A, 20 A, 40 A, 100 A (rating: 20 A) 4 A, 10 A, 20 A, 40 A, 100 A, 200 A (rating: 50 A) 20 A, 40 A, 100 A, 200 A, 400 A, 1000 A (rating: 200 A) 40 A, 100 A, 200 A, 400 A, 1000 A, 2000 A (rating: 500 A) 100 A, 200 A, 400 A, 1000 A, 2000 A, 4000 A (rating: 1000 A) For the current sensors that require Model CT9920 for connection, choose a conversion rate or a model number. 200 A (Model CT7631, Model CT7731) 200 A, 400 A, 1000 A (Model CT7636, Model CT7736) 2000 A, 4000 A (Model CT7642, Model CT7742) 2000 A, 4000 A, 10000 A (Model CT7044, Model CT7045, Model CT7046) 2000 A, 4000 A, 10000 A, 20000 A, 40000 A, 100000 A (0.1 mV/A) 200 A, 400 A, 1000 A, 2000 A, 4000 A, 10000 A (1 mV/A) 20 A, 40 A, 100 A, 200 A, 400 A, 1000 A (10 mV/A) 2 A, 4 A, 10 A, 20 A, 40 A, 100 A (100 mV/A) 0.2 A, 0.4 A, 1 A, 2 A, 4 A, 10 A (1000 mV/A)
Frequency characteristics	DC to 2 MHz (± 3 dB)
Noise	10 mA p-p (max.) (using the 20-A sensor, with the 2 A f.s. range and input terminals connected with each other)
Low-pass filter	Off, 5 Hz, 500 Hz, 5 kHz, 200 kHz $\pm 50\%$ (-3 dB)
Input type	Current sensor
Measurement terminal	LR10-DC12BR (Hirose connector)
Input coupling	DC/GND
Input resistance	1 M Ω $\pm 1\%$
Maximum input current	Depends on a sensor.
Maximum rated voltage to earth	Non-isolated
Maximum sampling rate	5 MS/s
A/D resolution	16 bits
Guaranteed accuracy period	1 year
Guaranteed accuracy period after adjustment made by Hioki	1 year
Measurement accuracy	$\pm 0.3\%$ f.s. + (accuracy of current sensor)
Temperature characteristics	$\pm 0.045\%$ f.s./ $^{\circ}\text{C}$
Effect of radiated radio-frequency electromagnetic field	$\pm 5\%$ f.s. (max.) at 3 V/m (with the filter set at 5 Hz)
Effect of conducted radio-frequency electromagnetic field	$\pm 5\%$ f.s. (max.) at 3 V (using the 20-A sensor, with the 20 A f.s. range, with the filter set at 5 Hz, with a current of 2 A DC inputted)

Model U8978 4CH Analog Unit (available for the firmware version 2.10 or later)

Conditions of guaranteed accuracy

Specified under the following conditions: installed in a Memory HiCorder and operated at 23°C ±5°C (73°F ±9°F) and 80% RH or less after a half-hour (at least) warm-up and execution of zero-adjustment.

Operating environment	Indoors, Pollution Degree 2, Operating altitude: up to 2000 m (6562 ft.)
Operating temperature and humidity	0°C to 40°C (32°F to 104°F), 80% RH or less (no condensation)
Storage temperature and humidity	–10°C to 50°C (14°F to 122°F) For –10°C or higher but lower than 40°C (14°F or higher but lower than 104°F), 80% RH or less (no condensation) For 40°C or higher but lower than 45°C (104°F or higher but lower than 113°F), 60% RH or less (no condensation) For 45°C to 50°C (113°F to 122°F), 50% RH or less (no condensation)
Standards	Safety: EN61010 EMC: EN61326 Class A
Dimensions	Approx. 106W × 19.8H × 196.5D mm (4.17"W × 0.78"H × 7.74"D)
Mass	Approx. 250 g (8.8 oz.)
Product warranty period	3 years
Measurement range	100, 200, 400 mV f.s., 1, 2, 4, 10, 20, 40 V f.s.
Maximum input voltage	(Direct input) 40 V DC (In combination with Model 9665) 400 V DC
Maximum rated voltage to earth	(Direct input) 30 V AC, 60 V DC (between each input channel and the enclosure, between any two of input channels) (In combination with Model 9665) 300 V AC, DC, Measurement category II (between each input channel and the enclosure, between any two of input channels)
Measurement terminals	Insulated BNC terminal
Number of channels	4 channels
Frequency characteristics	DC to 2 MHz, –3 dB
Noise	5 μV p-p (typ.), 1 mV p-p (max.) (with the highest sensitivity range and the terminals of each input connector connected with each other)
Input type	Unbalanced input (floating)
Input coupling	DC/GND
Input resistance	1 MΩ ±1%
Input capacitance	30 pF ±10 pF (at 100 kHz)
A/D resolution	16 bits (± f.s. = ±32,000 data points)
Maximum sampling rate	5 MS/s
Guaranteed accuracy period	1 year
Guaranteed accuracy period after adjustment made by Hioki	1 year

Measurement accuracy	±0.3% f.s. (with the filter set at 5 Hz)
Temperature characteristics	±0.045% f.s./°C
Effect of radiated radio-frequency electromagnetic field	±5% f.s. (max.) at 3 V/m (with the filter set at 5 Hz)
Effect of conducted radio-frequency electromagnetic field	±5% f.s. (max.) at 3 V (in the 10 V range, with the filter set at 5 Hz, with 1 V DC inputted)
Common-mode rejection ratio	80 dB or more (at 50 Hz / 60 Hz, a signal source resistance of 100 Ω)
Low-pass filter	Off, 5 ±50%, 500 ±50%, 5 k ±50%, 200 k ±50% (Hz) -3 dB

Model U8979 Charge Unit (available for the firmware version 2.10 or later)

1. General specifications

Operating environment	Indoors, Pollution Degree 2, Operating altitude: up to 2000 m (6562 ft.)
Operating temperature and humidity	0°C to 40°C (32°F to 104°F), 80% RH or less (no condensation)
Storage temperature and humidity	-10°C to 50°C (14°F to 122°F) For -10°C or higher but lower than 40°C (14°F or higher but lower than 104°F), 80% RH or less (no condensation) For 40°C or higher but lower than 45°C (104°F or higher but lower than 113°F), 60% RH or less (no condensation) For 45°C to 50°C (113°F to 122°F), 50% RH or less (no condensation)
Standards	Safety: EN61010 EMC: EN61326 Class A
Dimensions	Approx. 106W × 19.8H × 196.5D mm (4.17"W × 0.78"H × 7.74"D)
Mass	Approx. 250 g (8.8 oz.)
Product warranty period	3 years
Guaranteed accuracy period	1 year

2. Specifications of input, output, and measurement

-1. Common specifications

Number of channels	2 channels
Measurement mode	Charge, pre-amplifier, voltage (selectable for each channel)
Input type	Unbalanced input (floating) In each channel, the voltage input terminal has the same-potential ground as the charge input terminal.
Common-mode rejection ratio	80 dB or more (at 50 Hz / 60 Hz, a signal source resistance of 100 Ω)
Anti-aliasing filters	Cutoff frequency (fc): 20, 40, 80, 200, 400, 800, 2 k, 4 k, 8 k, 20 k, 40 k (Hz) Switchable between on and off; the instrument automatically chooses a cutoff frequency along with the sampling rate. Attenuation property: -66 dB or higher at a cutoff frequency of 1.5 fc
Maximum sampling rate	200 kS/s
A/D resolution	16 bits (± f.s. = ±25,000 data points)
Maximum rated voltage to earth	30 V AC, 60 V DC (between each input channel and the enclosure, between any two of input channels) Anticipated transient overvoltage: 330 V

-2. Voltage input

Measurement range	10, 20, 40, 100, 200, 400 mV f.s., 1, 2, 4, 10, 20, 40 V f.s.
Maximum input voltage	40 V DC

Frequency characteristics	DC to 50 kHz -3 dB (DC-coupled) 1 Hz to 50 kHz -3 dB (AC-coupled, lower cutoff frequency: 1 Hz \pm 50%)
Noise	80 μ V p-p (typ.), 120 μ V p-p (max.), with the highest sensitivity range and the terminals of each input connector connected with each other
Input resistance	1 M Ω \pm 1%
Input capacitance	200 pF or less (at 100 kHz)
Input coupling	AC/DC/GND
Input terminals	Metallic BNC terminal

-3. Charge input

Supported detector	Charge-output acceleration detector
Measurement sensitivity	0.1 pC/(m/s ²) to 10 pC/(m/s ²)
Measurement range	40, 100, 200, 400, 1 k, 2 k, 4 k, 10 k, 20 k, 40 k, 100 k, 200 k m/s ² f.s. Measurement sensitivity: 0.1 pC/(m/s ²) to 0.25 pC/(m/s ²) 20, 40, 100, 200, 400, 1 k, 2 k, 4 k, 10 k, 20 k, 40 k, 100 k m/s ² f.s. Measurement sensitivity: 0.251 pC/(m/s ²) to 0.5 pC/(m/s ²) 10, 20, 40, 100, 200, 400, 1 k, 2 k, 4 k, 10 k, 20 k, 40 k m/s ² f.s. Measurement sensitivity: 0.501 pC/(m/s ²) to 1.0 pC/(m/s ²) 4, 10, 20, 40, 100, 200, 400, 1 k, 2 k, 4 k, 10 k, 20 k m/s ² f.s. Measurement sensitivity: 1.01 pC/(m/s ²) to 2.5 pC/(m/s ²) 2, 4, 10, 20, 40, 100, 200, 400, 1 k, 2 k, 4 k, 10 k m/s ² f.s. Measurement sensitivity: 2.51 pC/(m/s ²) to 5.0 pC/(m/s ²) 1, 2, 4, 10, 20, 40, 100, 200, 400, 1 k, 2 k, 4 k m/s ² f.s. Measurement sensitivity: 5.01 pC/(m/s ²) to 10.0 pC/(m/s ²)
Frequency characteristics	1.5 Hz to 50 kHz -3 dB
Maximum input charge	\pm 500 pC (when one of the higher six ranges is chosen) \pm 50,000 pC (when one of the lower six ranges is chosen)
Input coupling	AC/GND
Input terminals	Miniature connector (#10-32UNF)

-4. Input from acceleration sensor with the built-in pre-amplifier

Supported detector	Acceleration detector with built-in pre-amplifier
Measurement sensitivity	0.1 mV/(m/s ²) to 10 mV/(m/s ²)
Measurement range	40, 100, 200, 400, 1 k, 2 k, 4 k, 10 k, 20 k, 40 k, 100 k, 200 k m/s ² f.s. Measurement sensitivity: 0.1 mV/(m/s ²) to 0.25 mV/(m/s ²) 20, 40, 100, 200, 400, 1 k, 2 k, 4 k, 10 k, 20 k, 40 k, 100 k m/s ² f.s. Measurement sensitivity: 0.251 mV/(m/s ²) to 0.5 mV/(m/s ²) 10, 20, 40, 100, 200, 400, 1 k, 2 k, 4 k, 10 k, 20 k, 40 k m/s ² f.s. Measurement sensitivity: 0.501 mV/(m/s ²) to 1.0 mV/(m/s ²) 4, 10, 20, 40, 100, 200, 400, 1 k, 2 k, 4 k, 10 k, 20 k m/s ² f.s. Measurement sensitivity: 1.01 mV/(m/s ²) to 2.5 mV/(m/s ²) 2, 4, 10, 20, 40, 100, 200, 400, 1 k, 2 k, 4 k, 10 k m/s ² f.s. Measurement sensitivity: 2.51 mV/(m/s ²) to 5.0 mV/(m/s ²) 1, 2, 4, 10, 20, 40, 100, 200, 400, 1 k, 2 k, 4 k m/s ² f.s. Measurement sensitivity: 5.01 mV/(m/s ²) to 10.0 mV/(m/s ²)
Frequency characteristics	1 Hz to 50 kHz -3 dB

Power supply for detector	3.5 mA \pm 20%, 22 V \pm 5%
Input coupling	AC/GND
Input terminals	Metallic BNC terminal

-5. Specifications for accuracy

Conditions of guaranteed accuracy	Guaranteed accuracy period: 1 year Guaranteed accuracy period after adjustment made by Hioki: 1 year Temperature and humidity for guaranteed accuracy: 23°C \pm 5°C (73°F \pm 9°F), 80% RH or less Warm-up time: 30 minutes or more Specified after execution of zero-adjustment
Accuracy of voltage measurement	\pm 0.5% f.s. (with the filter set at 5 Hz)
Temperature characteristic of voltage measurement	\pm 0.05% f.s./°C
Accuracy of amplitude with charge inputted	\pm 2% f.s.
Temperature characteristic with charge inputted	\pm 0.2% f.s./°C
Accuracy of amplitude inputted from acceleration detector with built-in pre-amplifier	\pm 2% f.s.
Temperature characteristics of input from acceleration sensor with the built-in pre-amplifier	\pm 0.2% f.s./°C
Effect of radiated radio-frequency electromagnetic field	\pm 10% f.s. (max.) at 3 V/m (with the filter set at 5 Hz)
Effect of conducted radio-frequency electromagnetic field	\pm 10% f.s. (max.) at 3 V (with the filter set at 5 Hz)

3. Specifications of functions

Low-pass filter	Off, 5 \pm 50% (voltage input only), 500 \pm 50%, 5k \pm 50% (Hz) -3 dB
TEDS	IEEE1451.1.4 Class 1 compliant The instrument reads out sensor information to automatically configure the sensitivity setting.

 **WARNING**

Touching any of the high-voltage points inside the instrument is very dangerous. Do not attempt to modify, disassemble, or repair the instrument. Doing so may cause a fire, electric shock, or injury.

Calibration

The calibration period varies depending on the state of the instrument and installation environment. We recommend that the calibration period be determined in accordance with the state of the instrument and installation environment. Please contact your authorized Hioki distributor or reseller to have your instrument periodically calibrated.

Backing up the data

The instrument may be initialized (returned to the factory default settings) when it is repaired or calibrated.

Before you ask for repair or calibration, it is recommended to back up (save or record) the measurement conditions and waveform data.

Refer to “4 Saving/Loading Data and Managing Files” of Instruction Manual.

Precautions During Shipment

Be sure to observe the following precautions:

- To avoid damage to the instrument, remove any accessories and optional equipment from the instrument. Use the original packing materials the instrument was shipped in. Damage that occurs during transportation is not covered by the warranty.
- When sending the instrument for repair, be sure to include a memo that describes the problem in detail.

Replaceable parts and operating lifetimes

The characteristics of some of the parts used in the instrument may deteriorate with extended use. To ensure the instrument can be used over the long term, it is recommended to replace these parts on a periodic basis. When replacing batteries, please contact your authorized Hioki distributor or reseller.

The service life of parts varies with the operating environment and frequency of use. Parts are not guaranteed to operate throughout the recommended replacement cycle.

Part Name	Recommended replacement cycle	Remarks/conditions
Fan motor	Approx. 5 years	
LCD (backlight) (Half-life of brightness)	Approx. 80,000 hours	At an ambient temperature of 25°C The service life varies significantly depending on the ambient environment. In particular, the service life reduces in an environment containing sulfur and halogen, and high temperature environment.
Model U8332 SSD Unit	Approx. 1,400 hours	At an ambient temperature of 25°C Total bytes written (TBW): Approx. 300 TB Data retention period: About one year (When the instrument is turned off) Data backup at regular intervals is recommended.
Model U8333 HD Unit	Approx. 20,000 hours	–
Electrolytic capacitors	Approx. 10 years	Deteriorates in approx. 10 years when the instrument is used in a severe environment (at an ambient temperature of 40°C).
Lithium battery	Approx. 10 years	The instrument contains built-in backup lithium batteries, which offer a service life of about 10 years. If the date and time deviate substantially at power-on, it is the time to replace that battery. Contact your authorized Hioki distributor or reseller.

The fuse is housed in the power unit of the instrument. If the instrument is not powered on, the fuse may be blown. Customers cannot replace the fuse or repair the instrument. Please contact your authorized Hioki distributor or reseller.

6.1 Troubleshooting

If damage is suspected, read the “Before having the instrument repaired” section before contacting your authorized Hioki distributor or reseller.

Before sending the instrument for repair

If the power or operating keys does not operate properly

Problem	Check item or cause	Remedy	Reference
Nothing appears on the screen even if you press the power key.	<ul style="list-style-type: none"> Is the power cord connected? Is the power cord connected correctly? 	Check that the power cord is connected properly.	p. 63
The instrument does not operate even if you press the keys.	Is any key being held down?	Check if the keys are stuck.	–
	Is the key lock engaged?	Disengage the key lock.	p. 33

If the display or behavior shows an abnormality

Condition	Check item or cause	Remedy	Reference
Blank screen	Is the display in auto-power off mode?	Press any key and check if the screen appears.	*
The screen does not display any waveforms even if you press the START key.	<ul style="list-style-type: none"> Is the message “Waiting for Pre-Trigger” displayed? Is the message “Waiting for Trigger” displayed? 	When the pre-trigger is engaged, the instrument is not triggered while it is writing data in the pre-trigger memory. Recording starts when the instrument is triggered.	p. 75
The displayed waveforms do not change.	Are current sensors or connection cords connected correctly?	Check the current sensors and connection cords for disconnection.	p. 40
	<ul style="list-style-type: none"> Is the measurement range suitable for the measurement target? Is the low-pass filter setting configured to be used? 	Check the settings of the input channels.	p. 73
During a measurement, the instrument displays waveforms with much lower frequencies than the actual.	Aliasing may be exhibited.	Use a faster sampling rate.	p. 71
		Use [Auto range] to automatically set the measurement range.	p. 81

*: “11 Configuring the System Environment Settings” of Instruction Manual

If the instrument cannot save any data

Condition	Check item or cause	Remedy	Reference
The instrument cannot save any data on a storage device including an SD card.	• Do you use Hioki's optional SD card?	Use Hioki's optional SD card.	p. 5
	• Does the storage device have sufficient free space? • Has the number of files in the folder reached 5,000?	Initialize or replace the storage device.	p. 59
		Up to 5000 files can be saved in a folder. If you would like to create more files, adjust the quantity.	*
	• Is the storage device properly inserted?	Properly insert the storage device.	p. 59
	• Have you formatted the storage device?	Format the storage device before initial use.	p. 61

*: "4.4 Managing Files" of Instruction Manual

If the cause cannot be revealed

Initialize the instrument. All settings are restored to the factory default.
Refer to "6.2 Initializing the Instrument" (p. 139).



6.2 Initializing the Instrument

Choose settings configured on the instrument and restore them to the factory default.

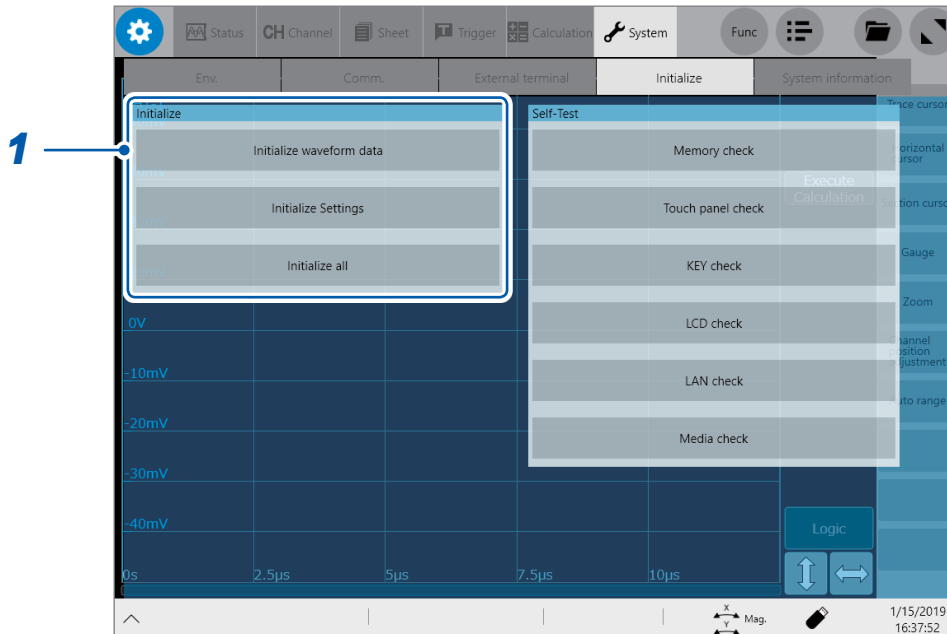
 > [System] > [Initialize]



1 Choose an item to be restored.

Initialize waveform data	Discards the waveform data saved in the internal memory.
Initialize Settings	Restores the settings for measurement, channels, sheets, triggers, and calculation tabs.
Initialize all	Restores all the settings to the factory default. However, the following settings are not restored: <ul style="list-style-type: none"> • Display setting ( > [System] > [Env.] > [Customize display]) • Clock setting ( > [System] > [Env.] > [Date and time]) • Computer setting ( > [System] > [Comm.] > [Open PC settings.]

2 Tap [OK].

6.3 Message

If any problem is found, the screen will display an error message or a warning message. It also display an information message with advice for usage.

Action that should be taken after a message

If a message remains

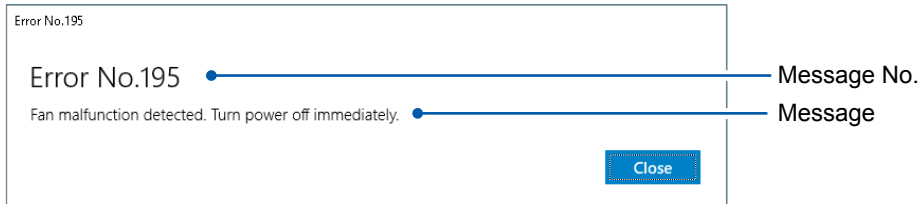

If an error or warning message remains, check the details and tap **[Close]**.

If a message disappears in several seconds

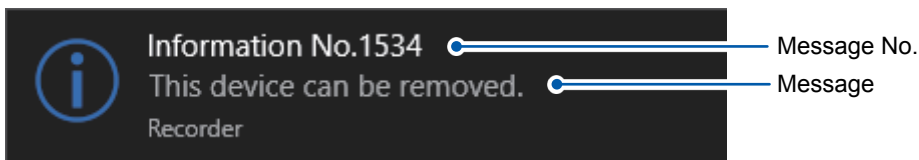

Some of the warning and information messages disappear in a few seconds. Check the details while the screen is displaying the message.

To inform of a message with a beep

Select  > **[System]** > **[Env.]**, and set **[Beep sound]** to **[Alert]** or **[Alert+Action]**.

Refer to "11 Configuring the System Environment Settings" of Instruction Manual.

Error messages

The list of error messages is as follows. Check the solution.

If an error is displayed on the screen at power-on, the instrument is necessary to be repaired.

Contact your authorized Hioki distributor or reseller.

No.	Message	Solution	Reference
176	Internal temperature is abnormal. Please turn the power off.	Check the operating temperature environment and the fan rotation, and then send the instrument for repair.	—
195	Fan malfunction detected. Power off immediately.	High internal temperature may damage the instrument. Immediately turn off the instrument and send the instrument for repair.	—
196	Change the input unit setup so that the total number of channels of Model 8971 does not exceed 8.	Up to four pieces of Model 8971 Current Unit can be installed in the instrument. Turn off the instrument and change the module configuration.	"2.1 Installing and Removing Modules" (p. 38)
639	Hardware error	A hardware error is detected. Immediately turn off the instrument and send the instrument for repair.	—
643	Hardware error		
644	Hardware error		
645	Hardware error	A hardware error is detected. Immediately turn off the instrument and send the instrument with the modules for repair. *: The character "X" indicates the module numbers that has failed (1 through 8).	—
646	Hardware error		
647	Hardware error		
648	Hardware error		
649	Unit X*: ROM checksum error		
651	System power supply error. Power off immediately.	A system power supply malfunction detected. Immediately turn off the instrument and send the instrument for repair.	—
652	Hardware error	A hardware error is detected. Immediately turn off the instrument and send the instrument for repair.	—
653	Processing could not be successfully completed.	An error occurred during an internal process of the instrument. Tap [Shutdown] to turn off the instrument and cycle the instrument. You can continue the measurement by tapping [Continue] ; however, you should turn off the instrument once.	—

Warning messages

The list of warning messages is as follows. Check the solution.

No.	Message	Solution	Reference
10	Please insert media.	Insert an SD card or a USB flash drive.	"2.7 Preparing Storage Devices (Recording Media)" (p. 59)
13	Disk full.	The instrument cannot save any files because of insufficient free space on the storage device. Delete unnecessary files to free up enough space or use a new storage device.	"2.7 Preparing Storage Devices (Recording Media)" (p. 59) "4.4 Managing Files" of Instruction Manual
14	Cannot load this file.	The chosen file cannot be loaded.	"4.3 Loading Data" of Instruction Manual
15	Unable to access file.	Check that the storage device is properly inserted.	"2.7 Preparing Storage Devices (Recording Media)" (p. 59)
22	No waveform data to save.	Perform another measurement or load a file.	"4.3 Loading Data" of Instruction Manual
25	This device cannot be removed.	The instrument is accessing the device. After the SAVE key is turned off remove the device.	"1.2 Name and Function of Each Part" (p. 20)
30	Auto-ranging failed.	Check the input signals.	"3.7 Measuring Signals With the Auto-range Setting" (p. 81)
31	Invalid section cursor position.	Section cursors are placed at improper positions (outside the waveform range). Check the section cursor positions.	"2.4 Scrolling Through Waveforms" of Instruction Manual
44	No event mark.	Put an event mark.	"13.1 External Input and Output" of Instruction Manual
45	Out of range.	–	–
60	No waveform data.	Acquire waveform data.	–
70	Voltage Sag triggering is disabled (valid time base range: 2 kS/s to 100 MS/s).	You can use the voltage sag trigger setting only when the sampling rate is set to one from 2 kS/s to 100 MS/s.	"5.6 Triggering the Instrument Using Analog Signals" of Instruction Manual
74	Auto balance failed.	Check if the strain gauge transducer is not loaded, or if it is connected correctly.	"Strain gauge transducer" (p. 44)
78	Recording length is too long.	For waveform calculation, the recording length have to be 2,000,000 points or less. Shorten the recording length.	"3.2 Setting Measurement Conditions" (p. 70)
83	No channel selected for use.	Set the [Use] buttons on one or more of the channels to [On] .	"Analog channels" in Section 1.3 of Instruction Manual
85	Invalid search condition.	Check the search condition settings.	"6 Search Function" of Instruction Manual
112	Aborted.	–	–

No.	Message	Solution	Reference
113	Save processing was interrupted.	Real-time save has been canceled due to slow writing speed to the storage device. Check solutions below before measurement. <ul style="list-style-type: none"> • Choose a slower sampling speed. • Reduce the number of saving channels. • Replace with a storage device that has a faster writing speed. 	"4.2 Saving Data" of Instruction Manual
123	No data matching the search criteria has not been found.	Check the search criteria setting.	"6 Search Function" of Instruction Manual
124	No waveform, or recording length is not long enough.	Acquire waveform data. Otherwise, specify a correct recording length.	"3.2 Setting Measurement Conditions" (p. 70) "1.2 Setting Measurement Conditions" of Instruction Manual
208	Server communication error.	Communication may be unstable, or the instrument may not support the email or FTP servers running on the server. The connection may be established by enabling PASV for the FTP or changing the server security setting.	"12 Connecting the Instrument to Computers" of Instruction Manual
209	LAN disconnected.	Check the network environment.	"12 Connecting the Instrument to Computers" of Instruction Manual
210	LAN timed out.	Check the network environment.	"12 Connecting the Instrument to Computers" of Instruction Manual
211	LAN authentication required.	Email or FTP server authentication is required. Enable the authentication.	"12 Connecting the Instrument to Computers" of Instruction Manual
212	LAN authentication failed.	Login to email or FTP server failed. The user name or password may be incorrect.	"12 Connecting the Instrument to Computers" of Instruction Manual
213	Authentication setup invalid.	The user name or password for email authentication has not been set.	"12 Connecting the Instrument to Computers" of Instruction Manual
214	Encryption password not set.	Encryption is enabled, but a password has not been set.	"12 Connecting the Instrument to Computers" of Instruction Manual
215	Invalid server address.	Check the address setting.	"12 Connecting the Instrument to Computers" of Instruction Manual
216	POP3 Server not found.	Check the POP3 server address.	"12 Connecting the Instrument to Computers" of Instruction Manual
217	Cannot connect to POP3 Server.	Check the POP3 server address. POP3 may not be running on the specified server.	"12 Connecting the Instrument to Computers" of Instruction Manual
218	E-mail 'to' or 'from' settings invalid.	Check the recipient's and sender's addresses of the email setting.	"12 Connecting the Instrument to Computers" of Instruction Manual

No.	Message	Solution	Reference
219	E-mail recipient error.	The server refused to send the email to the recipient. Check the recipient's address.	"12 Connecting the Instrument to Computers" of Instruction Manual
221	The sent e-mail size exceeds the limit.	The email size exceeds limits. Reduce the recording length or increase the size setting.	"12 Connecting the Instrument to Computers" of Instruction Manual
222	E-mail size exceeds server limits.	The sent email size exceeds the email server limit. Reduce the recording length or change the attachment contents.	"12 Connecting the Instrument to Computers" of Instruction Manual
223	FTP transfer failed.	Check the network environment. The FTP server may have rejected the file. Check the FTP server setting. For example, creating a directory (DIR) or file is prohibited, or the server is full.	"12 Connecting the Instrument to Computers" of Instruction Manual
224	E-mail transfer failed.	Check the network environment. The email server may have rejected the email message. Check the transmission condition of the email server. For example, the size or the number of mails reaches the limit of the server.	"12 Connecting the Instrument to Computers" of Instruction Manual
225	Data send aborted.	The transmission is aborted. Incomplete data may have been transmitted via FTP or email. Check the transmitted data.	"12 Connecting the Instrument to Computers" of Instruction Manual
226	Network error.	A network error occurred during communication. Check the network environment.	"12 Connecting the Instrument to Computers" of Instruction Manual
232	File processing could not be successfully completed.	An unexpected error occurred while a file is being processed in the SD card or USB flash drive. Replace the storage device with another or cycle the instrument.	"2.7 Preparing Storage Devices (Recording Media)" (p. 59)
241	File processing error.		
601	Zero-adjustment required.	Execute zero-adjustment.	"2.11 Executing Zero-Adjustment" (p. 65)
606	Current sensor recognized.	—	—
607	Current sensor removed.	Check the connection of the current sensors.	—
616	Search target channel has no data.	Perform another measurement or load a file.	"4.3 Loading Data" of Instruction Manual
626	Numerical calculation function has been turned off.	Numerical calculation is not available when the envelope is in use.	"7 Numerical Calculation Function" of Instruction Manual

No.	Message	Solution	Reference
630	Remaining clamp current that can be supplied from Z5021 Current Clamp's power supply terminal is A [A].	The instrument can supply up to 4.8 A of current for current sensors. When current sensors connects to Model 8971 Current Unit, the instrument recognizes them automatically and displays the available current capacity calculated based on the total capacity. Choose a current sensor based on the displayed current capacity.	"2.3 Supplying Power to Current Sensors" (p. 53)
631	Total clamp current that can be supplied from Z5021 Current Clamp's power supply terminal is 4.8 [A].		
634	Digital filter calculation function has been turned off.	The real-time waveform and digital filter calculations cannot simultaneously be used.	-
635	Real-time waveform calculation function has been turned off.		
640	Number of search results exceeded 1000. Search has been canceled.	The instrument can display up to 1000 search results.	"6 Search Function" of Instruction Manual
641	Insufficient data to perform search.	Check the scope of search.	"6 Search Function" of Instruction Manual
642	Unable to capture a stable fundamental wave.	Check the setting for the fundamental wave.	"6 Search Function" of Instruction Manual
650	Cannot set numerical value. Check the setting of upper and lower limits.	-	-

6.4 Self-check

Executing the self-check function checks the instrument for malfunctions. The self-check consists of the following checks:

 > [System] > [Initialize]

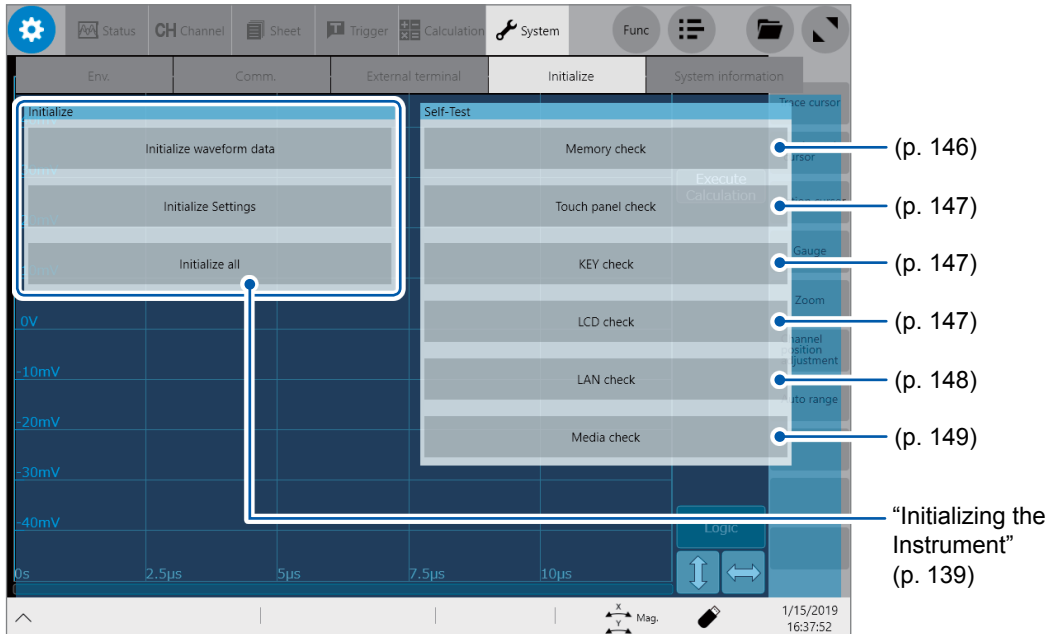

Memory check

This function checks the storage memory, backup memory (SRAM memory), and calculation memory (DSP memory).

IMPORTANT

- Save waveform data in a storage device before performing the memory check. Any waveform data will be deleted after the memory check.
- Do not turn off the instrument during the memory check.

1 Tap [Memory check].

2 Tap [Execute].
The memory check starts.

To cancel the check:

Pressing the **STOP** key interrupts the item being checked.
Pressing the operation keys other than the **STOP** key is ignored.
The results are displayed once the memory check has been complete.

PASS	The instrument has passed the check.
FAIL	The instrument has failed the check. Send it for repair.
Cancel	One of the items was interrupted.

Touch panel check

This check tests the touch panel for proper operation.

- 1 Tap [Touch panel check].**
The sides to be checked go white.
- 2 Place your finger on a mark on the edge of a side and trace the side to the other mark on the side.**
When the mark changes [✓], release your finger.
The screen displays the test conclusion after all of the marks have changed to [✓].

PASS	The touch panel had passed the check.
FAIL	The touch panel has failed the check. Send instrument for repair.

Key check

This check tests the keys and rotary knobs for proper operation.

- 1 Tap [KEY check].**
- 2 Press each operation key once or several times.**
The corresponding key is highlighted.
- 3 Turn the rotary knob clockwise and counterclockwise one or more times each.**
Operating all of the keys completes the check.

To cancel the check:

Tapping [Close] redisplay the previous screen.

LCD check

This check tests the display for proper operation.

- 1 Tap [LCD check].**
The screen becomes uniformly red.
- 2 Tap the screen or press any key to check the display state.**
Every operation changes the screen in the following order, eventually redisplay the the original screen.
Red, green, blue, black, and white.

LAN check

This check tests the LAN cable for malfunction such as disconnection.

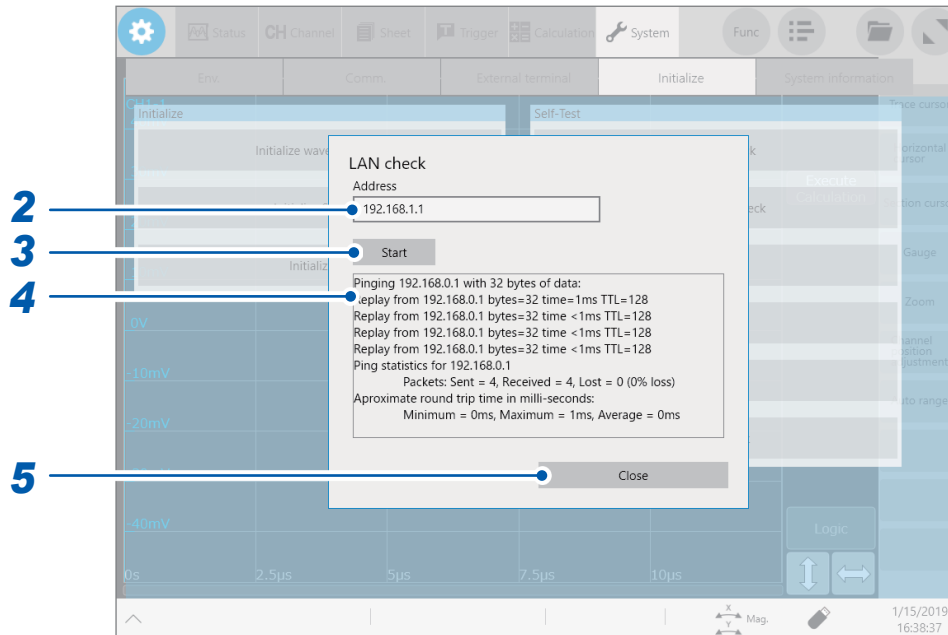

- 1 Tap [LAN check].
- 2 Enter an IP address used for connecting to LAN in the [Address] box.
- 3 Tap [Start].
- 4 Check the transmission/reception result on the screen.
- 5 Tap [Close].

Media check

This check tests the storage devices for malfunction.

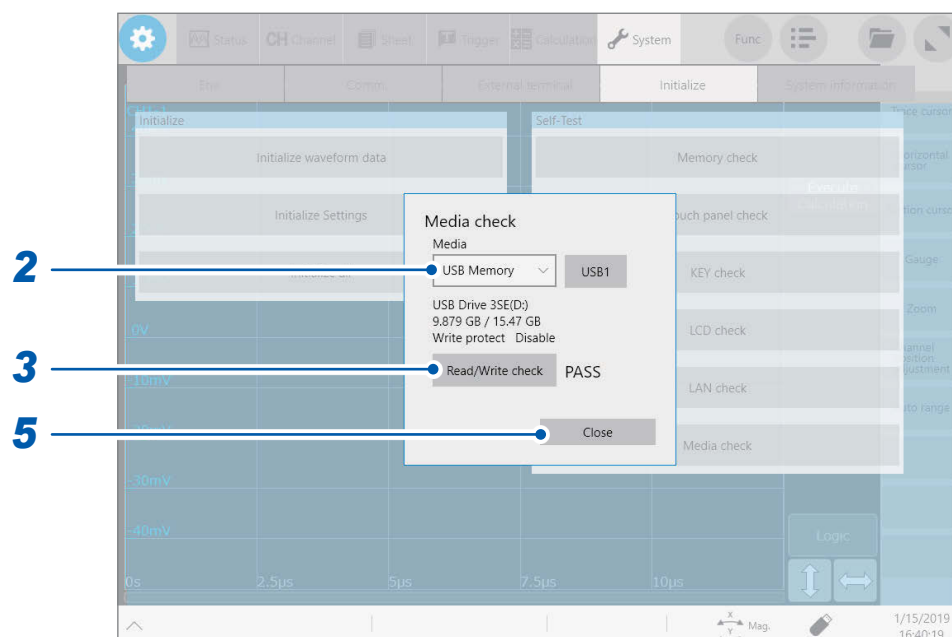

- 1** Tap **[Media check]**.
- 2** Tap the **[Media]** box and choose a storage device from the list.
The screen displays the information of the chosen storage device.
- 3** Tap **[Read/Write check]**.
The read/write check starts.
- 4** Check the transmission/reception result on the screen.
- 5** Tap **[Close]**.

System configuration check

You can check the functions and devices installed in the instrument in a list.

 > [System] > [System information]

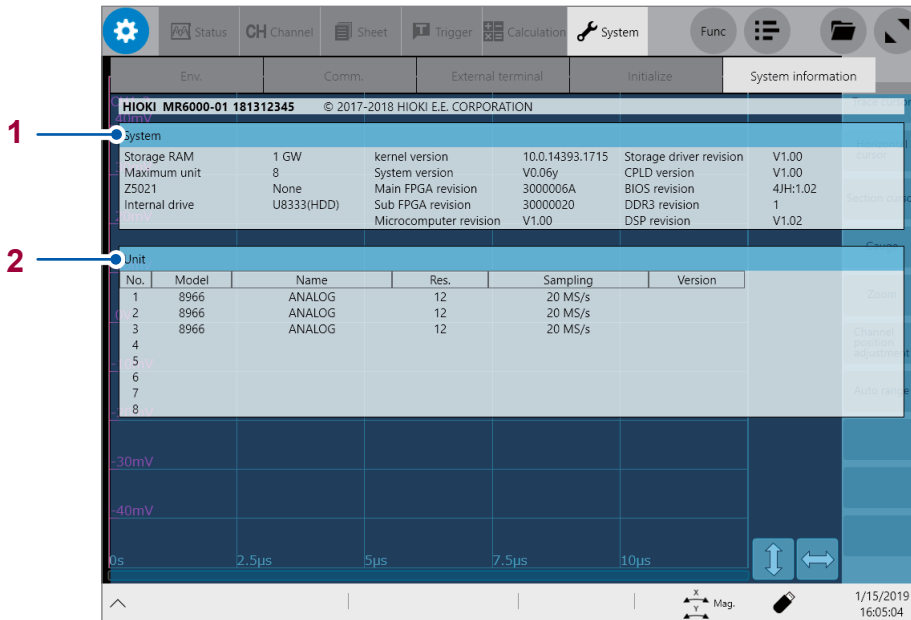

No.	Item	Description
1	System configuration	You can check the system configuration, software version, and board version of the instrument.
2	Module configuration	You can check the model number, name, resolution, sampling rate, and firmware version number of each module (unit) installed in the instrument.

6.5 Cleaning the Instrument

- To clean the instrument and modules, wipe it gently with a soft cloth moistened with water or mild detergent. Wipe the LCD gently with a soft, dry cloth. Do not use organic solvent.

CAUTION



Clean the vents periodically to avoid blockage. When the vents get clogged, the instrument's internal cooling effect is hampered, and this can lead to damage to the instrument.

6.6 Disposing of the Instrument (Removing the lithium battery)

When disposing of this instrument, remove the lithium battery and dispose of the battery and instrument in accordance with local regulations. The instrument contains the lithium battery for memory backup.

WARNING



To avoid an electric shock, turn off the instrument and disconnect any connection cords from the instrument before removing the lithium battery.



Do not short-circuit, recharge, disassemble or dispose of them in fire. The battery may explode if mistreated.



Keep batteries away from children to prevent accidental swallowing.

CALIFORNIA, USA ONLY
Perchlorate Material - special handling may apply.
See www.dtsc.ca.gov/hazardouswaste/perchlorate

Removing the lithium battery

Required tools:

Flat-head screwdriver (No.2), Torx screwdriver (T10), hex wrench (2.5), and nippers (one each)

- 1 Turn off the instrument and remove any cords.**
- 2 Remove rear and left panels.**
Pushing the left panel downward enables easy removal from the body.
- 3 Remove right panel.**
Pushing the right panel downward enables easy removal from the body.
- 4 Remove the handle.**
- 5 Remove the cover of the media box.**
- 6 Remove the upper panel.**
- 7 Use nippers to remove the lithium battery from the board.**
Pull the lithium battery up from the circuit board, and cut the positive and negative leads with the nippers.

Disposing of the Instrument (Removing the lithium battery)

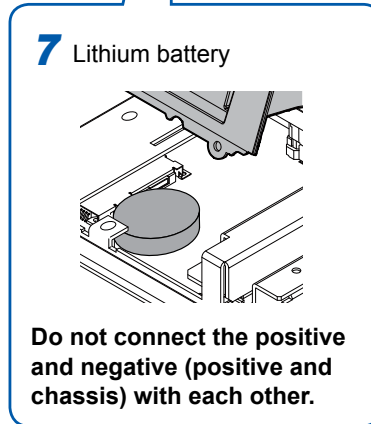
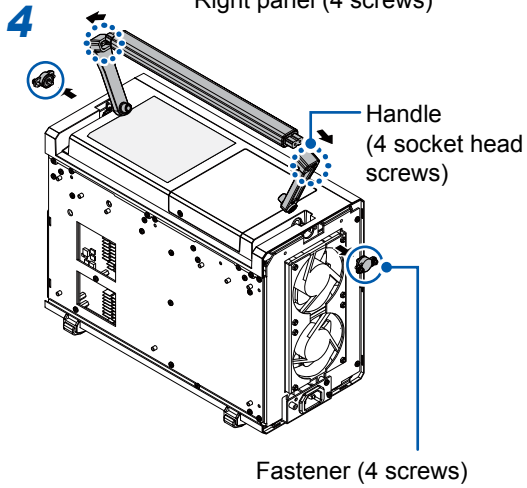
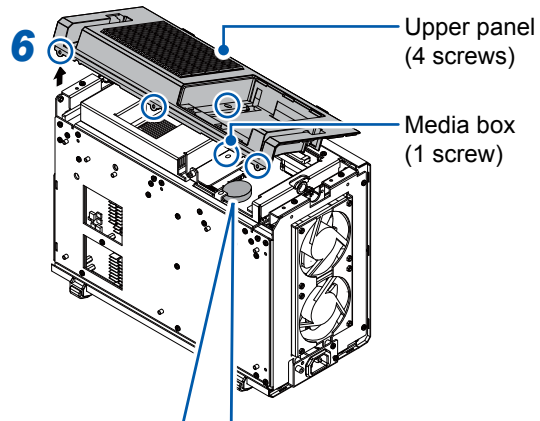
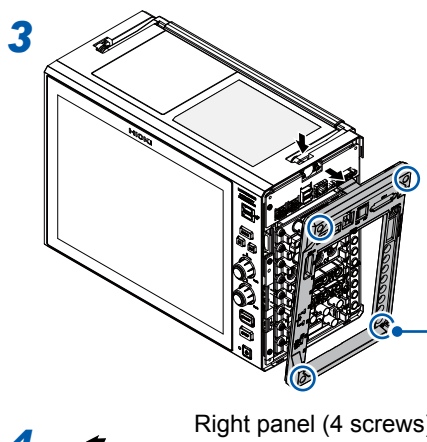
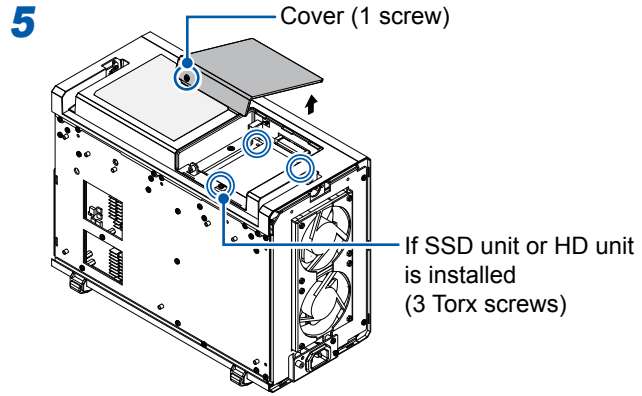
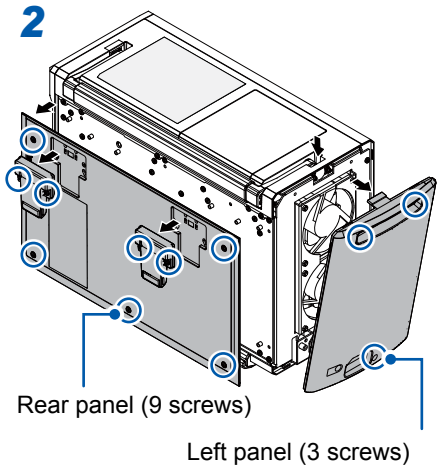

Tools used

- : Phillips-head screwdriver (No.2)
- ⊙ : Torx screwdriver (T10)
- ⊛ : Hex wrench (2.5)

Index

A

Acceleration sensor	49
Aliasing	71
Analog channel	72
Auto-range	81
Auto-save	78

B

Beep	140
Blank panel	12
BMP	80
Built-in drive	60

C

Calibration	67
Carrying case	5
Channel number	39
Clock	64
Comment	34, 73
Computer	57, 87
Connection cord	11, 40, 41
Current sensor	46, 53

D

Date and time	64
Displayed-block number	Instruction Manual
Display setting	Instruction Manual
Disposal	
Lithium battery	151

E

Email transmission	Instruction Manual
Error	141
External control terminal	55
External sampling	54
External trigger	56
EXT.SMPL	16, 54
EXT.TRIG	16, 56

F

File management	Instruction Manual
File screen	Instruction Manual
File size	Instruction Manual
Format	61
FTP transfer	Instruction Manual
Functional earth terminal	63

H

Help function	33
---------------------	----

I

IN1	16, 56
IN2	16, 56
Initializing the instrument	139
Input channel	72

K

Key check	147
Key lock	33

L

LAN	57
LCD check	147
Level trigger	75
Lithium battery	151
Logic probe	15, 51
Low-pass filter	74
L.P.F	74

M

Magnification/demagnification ratio	28
Maximum input voltage	10
Maximum rated voltage to earth	10
Measurement range	73
Measurement target	40
Media box	
How to open	62
Memory check	146
Model 9665 10:1 Probe	42
Model 9666 100:1 Probe	42
Model U8332 SSD Unit	60, 105
Model U8333 HD Unit	60, 106
Model U8969 Strain Unit	44, 112
Model Z5021 Probe Power Unit	53, 105
Module	5, 38
Ratings of modules	10
Module-specific setting	Instruction Manual
Mouse	34

N

Number of points	70
Numerical calculation	Instruction Manual

O

Option.....	5
OUT1.....	16, 56
OUT2.....	16, 56

P

Power key.....	63
Probe compensation signal output.....	42
Probe ratio.....	74

Q

Quick-access menu.....	32
Quick save.....	78

R

Recooding length.....	70
Replaceable parts and operating lifetimes.....	136

S

Sampling rate.....	28, 70
SAVE key.....	78, 79
Save type.....	78, 80
Saving data	
Auto-save.....	78
Quick save.....	78
Screenshot.....	79
Selective save.....	78
Scaling.....	Instruction Manual
Scrolling through waveforms.....	86
SD memory card.....	59
Search.....	Instruction Manual
Selective save.....	78
Self-check.....	146
Sheet selection.....	Instruction Manual
Sheet setting.....	Instruction Manual
Shortcut key.....	Instruction Manual
Shot.....	70
SMB cable.....	54
START key.....	77
STOP key.....	77
Storage device.....	59
System protection.....	Instruction Manual

T

Thermocouple.....	43
Touch keyboard.....	34
Rotary knob.....	28
Touch panel.....	27
Trace cursor.....	83
Trigger.....	75

TRIG.OUT.....	16, 56
---------------	--------

U

USB flash drive.....	59
----------------------	----

W

Warm-up.....	63
Warning.....	142
Waveform viewer.....	87

Z

Zero-adjustment.....	65
Zoom in.....	86
Zoom out.....	86

