

Keysight Technologies B2900 Series Precision Source/Measure Unit

Configuration
Guide



NOTICE: This document contains references to Agilent Technologies. Agilent's former Test and Measurement business has become Keysight Technologies. For more information, go to www.keysight.com.



Contents

1. B2900A Product Configuration	
Product Line up of the B2900A Series	1-2
Options of B2900A Series	1-3
Furnished Accessories	1-4
2. B2900A Accessories	
Cables	2-2
Adapters & Connectors	2-5
Test Fixture	2-8
N1295A Device/component Test Fixture	2-8
U2941A Test Fixture	2-9
16442B Test Fixture	2-10
Other I/F and Interlock	2-11
Rear Panel	2-11
Program and Interface Capabilities	2-13
Programming Language	2-13
Program Memory	2-13
LXI	2-13
USB File System	2-13
Digital I/O Interface	2-13
Installing the Interlock Circuit	2-14
Rack Installation	2-15
3. Connection	
Connecting to a DUT	3-2
“2-wire connections” or “4-wire connections”	3-2
Floating	3-3
To use Test Leads	3-3
Connection with Test Fixture	3-4
To use N1295A Test Fixture	3-4
To use U2941A Test Fixture	3-6
To use 16442B Test Fixture	3-8
Connection with Prober	3-12
Connecting to Manual Prober	3-12
2-wire (Non-Kelvin) connection	3-12
4-wire (Kelvin) connection for High Force and High Sense	3-13
4-wire (Kelvin) connection for Low Force and Low Sense	3-13
Kelvin to non-Kelvin connection	3-14

Contents

To make connection to reduce leakage current	3-15
Guarding	3-15
To make connection to measure low resistance	3-16
Kelvin Connection	3-16
4. Ordering Examples	
Agilent B2900A for Resistance measurement	4-2
Agilent B2900A for LED IV Measurement	4-3
Agilent B2900A for LIV Test of Laser Diode	4-4
Agilent B2900A for Diode/LED/OLED/Varistor Test	4-5
Agilent B2900A for Characterization of FET & Bipolar Transistor	4-6
Agilent B2900A for DC Bias to Network Analyzer	4-8

1.1 Product Line up of the B2900A Series

The Agilent B2900A Series of Precision Source/Measure Unit provides wider voltage and current coverage, higher resolution, and graphical user interface for more quicker test, debug and characterization on the bench top.

The B2900A series consists of four models, the B2901A, B2902A, B2911A and B2912A, differentiated through their measurement specifications and by the number of SMU channels (one or two) they support. This makes it easy to select the exact price/performance point to meet your testing needs.

Table 1-1 B2900A Series Ordering Information

Item	Description
B2901A	Precision Source/Measure Unit, 1ch, 100 fA, 210 V, 3 A DC/10.5 A pulse
B2902A	Precision Source/Measure Unit, 2ch, 100 fA, 210 V, 3 A DC/10.5 A pulse
B2911A	Precision Source/Measure Unit, 1ch, 10 fA, 210 V, 3 A DC/10.5 A pulse
B2912A	Precision Source/Measure Unit, 2ch, 10 fA, 210 V, 3 A DC/10.5 A pulse

Table 1-2 B2900A Series measurement capabilities

Model	Number of SMU channels	Effective set and measure value			
		Minimum resolution		Maximum current	Maximum voltage
		Set	Measure		
B2901A	1	1 pA, 1 μ V	0.1 pA, 0.1 μ V	\pm 3.03 A DC, \pm 10.5 A Pulse	\pm 210 V
B2902A	2				
B2911A	1	0.01 pA, 0.1 μ V			
B2912A	2				

NOTE

Max number of steps per second and Maximum sample rate are also different between B2901A/B2902A and B2911A/B2912A. For details, refer to the data sheet of the B2900A series.

Figure 1-1 Agilent B2912A Precision Source/Measure Unit 10 fA, 2ch



1.2 Options of B2900A Series

This section describes Option items of the Agilent B2900A Series Precision Source/Measure Unit.

Table 1-3 B2900A Options

Option	Description	OP Instruction
Specify the language of the paper manual if you need		
ABA	Paper Manual (User's Guide), English	<ul style="list-style-type: none"> Additional printed paper manual. (English) The B2900A series product includes CD-ROM manuals.
ABJ	Paper Manual (User's Guide), Japanese	<ul style="list-style-type: none"> Additional printed paper manual. (Japanese) The B2900A series product includes CD-ROM manuals.
AB0	Paper Manual (User's Guide), Traditional Chinese	<ul style="list-style-type: none"> Additional printed paper manual. (Traditional Chinese) The B2900A series product includes CD-ROM manuals.
AB2	Paper Manual (User's Guide), Simplified Chinese	<ul style="list-style-type: none"> Additional printed paper manual. (Simplified Chinese) The B2900A series product includes CD-ROM manuals.
Select calibration options (optional)		
AJ6	ANSI Z540 compliant calibration	<ul style="list-style-type: none"> ANSI Z540 compliant calibration
UK6	Commercial cal. certificate w/ test data	<ul style="list-style-type: none"> Test Data for ISO 9001/2 Commercial Calibration. This option provides measurement test data for the standard commercial calibration and test equipment trace information.
Select rack mount kit (optional)		
1CM	Rack mount kit	<ul style="list-style-type: none"> Rack mount kit for the B2900A series. 2U height EIA and 1/2 rack width

1.3 Furnished Accessories

The B2900A is furnished with the accessories listed in the following table.

Table 1-4 **B2900A Options**

Description	Qty.	Note
Product Reference CD	1	Stores electronic files of user manuals, drivers and software
Agilent I/O Libraries CD	1	Stores driver and installation software for the Agilent I/O library
Quick Reference	1	Printed reference for quick start (English)
Certificate of Calibration (without test data)	1	Certificate of Calibration without test data. If you need the test data, please specify option UK6.
USB cable	1	USB cable (1.8 m)

The Product Reference CD stores the following software and drivers.

- **Agilent B2900A Quick I/V Measurement Software** - This PC-based software makes it easy to quickly set up and perform IV measurement and to display the measurement data in a table or graph without any programming. The software allows you to control up to two members of the B2900A series over a GPIB or LAN connection, or one member via a USB connection using furnished USB cable.

Operating System: Windows 7 (64bit/32bit), XP SP3 (32bit)

Other requirements: Microsoft .NET framework 4.0 or later and Agilent IO Libraries 16.0 or later.

- **Agilent B2900A Graphical Web Interface** - is a web browser based instrument control panel. It enables you to set up and perform a measurement easily and quickly from a web browser using the B2900's built-in web server. This allows you to control one B2900A series unit over a LAN connection.
- **IVI-C or IVI-COM drivers** - supports Agilent VEE, Microsoft Visual Studio (Visual Basic, Visual C++, Visual C#), National Instrument LabWindows and LabVIEW. It is compatible with Windows 7 (64bit/32bit), XP SP2 (32bit) IO Libraries 16.0 or later.
- **LabVIEW driver (VI)** - National Instruments LabVIEW 7.0 or later. LabVIEW drivers are available at NI.COM.

2.1 Cables

The B2900A series has banana type output ports with Force, Sense and Guard potential. However, if you use conversion adapter, you can use BNC type cables or Triaxial cables so that each SMU channels can connect to dedicated test environment for DUT such as test fixture or wafer prober. The great variety of available cables can be categorized into mainly five types:

- **Banana Test Lead** - To simplify the connections, you can use 2-wire connections or 4-wire connections by using banana test leads for connection of DUT. There are many types of DUT interface.
- **BNC cables** - Co-axial type cables. Central signal line is surrounded by shield potential. However, this is not suitable for ultra low current measurement below nA level. For these low current measurements, we recommend to use the following Triaxial cables.
- **Triaxial cables** - have three leads - a central conductor for the signal, an encapsulating conductor that shields the center signal by employing the same voltage thus decreasing a possible leakage current - and an outer conductor that serves as Common. To use this cable, Banana to Triaxial adapter is required.

Table 2-1 Banana Test Leads for the Agilent B2900A series





Model/Option	Description	Additional Information
U8201A	<p>Combo Test Lead Kit</p> <p>Couple of test leads, test probes, alligator clips, SMT grabbers, fine-tips test probes, and banana plugs, CAT III 1000 V, 15 A maximum</p> <p>Two kits are required for the 4-wire connections.</p>	
11059A	<p>Kelvin Probe Set</p> <p>This kelvin probe set consists of two gold-plated flat tweezers with special gripping surfaces. This design assures a very precise contact to the component and very precise measurements. The ground guard connector removes ground-related errors.</p> <ul style="list-style-type: none"> • Maximum voltage : 42 V • Termination : 5 signal banana plugs (4-wire measurement plus ground) • Cable Length : 0.8 m (31.5 inches) 	

Table 2-2 BNC cables for the Agilent B2900A series

Model/Option	Description	Additional Information
16493B-001	Coaxial Cable, BNC(m) to BNC(m), 1.5 m	
16493B-002	Coaxial Cable, BNC(m) to BNC(m), 3.0 m	
<p>The maximum voltage is 40 V, and Maximum current is 200 mA. The Agilent 16493B Coaxial Cable is designed for use with VSU (Voltage Source Unit), VMU (Voltage Measurement Unit) or PGU (Pulse Generator Unit) on the Agilent 4155 series Semiconductor Parameter Analyzer.</p>		
16493U-001	High current coaxial cable, BNC(m) to BNC(m), 1.5 m	
16493U-002	High current coaxial cable, BNC(m) to BNC(m), 3.0 m	
<p>The maximum current is 40 A. The 16493U High current coaxial cable is designed for use with HCSMU (High Current SMU) Module on the Agilent B1505A Power Device Analyzer/Curve Tracer.</p>		

WARNING Potentially hazardous voltages, up to ± 250 V are present at the Force, Sense, and Guard terminals.

To prevent electrical shock, do not expose these lines.

WARNING Potentially hazardous voltages of up to ± 250 V may be present at the Low Force and Low Sense terminals also. To prevent electrical shock, use the accessories comply with the IEC 61010-2-031. The terminals and the extended conductors must be isolated by using the insulation cap, sleeve, and such.

WARNING Before turning the B2900A on, connect the Intlk terminal to a switch that turns off when the shielding box access door is opened.
Before you touch any connections to these terminals, turn the B2900A off, disconnect the power cable, and discharge any capacitors.

CAUTION The 16493B Coaxial Cable is designed for use with VSU (Voltage Source Unit), VMU (Voltage Measurement Unit) or PGU (Pulse Generator Unit) on the Agilent 4155/4156 series. (40 V/200 mA). For the safety reason, Agilent do NOT recommend to use any BNC type cables which have common potential on the connector.

CAUTION Never connect the Guard terminal on the B2900A to any output, including circuit common, chassis ground, or any other guard terminal. Doing so will damage the SMU.

NOTE Do not put any conductor on the Low Force and Low Sense terminals of each SMU channels, outer conductor of the coaxial connectors, Putting conductor of circuit common, chassis ground, or any potential on causes the measurement error.

Table 2-3 Triaxial cables for the Agilent B2900A series

Model/Option	Description	Additional Information
16494A-001	Triaxial Cable, 1.5 m	
16494A-002	Triaxial Cable, 3 m	
16494A-003	Triaxial Cable, 80 cm	
16494A-004	Triaxial Cable, 40 cm	
16494A-005	Triaxial Cable, 4 m	

CAUTION

The maximum current rating of the 16494A Triaxial cable is 1A. Do not use the triaxial cable with over 1A. For higher current beyond 1A, It is recommended that U8201A or 11059A with 4-wire connections.

NOTE

For the lower current measurement, use the 16494A Triaxial cable with low-noise environment. This cable can maximize the guard effects and minimize the impression of the external noise.

2.2 Adapters & Connectors

For connecting a DUT, you can choose the connection type 2-wire connection or 4-wire connections. If you want to simplify the connections, use the 2-wire connections by connecting the Force terminals only. Then open the Sense terminals. The Force terminals can be used to apply and measure dc voltage or current.

To make the 4-wire connections, remote sensing, well known as Kelvin connections, uses both Force and Sense terminals. Connecting the Force and Sense lines together at the terminal of the DUT minimizes the measurement error caused by the residual resistance of the test leads or cables. This connection is effective for the low resistance measurement and the high current measurement.

Before connecting to a DUT, specify suitable connection method on the B2900A series and select required adapters.

Figure 2-1

B2900A Front Terminals

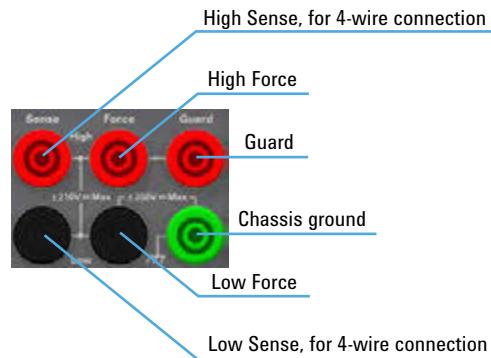
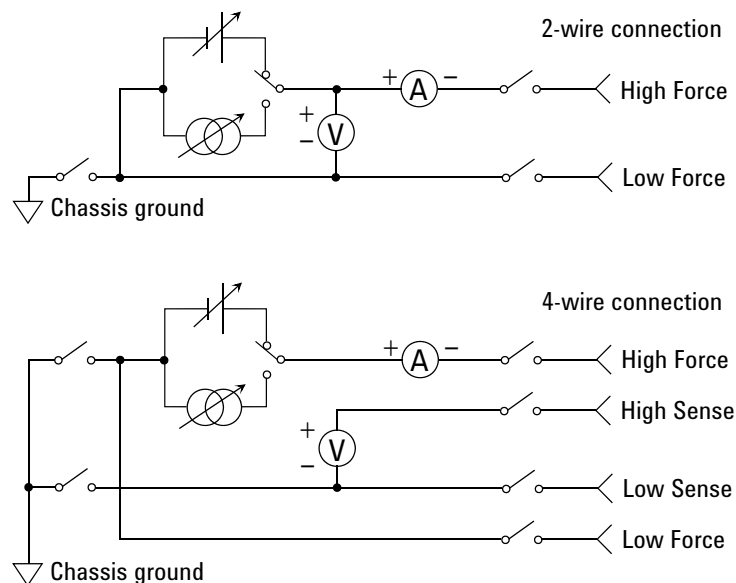





Figure 2-2

Simplified SMU Circuit Diagram



NOTE The following table shows the adapter information provided by Agilent. If you need an adapter which is not provided, contact a local parts vendor.

Table 2-4 Item number information for adapters used with B2900A series

Model/Option	Description	Additional Information
1253-7217	Plug-Banana Double (black)	
1251-2277	Adapter-Banana BNC Jack Plug	
N1294A-001	Banana to Triaxial adapter for 2 wire (non-kelvin) connection	
N1294A-002	Banana to Triaxial adapter for 4 wire (kelvin) connection	

WARNING



There are potentially hazardous voltages (± 210 V) present at the High Force, High Sense, and Guard terminals of Agilent B2900A. To prevent electrical shock, the following safety precautions must be observed during the use of the B2900A.

- Use a three-conductor AC power cord to connect the cabinet (if used) and the B2900A to an electrical ground (safety ground).
- If you do *not* use the Agilent 16442B Test fixture, you must install and connect an interlock circuit that opens the interlock terminal when the shielding box access door is opened.
- Confirm periodically that the interlock function works normally.
- Before touching the connections on the High Force, High Sense, and Guard terminals, turn the B2900 off and discharge any capacitors. If you do *not* turn the B2900 off, complete *all* of the following items, regardless of the B2900 settings on firm periodically that the interlock function works normally.
 - Press the On/Off key, and confirm that the key turns off.
 - Confirm that the On/Off key does not turn red.
 - Open the shielding box access door (open the interlock terminal).
 - Discharge any capacitors connected to a channel.
- Warn persons working around the B2900A about dangerous conditions.

CAUTION

Maximum voltage and current

The test fixture and adapters must be used under the following limitations to prevent damage to them.

Agilent N1294A-001 and 002 Banana to Triax adapter:

± 250 V maximum, ± 42 V maximum for connecting N1295A Small test fixture.

Agilent N1295A Small Test Fixture: ± 42 V, 1.05 A maximum

Figure 2-3

Connection Diagram of N1294A-001 Banana to Triaxial adapter for 2 wire (non-kelvin) connection

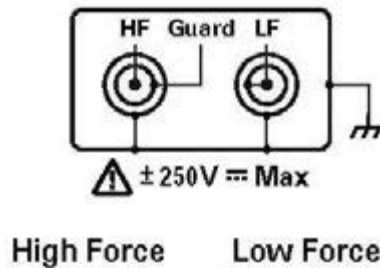
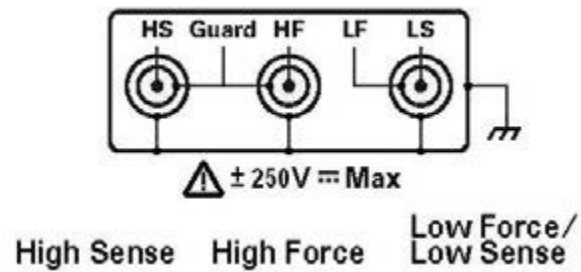

Figure 2-4

Connection Diagram of N1294A-002 Banana to Triaxial adapter for 4 wire (kelvin) connection



2.3 Test Fixture

The Agilent offers the following 3 types of test fixture. Each Test fixture have the specification for maximum voltage and current. For details, refer to the each technical document or user's guide.

- **N1295A Device/component Test Fixture** - has four triaxial connectors for four terminal devices as maximum.
- **U2941A Parametric Test Fixture** - has three BNC input channels and a common ground. You can select different types of socket modules for device-under-test (DUTs) of various pin conjunctions.
- **16442B Test Fixture** - designed for testing packaged device and electronic components. You can mount the suitable socket module on the 16442B, which allows you to easily connect various devices to measurement units.

2.3.1 N1295A Device/component Test Fixture

The Agilent N1295A is a test fixture which has four triaxial connectors which allows to make two 2-wire connections or the 4-wire connections. To connect to the B2900A, 16494A Triaxial cables and either N1294A-001 or 002 banana to triaxial adapter are required.

Table 2-5 N1295A Device/component Test Fixture for the Agilent B2900A series

Model/Option	Description	Additional Information
N1295A	Device/component Test Fixture The N1295A test fixture furnishes with pin clip wire 4 ea. and pin plug wire 2 ea.	 The image shows the Agilent N1295A test fixture, a small metal enclosure with four triaxial connectors on the front. Next to it is a disassembled view of the fixture, showing the internal green PCB and the lid.

CAUTION

Maximum voltage and current

The test fixture and adapters must be used under the following limitations to prevent damage to them.

Agilent N1294A-001 and 002 Banana to Triax adapter:
±250 V maximum, ±42 V maximum for connecting N1295A Small test fixture.

Agilent N1295A Small Test Fixture: ±42 V, 1.05 A maximum

NOTE

Shielding

The N1295A is quipped with the lid. To minimize the affect of ambient noise, close the lid when performing the measurement.

2.3.2 U2941A Test Fixture

The Agilent U2941A test fixture is designed for semiconductor device testing and has three BNC type input channels and a common guard. You can select different types of socket modules for devices-under-test (DUTs) of various pin conjunctions.

To connect to the B2900A, 1253-7217 Plug-Banana Double (black) is required.

Table 2-6 U2941A Parametric Test Fixture

Model/Option	Description	Additional Information
U2941A	<p>Parametric Test Fixture</p> <p>The following items are shipped as standard with the U2941A parametric test fixture.</p> <ul style="list-style-type: none"> • Assembly PTFE plate • 28-pin dual-in-package (DIP) socket module • 0.1-inch universal socket module • 0.075-inch universal socket module • 0.5-inch universal socket module • Pin plug-to-pin plug cables, black (4 pcs) • Pin plug-to-pin plug cables, red (4 pcs) • Pin plug-to-pin plug cables, blue (4 pcs) • Pin plug-to-miniature clip cables, black (4 pcs) • Pin plug-to-miniature clip cables, red (4 pcs) • Pin plug-to-miniature clip cables, blue (4 pcs) • PCB jumper pin • BNC to two-wire cable, 1m (3 pcs) • CD-ROM for Agilent Parametric Measurement Manager 	
U2941A-107 (U2941-61601)	BNC to two-wire cable (1 m)	The U2941A includes three BNC to two-wire cables. If you need additional cables, select this option.

CAUTION

Maximum voltage and current

The test fixture and adapters must be used under the following limitations to prevent damage to them.

Agilent U2941A Parametric test fixture:

±60 V, 1 A maximum

NOTE

Shielding

The U2941A is equipped with the lid. To minimize the affect of ambient noise, close the lid when performing the measurement.

NOTE

Ensure that no voltage or current is applied to the U2941A when attaching the socket module.

2.3.3 16442B Test Fixture

The Agilent 16442B test fixture is designed for testing packaged devices and electronic components. You can mount the suitable socket module on the 16442B, which allows you to easily connect various devices to measurement units.

The 16442B has the following input ports.

- 6 SMU channels (Triaxial connector. It can be used either for 6 non-Kelvin or 3 Kelvin connectors.)
- 2 VSU channels (BNC connector)
- 2 VMU channels (BNC connector)
- 2 PGU channels (BNC connector)
- 1 GNDU channel (Triaxial connector. It requires the Agilent 16493L GNDU cable.)
- 1 interlock 6-pin connector

Table 2-7 16442B Test Fixture

Model/Option	Description	Additional Information
16442B	<p>Test Fixture for Semiconductor Devices</p> <p>The following items are shipped as standard with the 16442B test fixture.</p> <ul style="list-style-type: none"> • Blank PTFE board • 28-pin dual-in-package (DIP) socket module • 0.075-inch universal socket module • 0.5-inch universal socket module • Miniature banana to pin plug cables, black (4 pcs) • Miniature banana to pin plug cables, red (4 pcs) • Miniature banana to pin plug cables, blue (4 pcs) • Pin plug to pin plug cables, black (3 pcs) • Pin plug to pin plug cables, red (3 pcs) • Pin plug to pin plug cables, blue (3 pcs) • Miniature banana to miniature clip cables, black (3 pcs) • Miniature banana to miniature clip cables, red (3 pcs) • Miniature banana to miniature clip cables, blue (3 pcs) • Miniature banana to miniature banana, black (3 pcs) • Miniature banana to miniature banana, red (3 pcs) • Miniature banana to miniature banana, blue (3 pcs) • Connection pin set (10 ea) • Accessory case 	
16442B-010 (16494A-001)	Add four 1.5 m Triaxial cables	If triaxial cables are required, select either 16442B-001 or 16442B-011.
16442B-011 (16494A-002)	Add four 3.0 m Triaxial cables	To connect to the B2900A series, N1294A-001 or 002 Banana to Triaxial adapter is required.

NOTE When the Digital I/O interlock terminal is open, the B2900A cannot apply high voltage over ± 42 V. To Perform the high voltage measurement, the B2900A must be connected to the interlock circuit installed in the 16442B.

2.4 Other I/F and Interlock

2.4.1 Rear Panel

The Agilent B2900A rear panel provides various interfaces. GPIB, USB2.0 and Ethernet (LAN) are used for controlling the B2900A remotely with or without programming. The D-sub 25 pin digital I/O port is general purpose interface. It provides various capabilities used for external control such as trigger input/output, interlock control and handler control signals. It supports to build up a system configured from multiple instruments.

The B2900A has the following Interfaces.

- GPIB Interface
- USB-B Interface
- Digital I/O (D-sub 25 pin)
- Ethernet (10/100 Base-T LAN)
- Channel 2 terminal (B2902A and B2912A only)

CAUTION

Never connect the Guard terminal to any output, including circuit common, chassis ground, or any other guard terminal. Doing so will damage the B2900A.

CAUTION

Maximum current to the chassis ground terminal is 3 A DC.

NOTE

Serial Number

You need the instrument's *serial number* when using the Agilent Technologies telephone assistance program. The serial number label is attached to the bottom of the instrument.

Figure 2-5



B2912A (2-channel model) Rear View



Figure 2-6 Remote control of B2912A by external PC (through USB/LAN/GPIB)



Table 2-8 Item number information for related accessories used with B2900A series

Model/Option	Description	Additional Information
10833A	GBIB cable, 1 m	
10833B	GBIB cable, 2 m	
10833C	GBIB cable, 4 m	
10833D	GBIB cable, 0.5 m	
16493G-001	Digital I/O connection cable, 1.5 m	
16493G-002	Digital I/O connection cable, 3.0 m	
N1294A-011	Interlock cable for 16442B Test Fixture, 1.5 m	
N1294A-012	Interlock cable for 16442B Test Fixture, 3.0 m	

WARNING Potentially hazard voltages of up to ± 210 V may be present at the High Force, High Sense, and Guard terminals when the 16442B test fixture lid is closed. To prevent electrical shock, do *not* expose these lines.

2.4.2 Program and Interface Capabilities

Programming Language

The B2900A series supports SCPI (Standard Commands for Programmable Instruments).

- Default command set: Supports all of the advanced features of the B2900A series
- Conventional command set: Support industry standard conventional SCPI command set for basic compatibility.

Program Memory

Program memory allows you to store long strings of SCPI command lines once into the B2900A series' volatile memory and then recall those strings multiple times while the program is executing using a single SCPI command. By storing the command strings in memory, the time that would have been spent sending those same commands over a communication bus is eliminated. For tests that utilize lots of repeated code (such as subroutines), program memory can dramatically reduce test times.

- Maximum number of characters of program name: 32 with alphabets, numbers, hyphens, and underscores
- Maximum memory size: 100 kB (2500 lines typical)

LXI

LXI Class-C compliant. The B2900A series follows specified LAN protocols and adhere to LXI requirements such as a built-in Web control server and IVI-COM driver.

- Ethernet: 10/100Base-T
- USB2.0: USB-TMC488 protocol (rear × 1)
- GPIB: IEEE-488.2 compliant

USB File System

USB 2.0 high-speed mass storage (MSC) class device (front × 1)

Digital I/O Interface

DSUB 25 pin female connector for general purpose I/O (GPIO). Can be used for the trigger input/output terminals or an interface to a handler and so on.

- Connector: 25-pin female D
- Input/output pins: 14 open drain I/O bits
- Absolute maximum input voltage: 5.25 V
- Absolute minimum input voltage: -0.25 V
- Maximum logic low input voltage: 0.8 V
- Maximum logic high input voltage: 2.0 V
- Maximum source current: 1 mA, Vout = 0 V
- Maximum sink current: 50 mA, Vout = 5 V

- 5 V power supply pin:
Limited to 600 mA, solid state fuse protected
- Safety interlock pin:
One active high pin and one active low pin. Activation of both pin enables output voltage > 42 V.

2.4.3 Installing the Interlock Circuit

The B2900A cannot apply high voltage over ± 42 V when the Digital I/O interlock terminal is open. To perform high voltage measurement, the B2900 interlock terminal must be connected to the interlock circuit installed in the measurement environment such as the shielding box. The interlock circuit is important and necessary to prevent electrical shock when an user touches the measurement terminals.

Pin 16 and 24 are reserved for the interlock function. If the terminals are open, the instrument output is limited to ± 42 V. Be sure to connect the terminals to the Agilent 16442B test fixture or another DUT interface before performing measurement. If you do not use the 16442B, you need to install an interlock circuit as shown in Figure 2-7.

Please refer to the “Installing the Interlock Circuit” in the *Agilent B2900A Series User's Guide* for the details.

Figure 2-7 An example of Interlock Circuit

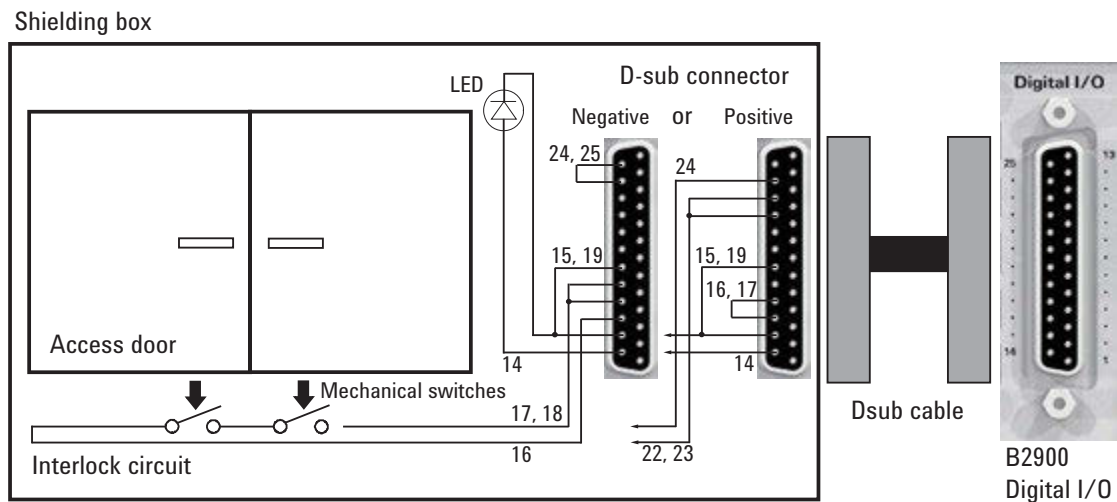

2.5 Rack Installation

Agilent B2900A series can be mounted in a 19-inch EIA rack cabinet. It is designed to fit in two rack-units (2U) of space.

Remove the handle and the front and rear rubber bumpers before rack mounting the B2900A. Do not block the air intake at the sides and the exhaust at the rear of the B2900A.

1. To Remove the Bumper

Stretch a corner of the rubber bumper and slide it off.

2. To Remove the Handle

- Grasp the handle by the sides and pull outward. This allows you to rotate it.
- Rotate the handle to a vertical position. Then put the instrument horizontally.
- Pull outward and then lift the handle upward.

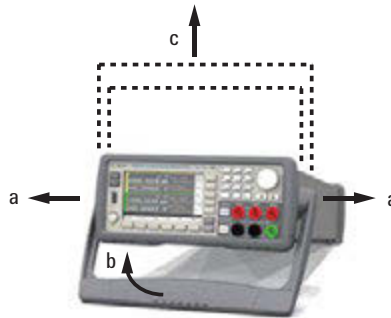

CAUTION

To put the handle back again, be careful about its direction. Putting it in the wrong direction may damage it.

3. Attach Rack mount kit. Be sure to use the support rails in the rack cabinet.

To rack mount a single instrument, Order an option 1CM on the B2900A series or the Agilent 34190A Rack mount Kit (5063-9240).

To rack mount two instruments side-by-side, order the Agilent 34194A Dual lock-link kit (5061-8769) and the 34191A 2U Dual flange kit (5063-9212).

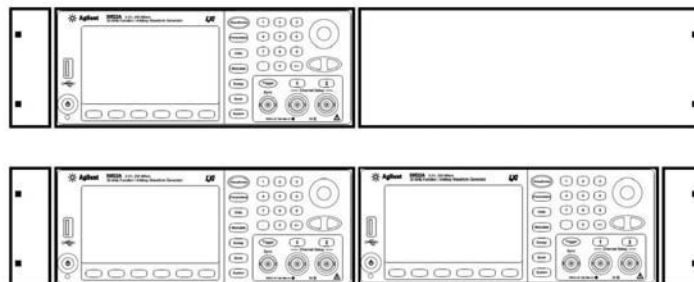

CAUTION

In order to prevent overheating, do not block the flow of air into or out of the instrument. Be sure to allow enough clearance at the rear, sides, and bottom of the instrument to permit adequate internal air flow.

3 Connection

3.1 Connecting to a DUT

This section describes how to connect a device under test (DUT) to the Agilent B2900A series.

3.1.1 “2-wire connections” or “4-wire connections”

For connecting a DUT, you can choose the connection type 2-wire connections or 4-wire connections.

If you want to simplify the connection, use the 2-wire connections by connecting the Force terminals only. Then open the Sense terminals. The force terminals can be used to apply and measure dc voltage or current.

For the low resistance measurement and the high current measurement, use the 4-wire connections. To make the 4-wire connections, remote sensing, well known as the Kelvin connections, use both Force and Sense terminals. Connecting the Force and Sense lines together at the terminal of the DUT minimizes the measurement error caused by the residual resistance of the test leads or cables.

Figure 3-1 2-wire and 4-wire connections

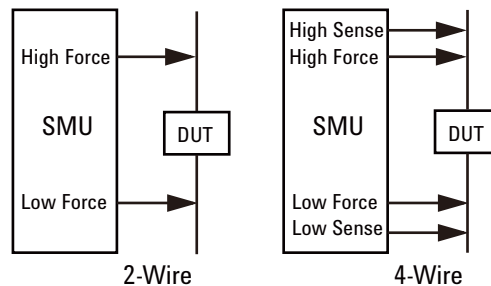

NOTE Kelvin connections (4-wire) give good measurement results when you force high-current, The following figure shows the equivalent circuits for Kelvin and non-Kelvin connections.

Figure 3-2 Residual resistance on the Resistance measurement

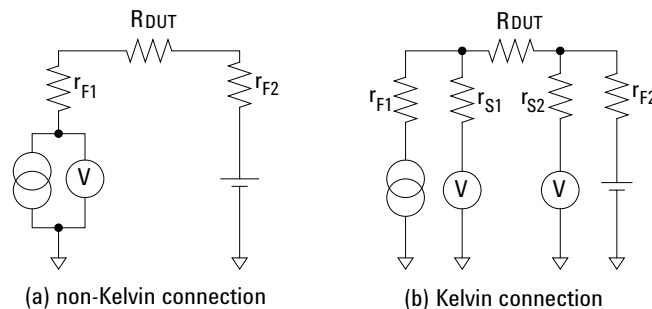

3.1.2 Floating

In the default setting, the Low Force and Low Sense terminals are connected to the chassis ground. However, they can be disconnected from the ground for the floating measurements.

This setup is effective for differential voltage measurements which usually require two channels as shown in the Grounded 2 connection.

Figure 3-3 Grounded and Floating measurement

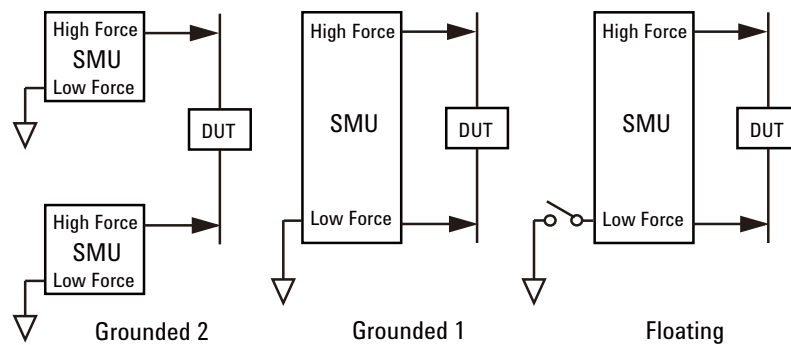

CAUTION

Maximum current to the chassis ground is 3 A DC.

WARNING

Potentially hazardous voltages of up to ± 210 V may be present at the Low Force and Low Sense terminals. To prevent electrical shock, use the accessories comply with the ICE 61010-20-031. The terminals and the extended conductors must be isolated by using the insulation cap, sleeve, etc.

3.1.3 To use Test Leads

Type of the B2900A source/measure terminals is the banana jack. For connecting a DUT, the U8201A Combo Test Lead Kit or the 11059A Kelvin Probe Set is available. The following Figure shows the connections for the two-terminal device measurements.

Figure 3-4 Connecting a Two-Terminal Device

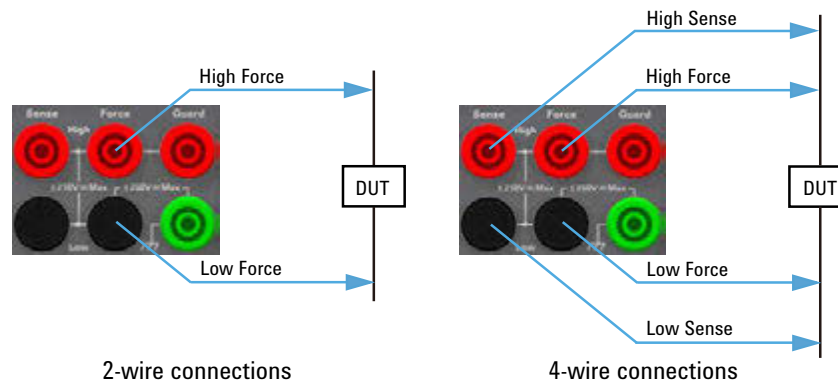

3.2 Connection with Test Fixture

This section describes how to connect with Test Fixture to the Agilent B2900A source/measure terminals. For details of each fixture, refer to the user's guide of each test fixtures also.

3.2.1 To use N1295A Test Fixture

The Agilent N1295A is a test fixture which has four triaxial connectors which supports 2-wire connections. To connect the N1295A to the B2900A source/measure terminals, the Agilent N1294A-001 banana to triaxial adapter for the 2-wire connection is required.

- **Connection example for two terminals device**

To connect to the N1295A test fixture for the device of two terminals, two 16494A Triaxial cables are required.

Figure 3-5 Agilent N1295A connection example for the device with two terminals

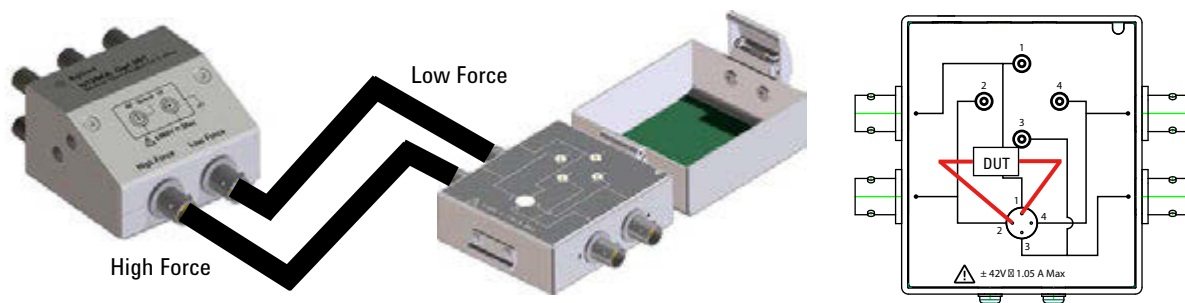

- **Connection example for three terminals device by 2 channels of SMU**

To connect to the N1295A test fixture for the device of three terminals such as Bipolar Junction Transistor (BJT), four 16494A Triaxial cables are required.

Figure 3-6 Connection circuit for BJT (NPN) by 2 channels of SMU

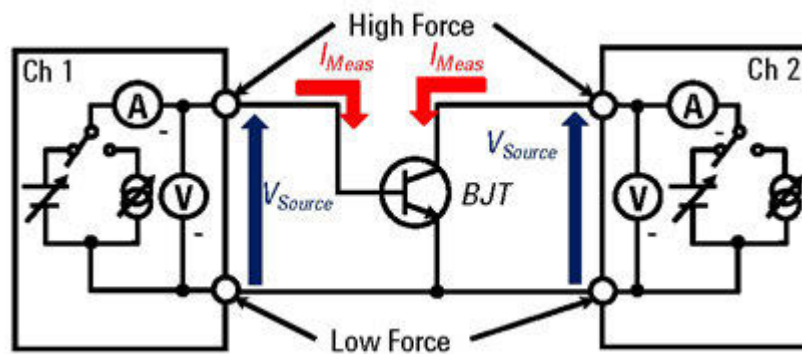
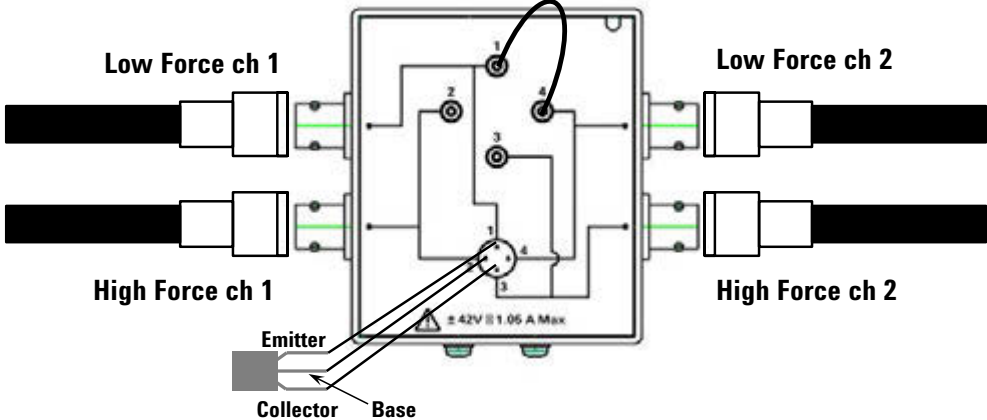

Figure 3-7 Agilent N1295A connection example for the BJT (NPN) by 2 channels of SMU



CAUTION

Maximum voltage and current

The test fixture and adapters must be used under the following limitations to prevent damage to them.

Agilent N1294A-001 Banana to Triax adapter:
±250 V maximum, ±42 V maximum for connecting N1295A Small test fixture.

Agilent N1295A Small Test Fixture: ±42 V, 1.05 A maximum

NOTE

Shielding

The N1295A is equipped with the lid. To minimize the affect of ambient noise, close the lid when performing the measurement.

NOTE

4-wire connections are not supported on the N1295A and B2900A.

3.2.2 To use U2941A Test Fixture

The Agilent U2941A test fixture is designed for semiconductor device testing and has three BNC type input channels and a common guard. You can select different types of socket modules for devices-under-test (DUTs) of various pin conjunctions. See *Agilent U2941A Parametric Test Fixture Operating Guide* for details and accessories of the U2941A.

To connect to the B2900A source/measure terminals, 1253-7217 Plug-Banana Double (black) is required.

- **Connection example for 2-wire Connections**

To connect to the U2941A test fixture for 2-wire connections, one BNC to two-wire cable (U2941-61601) and one Plug-Banana Double adapter (1253-7217) are required.

Attach the plug-banana double adapter to High Force and Low Force terminals on the B2900A Channel 1 terminal.

Figure 3-8 Agilent U2941A connection example for 2-wire connections

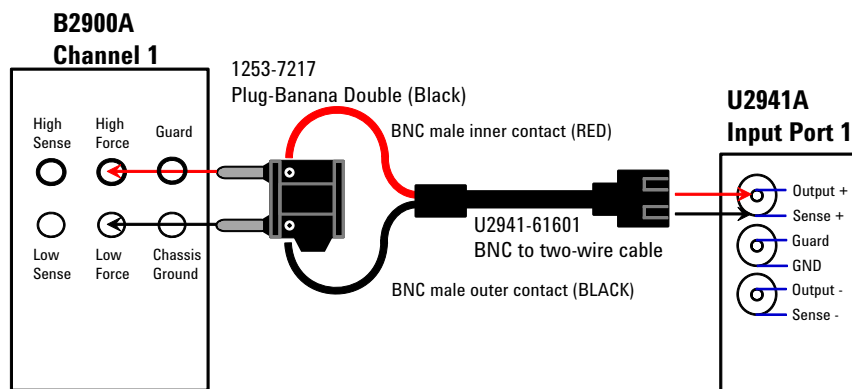
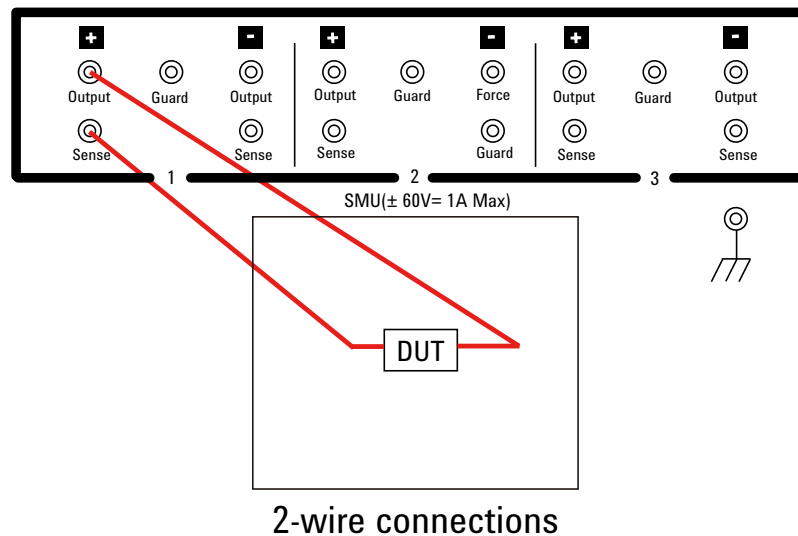

Figure 3-9 U2941A Wiring Panel



- **Connection example for 4-wire Connections**

To connect to the U2941A test fixture for 4-wire connections, two BNC to two-wire cable (U2941-61601) and two Plug-Banana Double adapter (1253-7217) are required.

Attach the plug-banana double adapters to the B2900A source/measure terminals (High Force, Low Force, Low Force and Low Sense) as shown in the following figure.

Figure 3-10 Agilent U2941A connection example for 4-wire connections

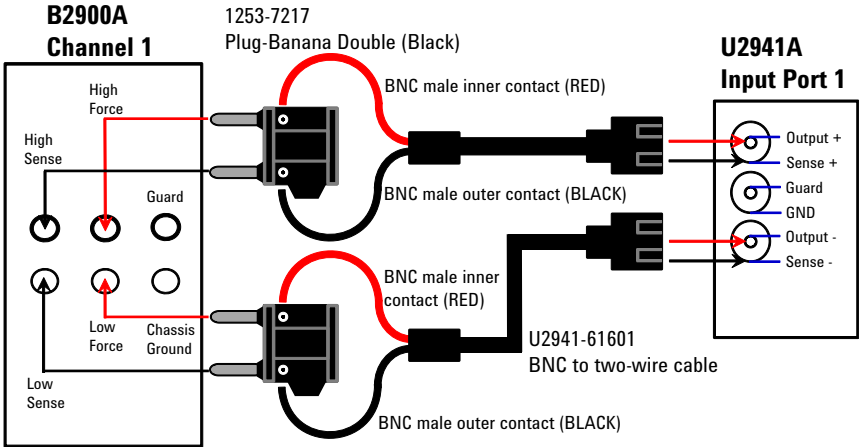
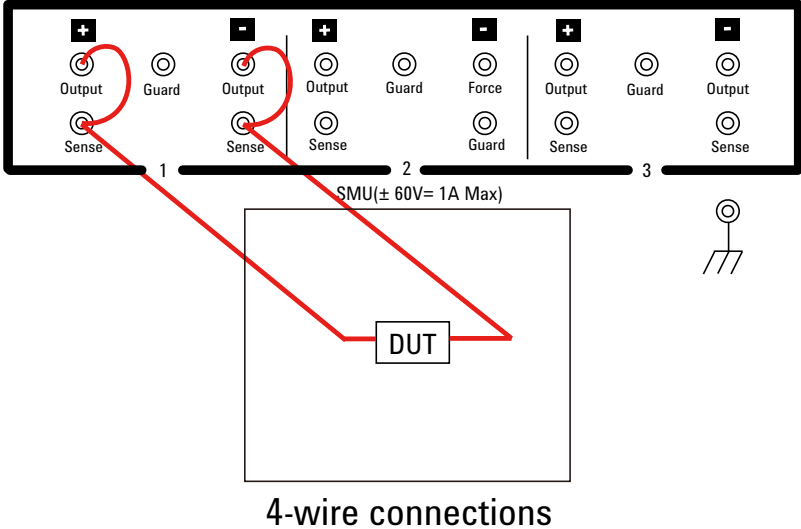

Figure 3-11 U2941A Wiring Panel



WARNING Dangerous voltage of up to the maximum voltage of SMUs may be present at force, guard and sense terminals if the Interlock terminal is closed.

WARNING To avoid electrical shock and instrument damage, do not connect or disconnect measurement cable during operation.

3.2.3 To use 16442B Test Fixture

The Agilent 16442B test fixture is designed for testing packaged devices and electronic components. The 16442B has six triaxial connectors for source/measure unit (SMU), the GNDU connector for the ground unit of a parameter/device analyzer, the Interlock connector for the interlock control, and six coaxial (BNC type) connectors for other instruments. You can mount the suitable socket module on the 16442B, which allows you to easily connect various devices to measurement units. See *Agilent 16442B Test Fixture User's Guide* for details and accessories of the 16442B.

To connect to the B2900A source/measure terminals, N1294A-001 or 002 Banana to Triaxial adapter is required.

- **Connection example for 2-wire Connections**

To connect to the 16442B test fixture for 2-wire connections, N1294A-001 banana to triaxial adapter for 2 wire (non-kelvin) connection and two 16494A triaxial cables are required.

Attach the banana to triaxial adapter to the B2900A source/measure terminals.

Connect the triaxial cables between the adapter and the 16442B as shown in the following figure.

Figure 3-12 Agilent 16442B connection example for 2-wire connections

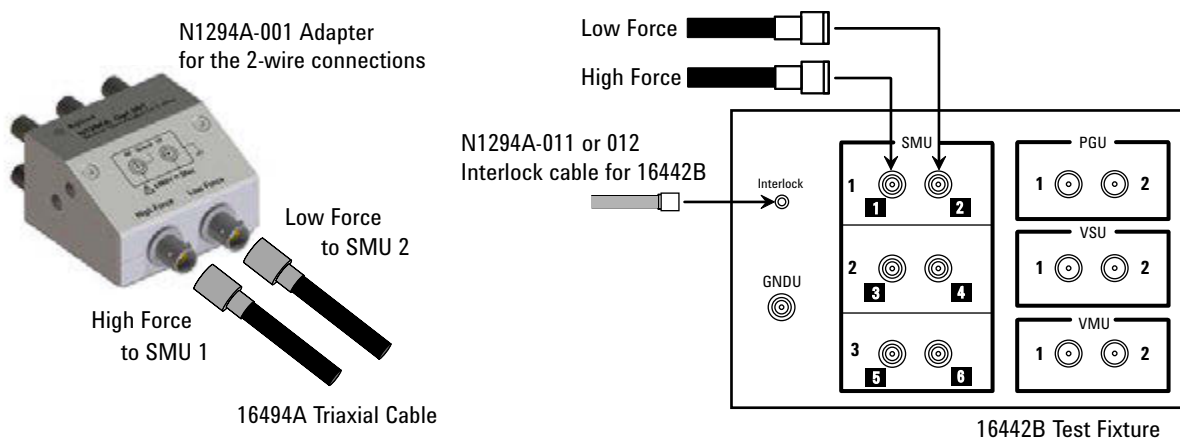
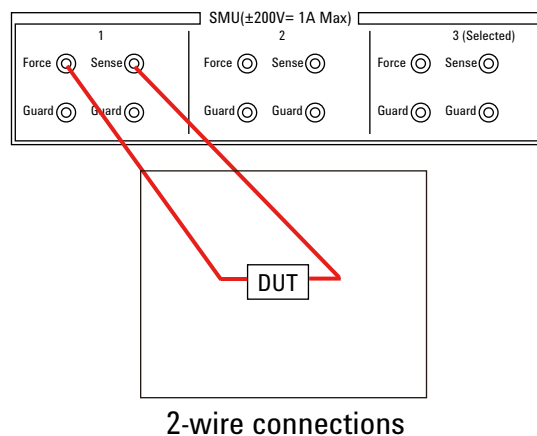

Figure 3-13 16442B Wiring Panel (2-wire connections)



- **Connection example for 4-wire Connections**

To connect to the 16442B test fixture for 4-wire connections, N1294A-002 banana to triaxial adapter for 4 wire (kelvin) connection and three 16494A triaxial cables are required.

Attach the banana to triaxial adapter to the B2900A source/measure terminals.

Connect the triaxial cables between the adapter and the 16442B as shown in the following figure.

Figure 3-14 Agilent 16442B connection example for 4-wire connections

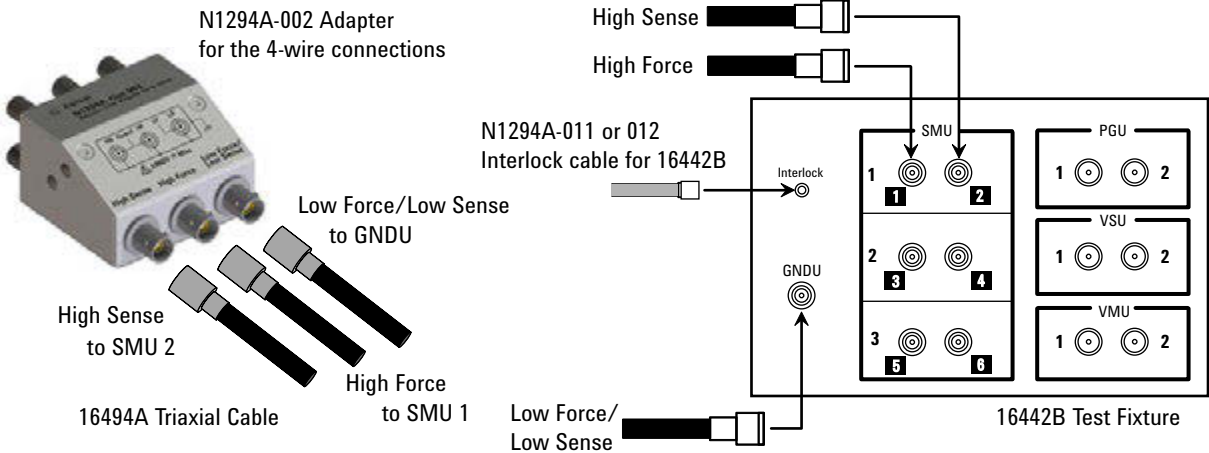
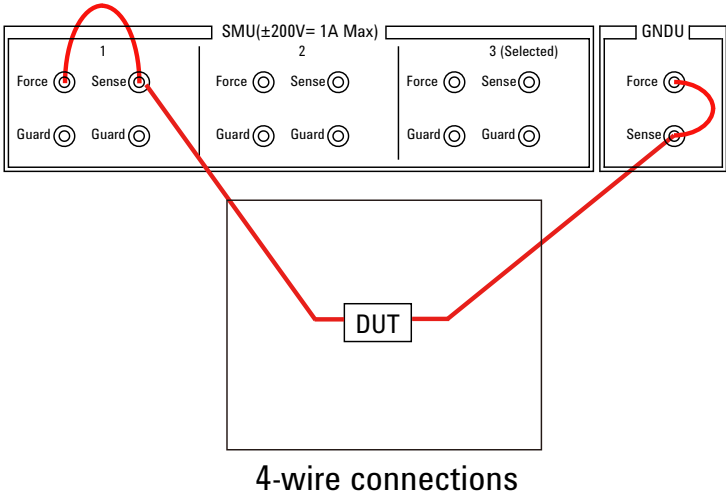

Figure 3-15 16442B Wiring Panel (4-wire connections)



- **Connection example for three terminals device by 2 channels of SMU**

To connect to the 16442B test fixture for three terminals device by 2 channels of SMU, two sets of N1294A-001 banana to triaxial adapter for 2 wire (non-kelvin) connection and four 16494A triaxial cables are required.

Attach the banana to triaxial adapter to the B2900A source/measure terminals.

Connect the triaxial cables between the adapter and the 16442B as shown in the following figure.

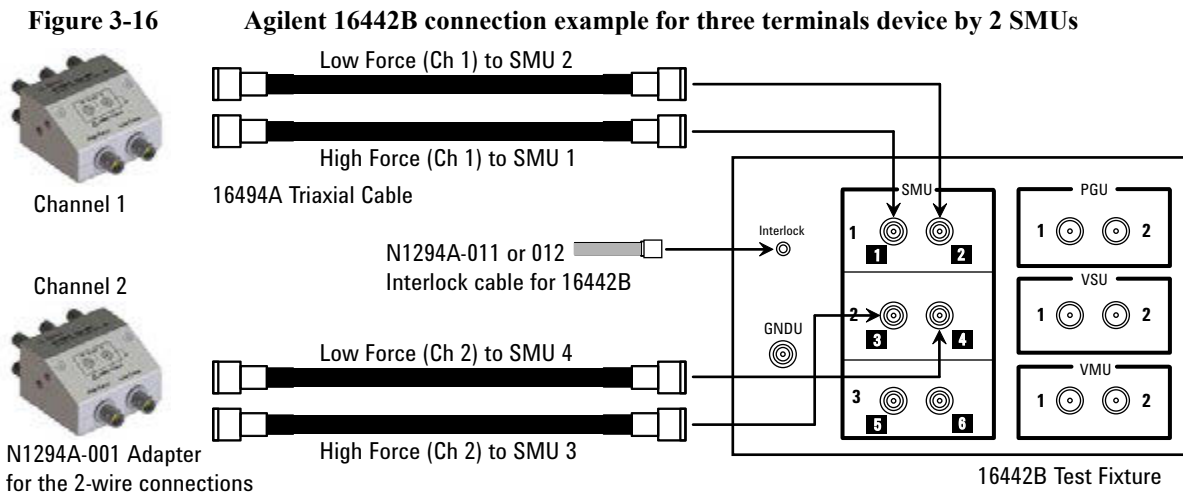
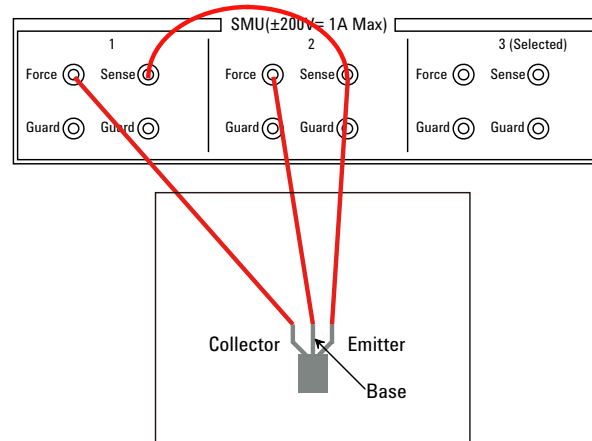

Figure 3-17 16442B Wiring Panel (BJT (NPN) by 2 channels of SMU)



Connections for BJT (NPN)

CAUTION

Maximum voltage and current

The test fixture and adapters must be used under the following limitations to prevent damage to them.

Agilent N1294A-001 and 002 Banana to Triax adapter:
 ±250 V maximum, ±200 V maximum for connecting 16442B test fixture.

Agilent 16442B Test Fixture: ±200 V, 1 A maximum for SMU input

NOTE**Shielding**

The 16442B is quipped with the lid. To minimize the affect of ambient noise, close the lid when performing the measurement.

NOTE**Performing high voltage measurement**

When the Digital I/O interlock terminal is open, the B2900A cannot apply high voltage over ± 42 V. To perform the high voltage measurement, the B2900A must be connected to the interlock circuit installed in the 16442B.

Prepare the N1294A-011 or 012 interlock cable. And connect it between the B2900A Digital I/O connector and the 16442B Interlock connector. The B2900A can apply the high voltage when the test fixture lid is closed.

WARNING

Potentially hazardous voltages of up to ± 210 V may be present at the High Force, High Sense, and Guard terminals when the 16442B test fixture lid is closed. To prevent electrical shock, do *not* expose these lines.

3.3 Connection with Prober

This section describes information on how to connect a prober to the B2900A series Precision Source / Measure Unit.

3.3.1 Connecting to Manual Prober

High Force and Low Force terminal on the N1294A-001 banana to triaxial adapter for 2-wire have FORCE (SENSE), GUARD, and COMMON output as shown Figure 3-18. High Force and High Sense on the he N1294A-002 banana to triaxial adapter for 4-wire also have same output terminals as shown Figure 3-18. However, Low Force and Low Sense of the N1294A-002 banana to triaxial adapter for 4-wire have SENSE, FORCE, and COMMON as shown in Figure 3-19.

Figure 3-18 High Force, High Sense and Low Force of N1294A-001

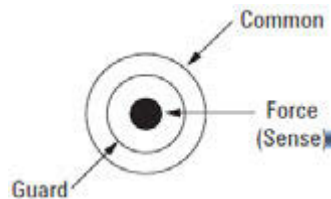
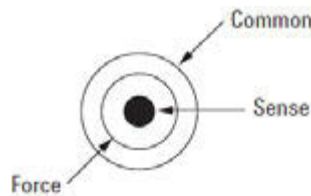

Figure 3-19 Low Force & Low Sense terminals on the N1294A-002



2-wire (Non-Kelvin) connection

These instructions apply when all connections are 2-wire (non-Kelvin) connection for wafer prober. Connect the Agilent 16494A triaxial cables between the N1294A-001 banana to triaxial adapter for 2-wire on the B2900A and the Connector plate. Connect the triaxial connector on the probe cable as shown in Figure 3-20.

Figure 3-20 Example of 2-wire (non-Kelvin) connection

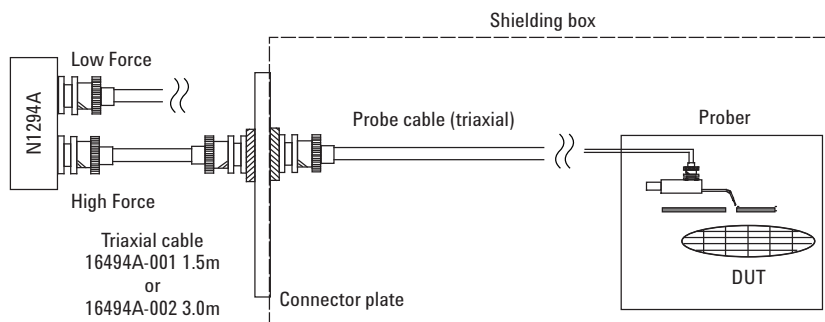

4-wire (Kelvin) connection for High Force and High Sense

These instructions apply when all connections are Kelvin. Two probes must contact the wafer in this connection. Connect two Agilent 16494A triaxial cables between the High Force and High Sense Terminals on the N1294A-002 banana to triaxial adapter for 4-wire and the connector plate. Connect the FORCE and SENSE lines to probes separately. Connect the triaxial connector on the probe cable as shown in Figure 3-21.

NOTE To prevent oscillations, use triaxial cables as short as possible, if two 16494A triaxial cables with Kelvin connections are used.

Figure 3-21 Example of 4-wire (Kelvin) connection for High Force and High Sense

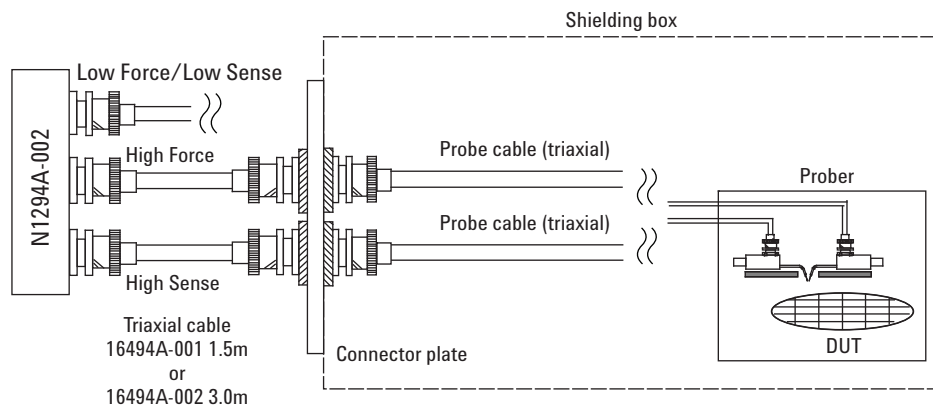

4-wire (Kelvin) connection for Low Force and Low Sense

Connect the triaxial connector using an adapter for GNDU (N1254A-107) as shown in Figure 3-22. This adapter connects Force Terminal and Sense Terminal to the center conductor. For parts information for this connection, see Table 3-1.

Figure 3-22 Example of 4-wire (Kelvin) connection for Low Force and Low Sense

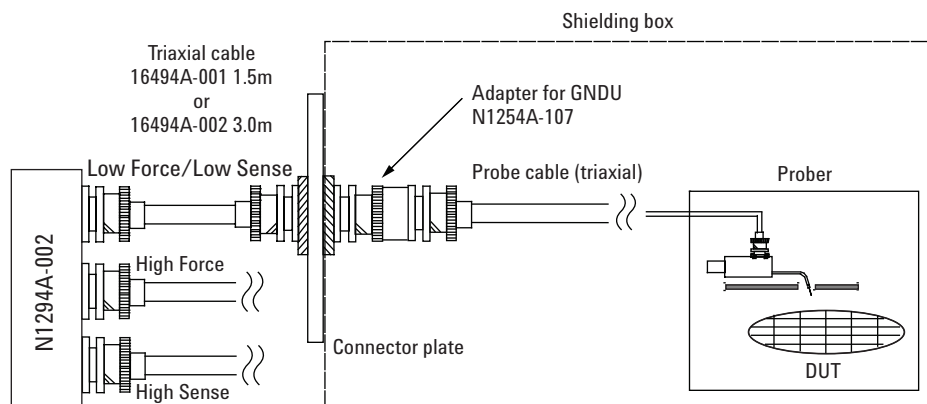

Table 3-1 Item number information for 4-wire (Kelvin) connection for the Low terminal

Description	Qty	Product Number	Part number
Triaxial Cable (1.5 m) - Max 1.0 A	1	16494A-001	N/A
Triaxial Cable (3.0 m) - Max 1.0 A	1	16494A-002	N/A
Triax (m) to Triax (f) adapter	1	N1254A-107	1250-2654

Kelvin to non-Kelvin connection

These instructions apply when the connections up to the Connector Plate are Kelvin, but the probe is a non-Kelvin connection. Connect two Agilent 16494A triaxial cables between the N1294A-002 banana to triaxial adapter for 4-wire and the connector plate. Connect the triaxial connector on the probe cable as shown in Figure 3-23. Connect the FORCE and SENSE lines on this side of the probe input terminal. A Tee Triaxial BNC adapter can be used. For parts information, see Table 3-2.

NOTE To prevent oscillations, use triaxial cables as short as possible, if two 16494A triaxial cables with Kelvin connections are used.

NOTE When connecting the cable and tee connector as shown in Figure 3-23, space restrictions make an adjacent connector unusable. Since three connectors are necessary for a Kelvin connection a connector plate must be used. Select the correct connector plate for your application.

Figure 3-23 Example of Kelvin to non-Kelvin connection

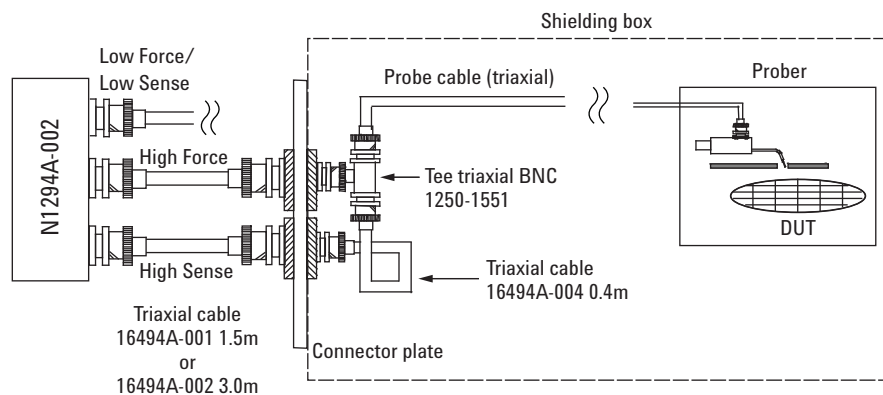

Table 3-2 Item number information for Kelvin to non-Kelvin connection with B2900A

Description	Qty	Product Number	Part number
Triaxial Cable (1.5 m) - Max 1.0 A	2	16494A-001	N/A
Triaxial Cable (3.0 m) - Max 1.0 A	2	16494A-002	N/A
Triaxial Cable (0.4 m)	1	16494A-004	N/A
Triaxial tee-connector	1	N/A	1250-1551

3.3.2 To make connection to reduce leakage current

To reduce the leakage current caused by connection cables, the guard technique is effective. Connect the probing needles to the coaxial cables as shown below:

Guarding reduces the leakage current between the instrument and a DUT. This is important when you measure low current.

1. Cut and trim end of the coaxial cable so that the center conductor does not touch the outer conductor (connected to the guard terminal).
2. Connect the center conductor to tail of the probing needle. Never connect the outer conductor to the probing needle. However, the outer conductor should be extended as close as possible to the probing needle.
3. Connect the outer conductor to the outer conductor of the probing needle if it is a coaxial probing needle.

The following example connection can be used to reduce the leakage current. Extend the outer conductor as close as possible to the probing needle, This is also reduces the induced noise.

Figure 3-24

Cable and Probing needle

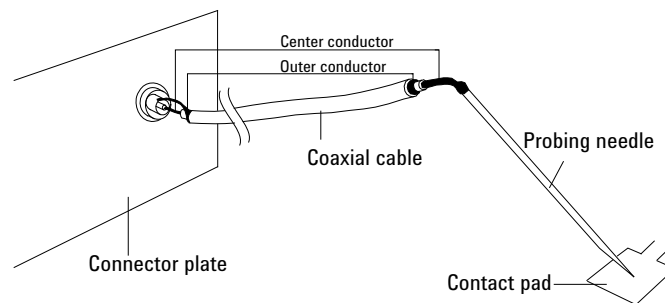

Guarding

Guarding reduces the leakage current between the instrument and the measurement point. This is important when you measure low current.

The following figure shows the theory of guarding. The buffer amplifier ($\times 1$) keeps the potential of the guard conductor at the same potential as the force conductor, so current does not flow between the force and guard conductors. Therefore, the current measured by the instrument is same as current at the DUT terminal because no current is leaked.

Figure 3-25

Guarding

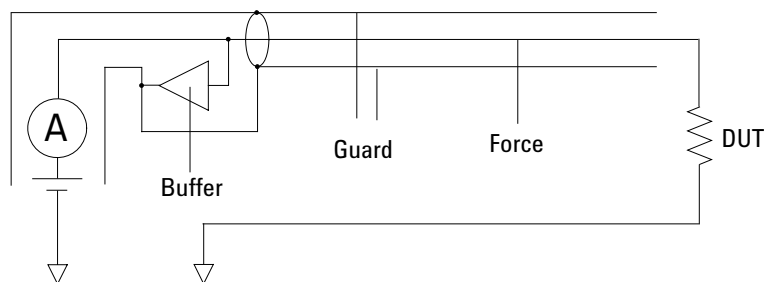

3.3.3 To make connection to measure low resistance

When you measure a low resistance, high current flows through the DUT. This high current increases the measurement error caused by the residual resistance of cables. To cancel the effect of this resistance, you can use Kelvin connections (4-wire), which means the Force and Sense lines are extended separately to the DUT.

Connect the probing needles to the coaxial cables as shown below:

1. Cut and trim end of the coaxial cable so that the center conductor does not touch the outer conductor (connected to the guard terminal).
2. Connect the center conductor to tail of the probing needle. Never connect the outer conductor to the probing needle. However, the outer conductor should be extended as close as possible to the probing needle.
3. Connect the outer conductor to the outer conductor of the probing needle if it is a coaxial probing needle.
4. Perform 1 to 3 for both Force and Sense lines.
5. Contact the probing needles for the Force and Sense lines as close as possible to the DUT.

The following example connection can be used to measure low resistance. The Sense line is extended to the probing pad, and contacts the Force line through the pad, so the voltage drop due to the residual resistance caused by cables and test leads is canceled.

Figure 3-26

Cable and Probing needle

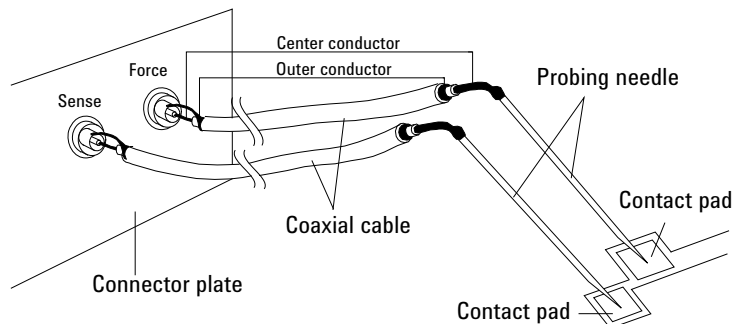

Kelvin Connection

Kelvin connections give good measurement results when you force high-current. The following figure shows the equivalent circuits for Kelvin and non-Kelvin connections.

Figure 3-27

Kelvin connection

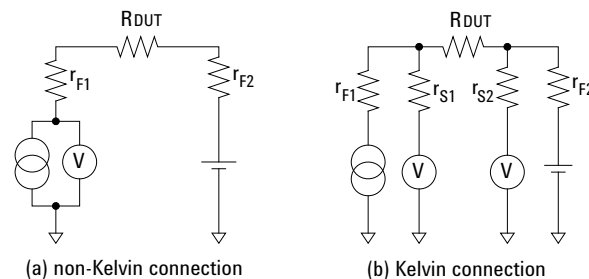

- For the non-Kelvin connection, the voltmeter measures the voltage drop of resistance r_{F1} , R_{DUT} , and r_{F2} .
- For the Kelvin connection, the voltmeter measures the voltage drop of resistance R_{DUT} only. The impedance of the voltmeter is very high, so the voltage drop of resistances r_{S1} and r_{S2} can be ignored.

The Kelvin connection is effective even when forcing voltage. The voltage drop due to the residual resistance of the Force line wiring is fed back to the voltage source via a comparator in the Sense line. The input impedance of comparator is high, and current flow into the Sense line is very low. So output error is not significant if the Sense line wiring has a residual resistance of 10 Ω or less. Therefore, the specified voltage appears at the sense point (point where Sense line contacts Force line).

WARNING

Do not touch the guard terminal with bare hands because you may be shocked by high voltage. The potential of the guard terminal is equal to the output voltage.

CAUTION

Never connect the Guard terminal to any other output, including circuit common, chassis ground, or any other guard terminal. Doing so will damage the B2900A.

NOTE

Kelvin connection and non-Kelvin connection

To make the Kelvin connection, use both Force and Sense terminals. Connecting the Force and Sense lines together at the terminal of the DUT (device under test) minimizes the measurement error caused by the residual resistance of the connection cables. The Kelvin connection is effective for the low resistance measurement and the high current measurement.

If you want to simplify the cable connections, use the 2-wire connections by connecting the Force terminals only. Then open the Sense terminals. This is the non-Kelvin connection. The Force terminals can be used to force and measure dc voltage or current.

Connection
Connection with Prober



4

Ordering Examples

4.1 Agilent B2900A for Resistance measurement

Making accurate resistance measurements is actually one of the more challenging areas of measurement science. Many factors can affect the accuracy of a resistance measurement, including residual test lead resistance, thermal electromotive force and leakage currents in the measurement path. The B2900A Series possesses a variety of features to address these measurement issues, including a remote sense function (4-wire connection), offset compensation, and a guard function.

For details, refer to the Technical Overview, Resistance Measurement by B2900A (5990-6633EN).

Table 4-1 Agilent B2901A with basic test leads (2-wire connections)

Model/Option	Quantity	Description
B2901A	1	Precision Source/Measure Unit, 1ch, 100 fA, 210 V, 3 A DC/10.5A pulse
U8201A	1	Combo Test Lead Kit

Table 4-2 Agilent B2901A with basic test leads (4-wire connections)

Model/Option	Quantity	Description
B2901A	1	Precision Source/Measure Unit, 1ch, 100 fA, 210 V, 3 A DC/10.5 A pulse
11059A	1	Kelvin Probe Set

Table 4-3 Agilent B2901A with U2941A Test Fixture (4-wire connections)

Model/Option	Quantity	Description
B2901A	1	Precision Source/Measure Unit, 1ch, 100 fA, 210 V, 3 A DC/10.5 A pulse
1253-7217	2	Plug-Banana Double (black)
U2941A	1	Parametric Test Fixture

Table 4-4 Agilent B2901A with 16442B Test Fixture (4-wire connections)

Model/Option	Quantity	Description
B2901A	1	Precision Source/Measure Unit, 1ch, 100 fA, 210 V, 3 A DC/10.5 A pulse
N1294A-002	1	Banana to Triaxial adapter for 4 wire (kelvin) connection
16442B	1	Test Fixture for Semiconductor Devices
16494A	3	Triaxial Cable
N1294A-011 (012)	1	Interlock cable for 16442B Test Fixture, 1.5 m (3.0 m)

NOTE 16494A triaxial cable has several options for cable length. Specify cable option and quantity.

4.2 Agilent B2900A for LED IV Measurement

The energy efficiencies and durability of light emitting diodes (LEDs) have led to their increased usage in a variety of applications such as lighting, display panels, etc. This has also spawned research into new types of LEDs with even higher energy efficiencies and properties tailored for specific applications. The B2900A Series enables you to make a wide range of current versus voltage (IV) measurements more accurately and quickly.

Table 4-5 Agilent B2911A with N1295A small test fixture (2-wire connections)

Model/Option	Quantity	Description
B2911A	1	Precision Source/Measure Unit, 1ch, 10 fA, 210 V, 3 A DC/10.5 A pulse
N1294A-001	1	Banana to Triaxial adapter for 2 wire (non-kelvin) connection
N1295A	1	Device/component Test Fixture
16494A	2	Triaxial Cable

Table 4-6 Agilent B2911A with 16442B Test Fixture (2-wire connections)

Model/Option	Quantity	Description
B2911A	1	Precision Source/Measure Unit, 1ch, 10 fA, 210 V, 3 A DC/10.5 A pulse
N1294A-001	1	Banana to Triaxial adapter for 2 wire (non-kelvin) connection
16442B	1	Test Fixture for Semiconductor Devices
16494A	2	Triaxial Cable

Table 4-7 Agilent B2911A and accessories for Manual Prober (2-wire connections)

Model/Option	Quantity	Description
B2911A	1	Precision Source/Measure Unit, 1ch, 10 fA, 210 V, 3 A DC/10.5 A pulse
N1294A-001	1	Banana to Triaxial adapter for 2 wire (non-kelvin) connection
16494A	2	Triaxial Cable

Table 4-8 Agilent B2911A and accessories for Manual Prober (4-wire connections)

Model/Option	Quantity	Description
B2911A	1	Precision Source/Measure Unit, 1ch, 10 fA, 210 V, 3 A DC/10.5 A pulse
N1294A-002	1	Banana to Triaxial adapter for 4 wire (non-kelvin) connection
16494A	3	Triaxial Cable

NOTE 16494A triaxial cable has several options for cable length. Specify cable option and quantity.

4.3 Agilent B2900A for LIV Test of Laser Diode

The light-current-voltage (LIV) sweep test is a fundamental measurement to determine the operating characteristics of a laser diode (LD). In the LIV test, current applied to the laser diode is swept and the intensity of the resulting emitted light is measured using a photo detector (PD).

The B2902A and B2912A have two SMU channels, and each channel possesses accurate IV measurement capabilities as well as the ability to supply either constant or swept voltage/current. The B2902A and B2912A excellent choices for laser diode LIV testing.

For details, refer to the Technical Overview, LIV Test of Laser Diode by B2900A (5990-7115EN).

Table 4-9 Agilent B2902A with N1295A small test fixture (2-wire connections)

Model/Option	Quantity	Description
B2902A	1	Precision Source/Measure Unit, 2ch, 100 fA, 210 V, 3 A DC/10.5 A pulse
N1294A-001	2	Banana to Triaxial adapter for 2 wire (non-kelvin) connection
N1295A	1	Device/component Test Fixture
16494A	4	Triaxial Cable

Table 4-10 Agilent B2902A with 16442B Test Fixture (2-wire connections)

Model/Option	Quantity	Description
B2902A	1	Precision Source/Measure Unit, 2ch, 100 fA, 210 V, 3 A DC/10.5 A pulse
N1294A-001	2	Banana to Triaxial adapter for 2 wire (non-kelvin) connection
16442B	1	Test Fixture for Semiconductor Devices
16494A	4	Triaxial Cable
N1294A-011 (012)	1	Interlock cable for 16442B Test Fixture, 1.5 m (3.0 m)

NOTE 16494A triaxial cable has several options for cable length. Specify cable option and quantity.

4.4 Agilent B2900A for Diode/LED/OLED/Varistor Test

To ensure compliance with manufacturing specifications, single-point pass/fail DC testing must be performed on packaged devices. Because these tests are also used to identify and remove defective devices before shipment, their reliability is important to guarantee product quality. In addition, it is also essential to perform the tests quickly to keep the production throughput high.

The B2900A Series also has many features that make it well-adapted for production test, such as pass/fail binning, a digital I/O interface for handler control, and code compatibility with standard single channel SMU products.

Table 4-11 Agilent B2901A and accessories for production test (1 channel)

Model/Option	Quantity	Description
B2901A	1	Precision Source/Measure Unit, 1ch, 100 fA, 210 V, 3 A DC/10.5 A pulse
N1294A-001	1	Banana to Triaxial adapter for 2 wire (non-kelvin) connection
16494A	2	Triaxial Cable
16493G	1	Digital I/O connection cable

Table 4-12 Agilent B2902A and accessories for production test (2 channels)

Model/Option	Quantity	Description
B2902A	1	Precision Source/Measure Unit, 2ch, 100 fA, 210 V, 3 A DC/10.5 A pulse
N1294A-001	2	Banana to Triaxial adapter for 2 wire (non-kelvin) connection
16494A	4	Triaxial Cable
16493G	1	Digital I/O connection cable

NOTE

16494A triaxial cable and 16493G Digital I/O cable have several options for cable length. Specify cable option and quantity.

4.5 Agilent B2900A for Characterization of FET & Bipolar Transistor

An SMU combines the capabilities of a current source, a voltage source, a current meter and a voltage meter along with the capability to switch easily between these various functions into a single instrument. This gives it the ability to evaluate the IV characteristics of devices across all four measurement quadrants without the need for any additional equipment. Besides being able to output and measure voltage or current very accurately, SMUs also possess a compliance feature that allows a limit to be placed on the voltage or current output to prevent device damage.

Evaluation of FET or bipolar transistor requires applying different voltages and currents with the constant or the sweep condition to the gate and the drain terminal respectively in order to acquire the several parameters and characteristics.

Table 4-13 Agilent B2902A with N1295A small test fixture (2-wire connections)

Model/Option	Quantity	Description
B2912A	1	Precision Source/Measure Unit, 2ch, 10 fA, 210 V, 3 A DC/10.5 A pulse
N1294A-001	2	Banana to Triaxial adapter for 2 wire (non-kelvin) connection
N1295A	1	Device/component Test Fixture
16494A	4	Triaxial Cable

Table 4-14 Agilent B2902A with 16442B Test Fixture (2-wire connections)

Model/Option	Quantity	Description
B2912A	1	Precision Source/Measure Unit, 2ch, 10 fA, 210 V, 3 A DC/10.5 A pulse
N1294A-001	2	Banana to Triaxial adapter for 2 wire (non-kelvin) connection
16442B	1	Test Fixture for Semiconductor Devices
16494A	4	Triaxial Cable
N1294A-011 (012)	1	Interlock cable for 16442B Test Fixture, 1.5 m (3.0 m)

Table 4-15 Agilent B2902A with 16442B Test Fixture (4-wire connections for 1 channel)

Model/Option	Quantity	Description
B2912A	1	Precision Source/Measure Unit, 2ch, 10 fA, 210 V, 3 A DC/10.5 A pulse
N1294A-001	1	Banana to Triaxial adapter for 2 wire (non-kelvin) connection
N1294A-002	1	Banana to Triaxial adapter for 4 wire (kelvin) connection
16442B	1	Test Fixture for Semiconductor Devices
16494A	5	Triaxial Cable
N1294A-011 (012)	1	Interlock cable for 16442B Test Fixture, 1.5 m (3.0 m)

Table 4-16 Agilent B2912A and accessories for Manual Prober (2-wire connections)

Model/Option	Quantity	Description
B2912A	1	Precision Source/Measure Unit, 2ch, 10 fA, 210 V, 3 A DC/10.5 A pulse
N1294A-001	2	Banana to Triaxial adapter for 2 wire (non-kelvin) connection
16494A	4	Triaxial Cable

Table 4-17 Agilent B2912A and accessories for Manual Prober (4-wire connections)

Model/Option	Quantity	Description
B2912A	1	Precision Source/Measure Unit, 2ch, 10 fA, 210 V, 3 A DC/10.5 A pulse
N1294A-002	2	Banana to Triaxial adapter for 4 wire (non-kelvin) connection
N1254A-107	2	Triax (m) to Triax (f) adapter. (1250-2654)
16494A	6	Triaxial Cable

NOTE 16494A triaxial cable has several options for cable length. Specify cable option and quantity.

4.6 Agilent B2900A for DC Bias to Network Analyzer

The B2900A is the ideal bias source to use with network analyzers for the evaluation of transistor DC and RF characteristics. The B2900A series supports enhanced trigger functions that enable each step of a bias sweep it performs to be synchronized with a frequency sweep performed by a network analyzer.

For details, refer to the Technical Overview, Fast fT-Ic Measurement Using the B2900A series (5990-6895EN).

Table 4-18 Agilent B2902A and accessories for DC Bias to Network Analyzer

Model/Option	Quantity	Description
B2902A	1	Precision Source/Measure Unit, 2ch, 100 fA, 210 V, 3 A DC/10.5 A pulse
1251-2277	2	Adapter-Banana BNC Jack Plug
16493U	2	High current coaxial cable, BNC(m) to BNC(m)
16493G	1	Digital I/O connection cable

NOTE 16493U High current coaxial cable and 16493G Digital I/O cable have several options for cable length. Specify cable option and quantity.

This information is subject to change without notice.
© Keysight Technologies 2011, 2014

